



Husqvarna®

TR 650 Terra/2013
TR 650 Strada/2013

TR 650 Terra



TR 650 Strada



||| Spare parts catalogue Ed. 08/2012 ■■

ATTENZIONE: QUESTO FILE POTREBBE ESSERE OBSOLETO. CONSULTARE SEMPRE LA VERSIONE DEL CATALOGO INTERATTIVO! • WARNING: THIS FILE MAY BE OUT OF DATE. ALWAYS REFER TO THE INTERACTIVE CATALOGUE VERSION! • ATTENTION : CE FICHIER POURRAIT ÊTRE OBSOLÈTE. CONSULTER TOUJOURS LA VERSION DU CATALOGUE INTERACTIF ! • ACHTUNG: DIESE DATEI KÖNNTE VERALTET SEIN. BITTE IMMER DIE VERSION IM INTERAKTIVEN KATALOG NACHSCHLAGEN! • ATENCIÓN: ESTE ARCHIVO PODRÍA SER OBSOLETO. ¡CONSULTAR SIEMPRE LA VERSIÓN DEL CÁTALOGO INTERACTIVO!

TR 650 Terra/2013
TR 650 Strada/2013

INFORMAZIONI GENERALI

Il presente catalogo serve per richiedere con esattezza le parti di ricambio
 Nelle ordinazioni indicare:

- 1) il numero di codice dei particolari seguito dalla descrizione;
 - 2) il colore per i pezzi verniciati o comunque colorati;
 - 3) il numero di matricola del motociclo, stampigliato sul cannotto di sterzo.
- Le indicazioni destra e sinistra si riferiscono ai lati del veicolo rispetto al senso di marcia.

GENERAL INFORMATION

The present spare parts list enables one to order exactly the right spare parts.

When ordering specify:

- 1) the part's code number followed by its description;
 - 2) indicate colour for painted or coloured parts;
 - 3) the motorcycle's serial number, stamped on the steering head.
- References to right and left apply to the vehicle in terms of its direction of movement.

INFORMATIONS GENERALES

Ca catalogue permet de commander correctement les pièces de rechange.

Les commandes doivent être passées en indiquant:

- 1) le numéro de code des pièces détachées suivi de leur description;
 - 2) le couleur des pièces peintes ou colorés;
 - 3) le matricule de la moto, estampillé sur la tige du guidon.
- Droite et gauche sont les côtés du véhicule par rapport au sens de la marche.

ALLGEMEINE HINWEISE

Dieser Ersatzteilkatalog dient zur genauen Angabe der Teile bei Ersatzteilbestellungen.

Bei Ersatzbestellung ist folgendes anzugeben:

- 1) Die Bestellnummer der Ersatzteile mit der entsprechenden Beschreibung;
 - 2) Farbe für lackierte und farbige Teile angeben;
 - 3) Die Sseriennummer des Motorrads, die am Lenkrohr eingeprägt ist.
- Die Angaben rechts und links beziehen sich auf das Fahrzeug in Fahrrichtung.

INFORMACIONES GENERALES

El presente catálogo sirve para pedir con exactitud las partes de recambio.

En los pedidos se debe indicar:

- 1) el número de código de la parte y a continuación la descripción;
 - 2) el color para las piezas barnizadas o coloreadas;
 - 3) el número de matrícula de la motocicleta, estampado en le tubo de dirección.
- Las indicaciones derecha e izquierda se refieren a los lados del vehículo respecto del sentido de marcha.

NOTE - LIST - NOTES - NOTE - NOTAS:

- A : Austria, Austria, Autriche, Österreich, Austria
- AUS : Australia, Australia, Australie, Australien, Australia
- B : Belgio, Belgium, Belgique, Belgien, Bélgica
- BR : Brasile, Brazil, Brasile, Brasilien, Brasil
- CDN : Canada, Canada, Canada, Kanada, Canadá
- CH : Svizzera, Switzerland, Suisse, Schweizer, Suiza
- D : Germania, Germany, Allemagne, Deutschland, Alemania
- E : Spagna, Spain, Espagne, Spanien, España
- F : Francia, France, France, Frankreich, Francia
- GB : Gran Bretagna, Great Britain, Grand Bretagne, Groos Britan, Gran Bretaña
- I : Italia, Italy, Italie, Italien, Italia
- J : Giappone, Japan, Japon, Japan, Japón
- SF : Finlandia, Finald, Finlande, Finnland, Finlandia
- USA : Stati Uniti d'America, United States of America, Etats Units d'Amerique, Vereinigte Staaten von Amerika, Estados Unidos
- RUS : Russia, Russia, Russie, Rußland, Rusia

N° DI MATRICOLA INIZIALE - INITIAL SERIAL NUMBER - MATRICULE INITIAL - BEGINNTESEIENNUMMER - MATRICULA INICIAL	
MODELLO - MODEL MODELE - MODELL MODELO	MATRICOLA - SERIAL NUMBER MATRICULE - SERIENNUMMER MATRICULA
TR 650 Terra (43 kW)	ZKH0H11A#DV000001
TR 650 Terra (43 kW - ABS)	ZKH0H11C#DV000001
TR 650 Terra (35 kW - ABS)	ZKH0H11D#DV000001
TR 650 Strada (43 kW - ABS)	ZKH0H11E#DV000001
TR 650 Strada (35 kW - ABS)	ZKH0H11F#DV000001

Tavola Drawing Table Bild Tabla	Denominazione	Description	Designation	Bezeichnung	Denominacion	Pagina Page Page Seite Paja
1	DOTAZIONE MOTOCICLO	MOTORCYCLE EQUIPMENT	EQUIPEMENT MOTO	MOTORRAD AUSRUSTUNG	MOTOCICLETA INCLUIDO	15
2	CARTER	CRANKCASE	CARTER	GEHAUSE	BANCADA	17
3	CARTER	CRANKCASE	CARTER	GEHAUSE	BANCADA	19
4	MOTORE	ENGINE	MOTEUR	MOTOR	MOTOR	21
5	TESTA CILINDRO	CYLINDER HEAD	CULASSE CYLINDRE	ZYLINDERKOPF	CULATA	23
6	COPERCHIO VALVOLE	VALVE COVER	COUVERCLE	VENTILDECKEL	TAPA VALVULE	25
7	COPERCHIO FRIZIONE	CLUTCH COVER	COUVERCLE D'EMBARAYAGE	KUPPLUNGSDECKEL	TAPA EMBRAGUE	27
8	COPERCHI BASAMENTO	CRANKCASE COVERS	COUVERCLES CARTER	GEHAUSEDECKEL	TAPA BANCADA	29
9	MANOVELLISMO	CRANKSHAFT	VILEBREQUIN	KURBELWELLE	CIGUENAL	31
10	PISTONE	PISTON	PISTON	KOLBEN	PISTON	33
11	ALBERO DI COMPENSAZIONE	BALANCE SHAFT	ARBRE DE COMPENSATION	COMPENSATIONSWELLE	EJE DE COMPENSACION	35
12	DISTRIBUZIONE	VALVE TIMING	DISTRIBUTION	VENTILSTEUERUNG	DISTRIBUCION	37
13	VALVOLE	VALVES	SOUPAPES	VENTILE	VALVULAS	39
14	POMPA OLIO	OIL PUMP	POMPE A HUILE	ÖLPUMPE	BOMBA ACEITE	41
15	FILTRO OLIO	OIL FILTER	FILTRE A HUILE	ÖLFILTER	FILTRO ACEITE	43
16	CORPO FARFALLATO	THROTTLE BODY	CORP PAPILLON	DROSSELKLAPPENKORPER	CUERPO OSCILANTE	45
17	POMPA ACQUA	WATER PUMP	POMPE A EAU	WASSERPUMPE	BOMBA DE AGUA	47
18	AVVIAMENTO ELETTRICO	ELECTRIC STARTER	DEMARREUR ELECRTIQUE	ELEKTRISCHEANLASSAR	ARRANQUE ELECTRICO	49
19	PARTE ELETTRICA MOTORE	ENGINE ELECTRIC PART	PARTIES ELECTRIQUE MOTEUR	ELEKTRISCHE ANLAGE	PARTE ELECTRICA MOTOR	51
20	ALBERO FRIZIONE	CLUTCH SHAFT	LEVIER EMBRAYAGUE	KUPPLUNGSHBEL	PALANCA EMBRAGUE	53
21	COMANDO CAMBIO	GEAR SHIFT	COMMANDE DE VITESSE	SCHALTUNG	MANDO CAMBIO	55
22	FRIZIONE	CLUTCH	EMBRAYAGE	KUPPLUNG	EMBRAGUE	57
23	CAMBIO	GEARBOX	BOITE DE VITESSE	WECHSELGETRIBE	CAMBIO	59
24	CIRCUITO OLIO	OIL SYSTEM	SYSTEME D'HUILE	ÖLSYSTEM	SISTEMA DE ACEITE	61
25	IMPIANTO DI RAFFREDDAMENTO	COOLING SYSTEM	INSTALLATION REFROIDISSEMENT	SCHMIERUNGSSYSTEM	EQUIPO DE ENFRIAMIENTO	63
26	CASSA FILTRO ARIA	AIR BOX	BOITE FILTRE	FILTERKASTEN	CAJA FILTRO DE AIRE	65
27	SERBATOIO CARBURANTE	FUEL TANK	RESERVOIR CARBURANT	KRAFTSTOFFBEHALTER	DEPOSITO GASOLINA	67
28	TELAIO 1/2	FRAME 1/2	CADRE 1/2	RAHMEN 1/2	BASTIDOR 1/2	69
29	TELAIO 2/2	FRAME 2/2	CADRE 2/2	RAHMEN 2/2	BASTIDOR 2/2	73
30	PANNELLI, PARAFANGHI ANTERIORI	FRONT PANELS, FENDERS	PANNEAU, GARDE-BOUES AVANT	STREIFEN, KOTFLUGEL VORDER	PANELES, GUARDABARROS DELANTERO	75
31	PANNELLI, PARAFANGHI POSTERIORI	REAR PANELS, FENDERS	PANNEAU, GARDE-BOUES ARRIERE	STREIFEN, KOTFLUGEL HINTEN	PANELES, GUARDABARROS TRASERO	77
32	MANUBRIO	HANDLEBAR	GUIDON	LENKER	MANILLAR	79
33	FORCELLA	FORK	FOURCHE	GABEL	HORQUILLA	81

Tavola Drawing Table Bild Tabla	Denominazione	Description	Designation	Bezeichnung	Denominacion	Pagina Page Seite Paja
33A	SOSPENSIONE ANTERIORE	FRONT FORK ASSEMBLY	SUSPENSION AVANT	VORDERTELESKOPGABEL	SUSPENSION DELANTERA	83
34	AMMORTIZZATORE POSTERIORE	REAR SHOCK ABSORBER	AMMORTISSEUR ARRIÈRE	HINTERSTOSSDAMPFER	AMORTIGUADOR TRASERO	85
35	LEVERAGGI SOSPEN. POSTERIORE	REAR SUSPENSION LINKAGE	LEVIER SUSPENSION ARRIERE	HEBELWERK HINTERHAUFHANGUNG	PALANCA SUSPENSION TRASERA	87
36	FORCELLONE POSTERIORE	REAR SWING ARM	FOURCHE ARRIERE	HINTERGABEL	HORQUILLA TRASERA	89
37	SCARICO	EXHAUST SYSTEM	TUYAU D'ECHAPPEMENT	AUSPUFFROHR	TUBO DE ESCAPE	91
38	FRENO IDRAULICO ANTERIORE	FRONT HYDRAULIC BRAKE	FREIN HYDRAULIQUE AVANT	VORDERBREMSE	FRENO HIDRAULICO DELANTERO	93
39	FRENO IDRAULICO POSTERIORE	REAR HYDRAULIC BRAKE	FREIN HYDRAULIQUE ARRIERE	HINTERBREMSE	FRENO HIDRAULICO TRASERO	95
40	RUOTA ANTERIORE (Strada)	FRONT WHEEL (Strada)	ROUE AVANT (Strada)	VORTERRAD (Strada)	RUEDA DELANTERA (Strada)	97
41	RUOTA ANTERIORE (Terra)	FRONT WHEEL (Terra)	ROUE AVANT (Terra)	VORTERRAD (Terra)	RUEDA DELANTERA (Terra)	99
42	RUOTA POSTERIORE (Strada)	REAR WHELL (Strada)	ROUE ARRIERE (Strada)	HINTERRAD (Strada)	RUEDA TRASERA (Strada)	101
43	RUOTA POSTERIORE (Terra)	REAR WHELL (Terra)	ROUE ARRIERE (Terra)	HINTERRAD (Terra)	RUEDA TRASERA (Terra)	103
44	GRUPPO CAVI, PARTI ELETTRICHE	MAIN WIRING, ELECTRICAL PARTS	CABLES PRINCIPAL, PARTIES ELECTRIQUES	KABEL, ELEKTISCHE KOMPONENTE	GRUPO PRINCIPAL CABLES, PARTES ELECTRICAS	105
45	IMPIANTO ELETTRICO, STRUMENTO, FANALERIA	ELECRTC SYSTEM, DIGITAL INSTRUMENT	PARTES ELECTIQUE, INSTRUMENT DIGITAL	ELEKTISCHE KOMPONENTE, TACHOMETER	PARTES ELECTRICAS, INSTRUMENTO DIGITAL	109
46	IMPIANTO ABS	ABS SYSTEM	INSTALLATION ABS	SYSTEM ABS	EQUIPO ABS	111
47	KIT CANISTER	CANISTER KIT	KIT CANISTER	CANISTER KIT	KIT CANISTER	113
48	KIT SERRATURE	LOCK KIT	KIT SERRURE	SATZ SCHLOSSER	KIT CERRADURAS	115
49	DECALCOMANIE (Terra)	TRANSFERS (Terra)	DECALCOMANIE (Terra)	ABZIEHBILD (Terra)	CALCOMANIA (Terra)	117
50	DECALCOMANIE (Strada)	TRANSFERS (Strada)	DECALCOMANIE (Strada)	ABZIEHBILD (Strada)	CALCOMANIA (Strada)	119
51	ATTREZZI OFFICINA	WORKSHOP TOOLS	EQUIPEMENT DES ATELIERS	SPEZIALWERKZEUG	HERRAMIENTAS DE TALLER	121

Tavola - Drawing - Table - Bild - Tabla

1

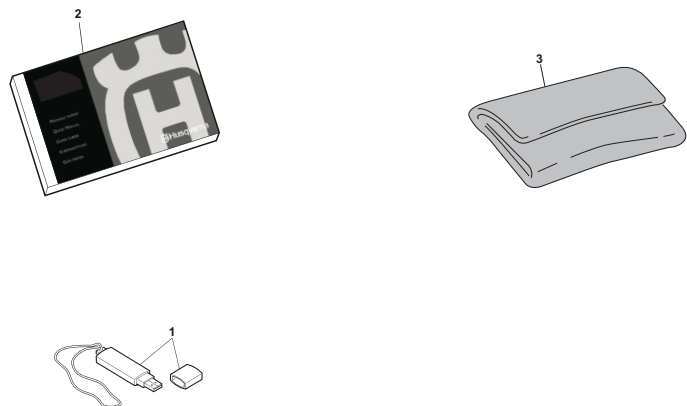

Pagina - Page - Page - Seite - Paja

14

Tavola - Drawing - Table - Bild - Tabla

2

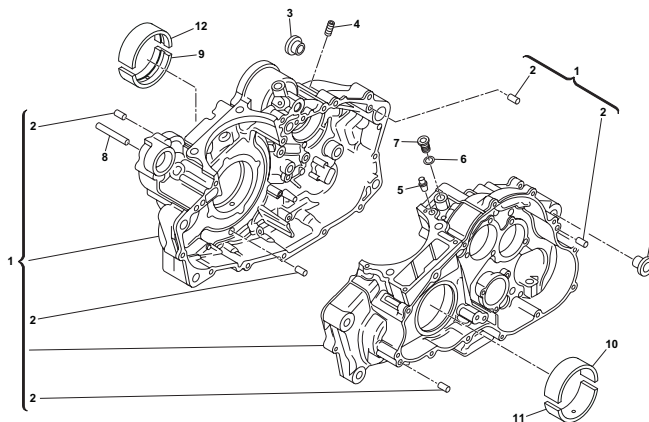

Pagina - Page - Page - Seite - Paja

16

Tavola - Drawing - Table - Bild - Tabla

3

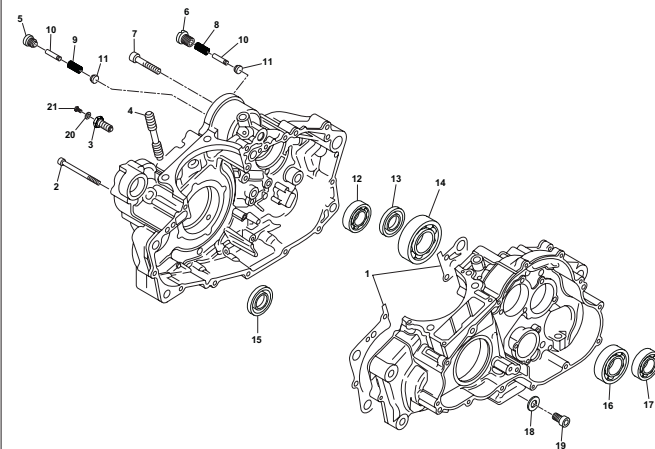

Pagina - Page - Page - Seite - Paja

18

Tavola - Drawing - Table - Bild - Tabla

4

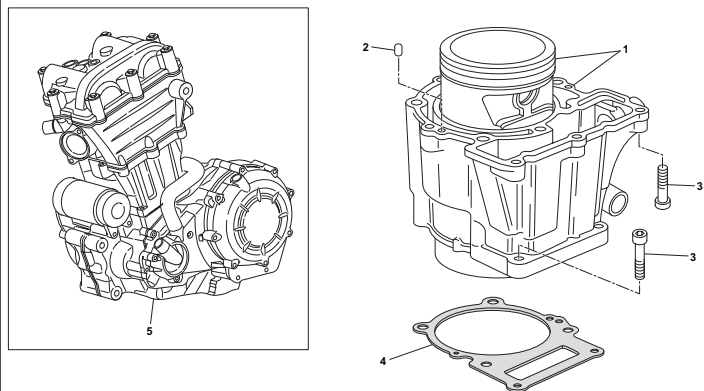

Pagina - Page - Page - Seite - Paja

20

Tavola - Drawing - Table - Bild - Tabla

5

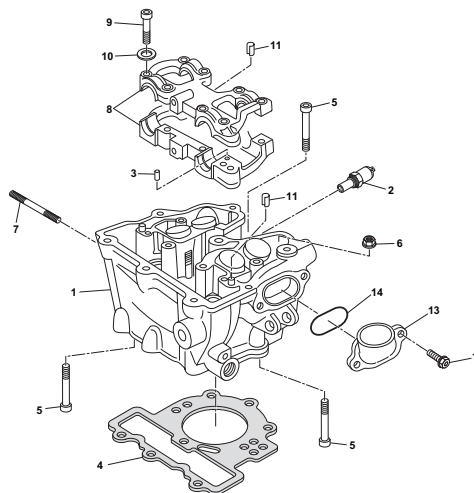

Pagina - Page - Page - Seite - Paja

22

Tavola - Drawing - Table - Bild - Tabla

6

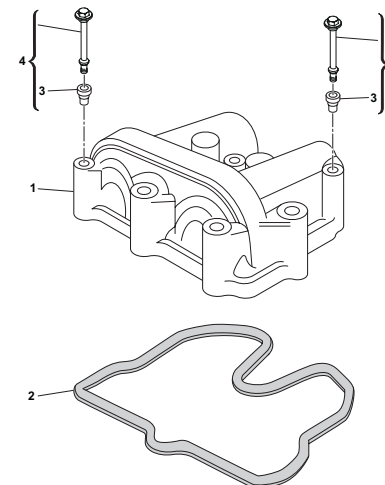

Pagina - Page - Page - Seite - Paja

24

Tavola - Drawing - Table - Bild - Tabla

7

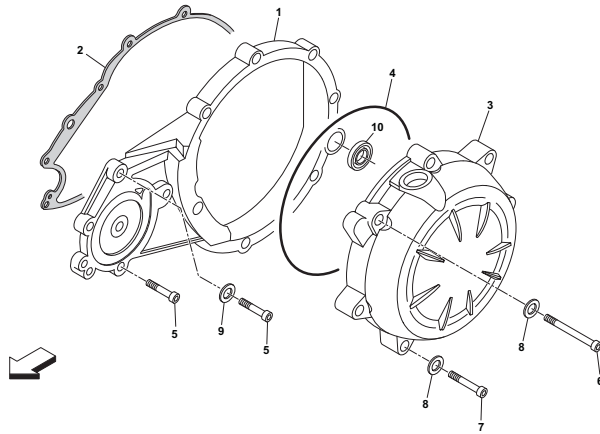

Pagina - Page - Page - Seite - Paja

26

Tavola - Drawing - Table - Bild - Tabla

8

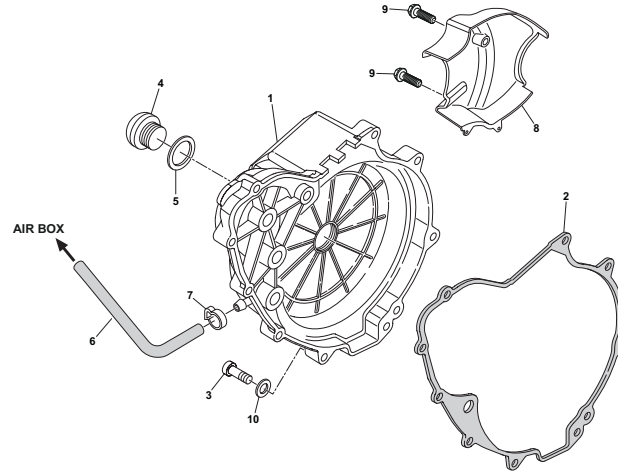

Pagina - Page - Page - Seite - Paja

28

Tavola - Drawing - Table - Bild - Tabla

9

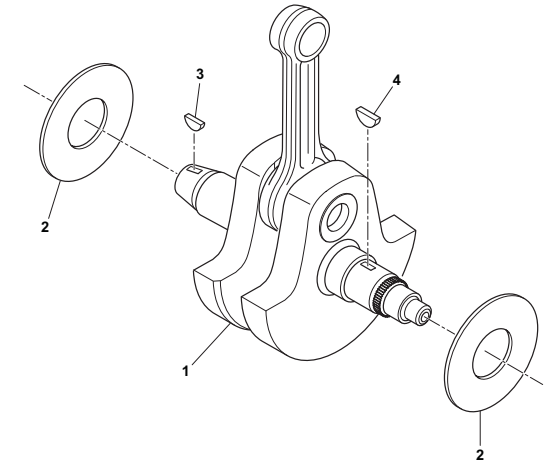

Pagina - Page - Page - Seite - Paja

30

Tavola - Drawing - Table - Bild - Tabla

10

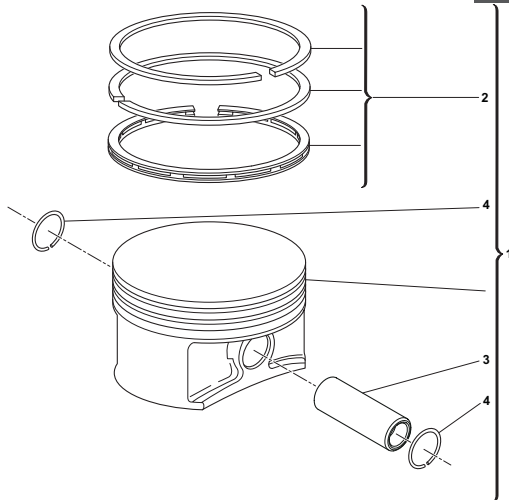

Pagina - Page - Page - Seite - Paja

32

Tavola - Drawing - Table - Bild - Tabla

11

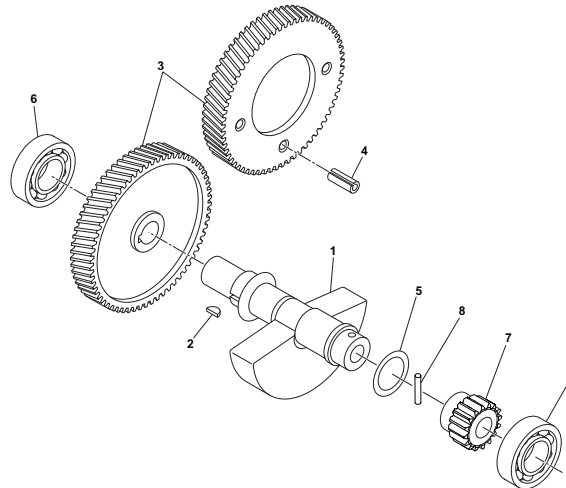

Pagina - Page - Page - Seite - Paja

34

Tavola - Drawing - Table - Bild - Tabla

12

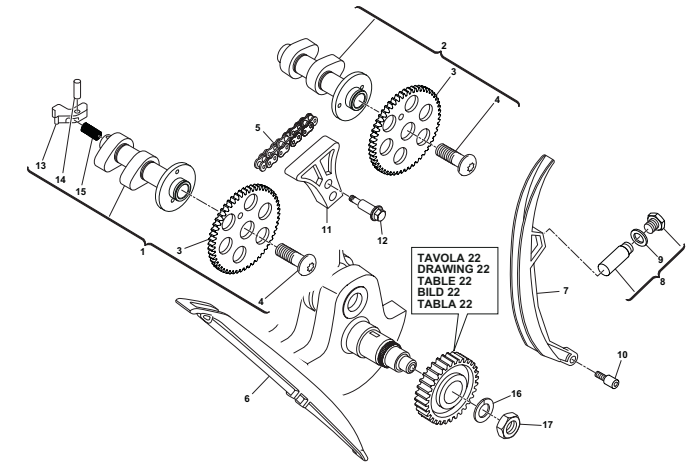

Pagina - Page - Page - Seite - Paja

36

Tavola - Drawing - Table - Bild - Tabla

13

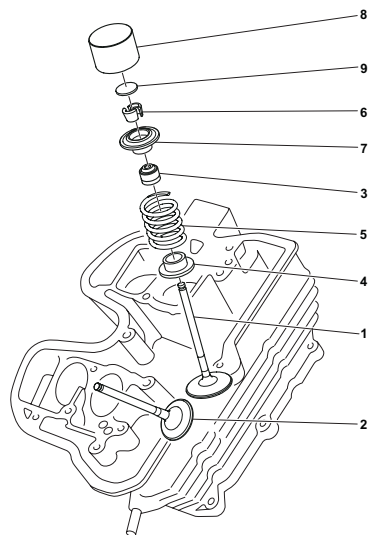

Pagina - Page - Page - Seite - Paja

38

Tavola - Drawing - Table - Bild - Tabla

14

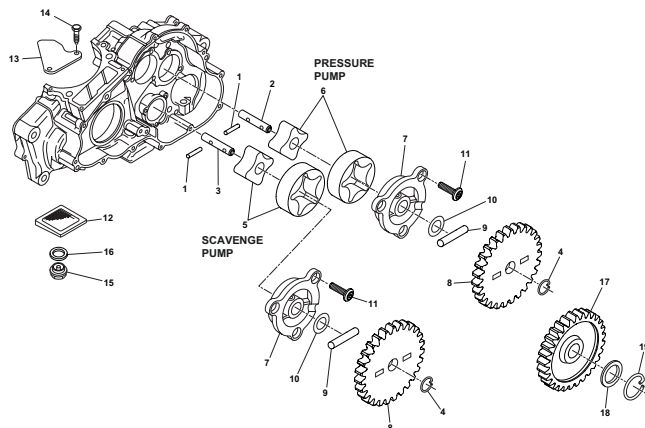

Pagina - Page - Page - Seite - Paja

40

Tavola - Drawing - Table - Bild - Tabla

15

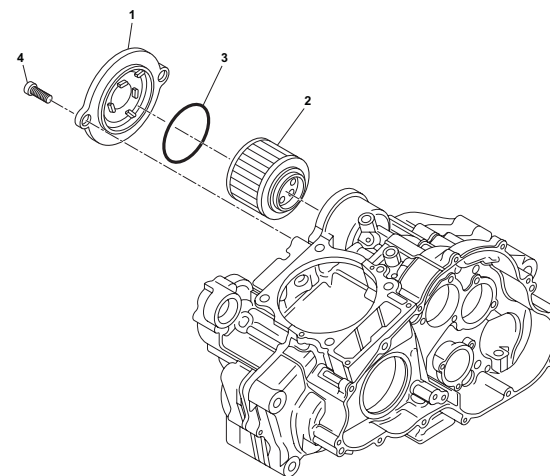

Pagina - Page - Page - Seite - Paja

42

Tavola - Drawing - Table - Bild - Tabla

16

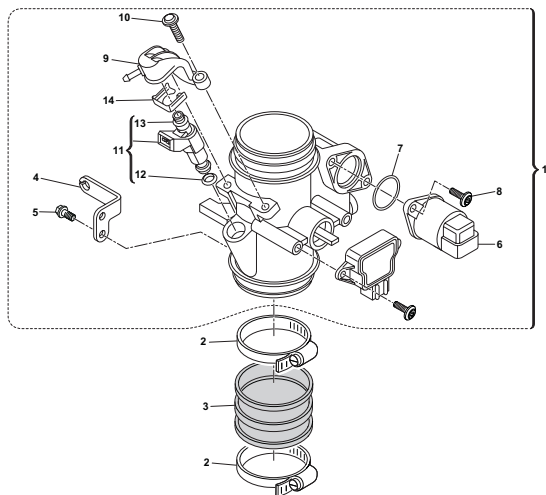

Pagina - Page - Page - Seite - Paja

44

Tavola - Drawing - Table - Bild - Tabla

17

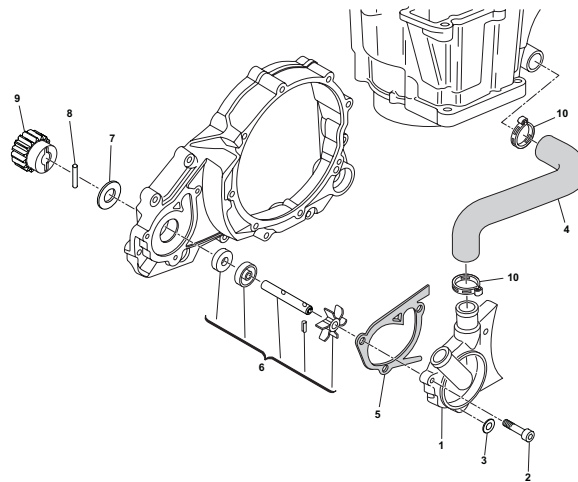

Pagina - Page - Page - Seite - Paja

46

Tavola - Drawing - Table - Bild - Tabla

18

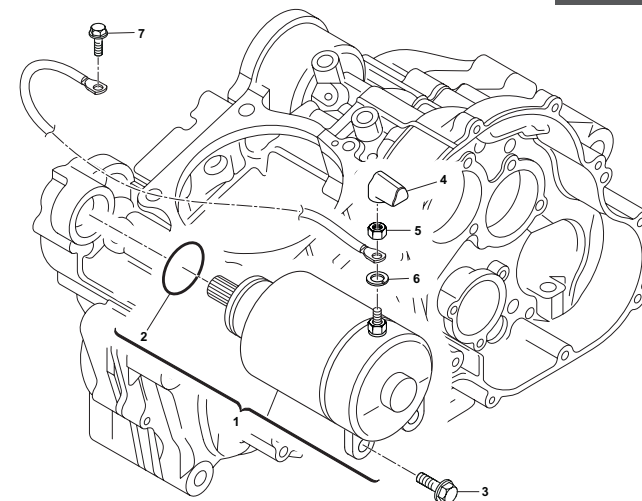

Pagina - Page - Page - Seite - Paja

48

Tavola - Drawing - Table - Bild - Tabla

19

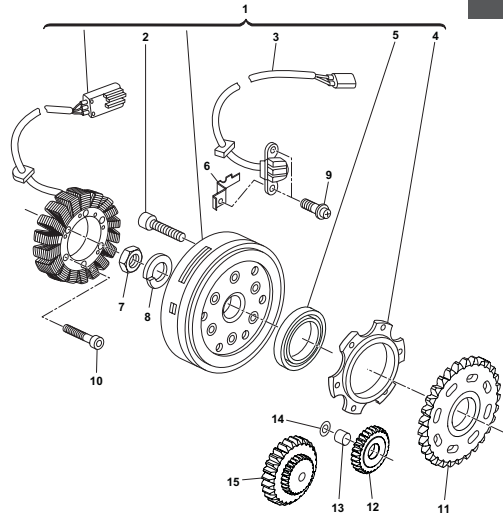

Pagina - Page - Page - Seite - Paja

50

Tavola - Drawing - Table - Bild - Tabla

20

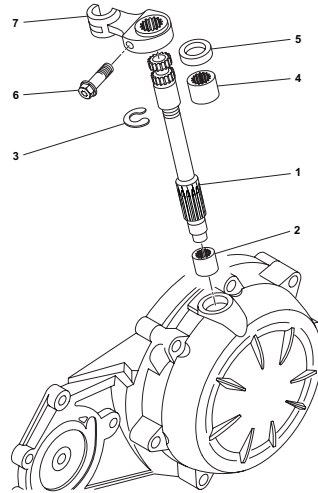

Pagina - Page - Page - Seite - Paja

52

Tavola - Drawing - Table - Bild - Tabla

21

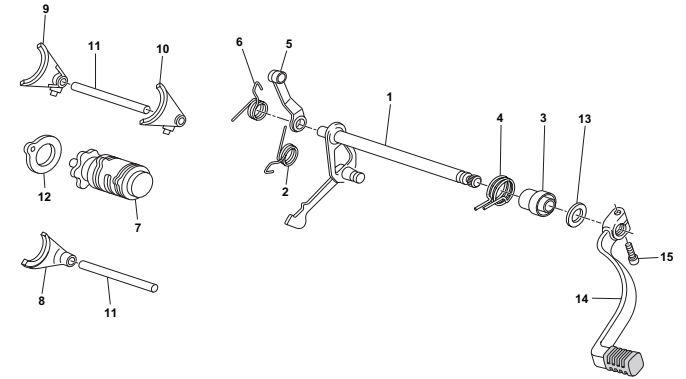

Pagina - Page - Page - Seite - Paja

54

Tavola - Drawing - Table - Bild - Tabla

22

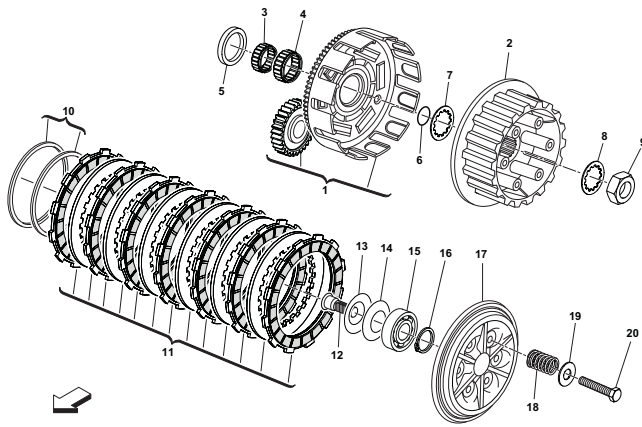

Pagina - Page - Page - Seite - Paja

56

Tavola - Drawing - Table - Bild - Tabla

23

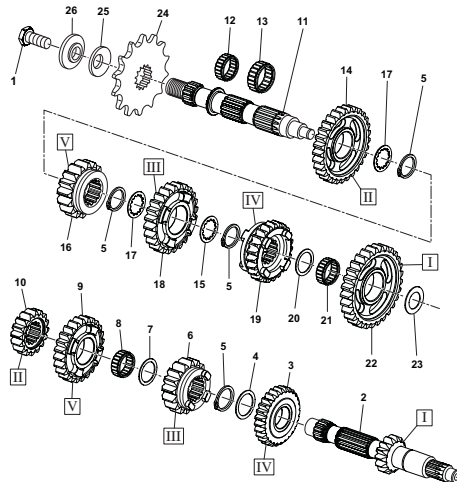

Pagina - Page - Page - Seite - Paja

58

Tavola - Drawing - Table - Bild - Tabla

24

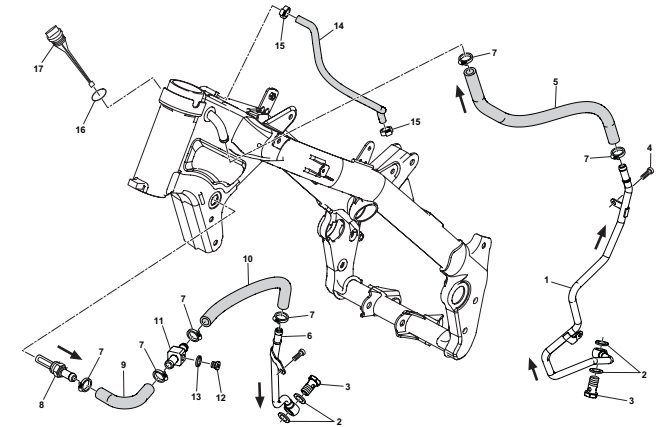

Pagina - Page - Page - Seite - Paja

60

Tavola - Drawing - Table - Bild - Tabla

25

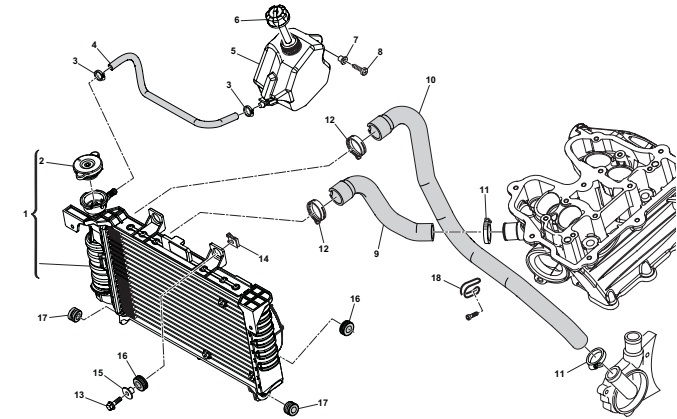

Pagina - Page - Page - Seite - Paja

62

Tavola - Drawing - Table - Bild - Tabla

26

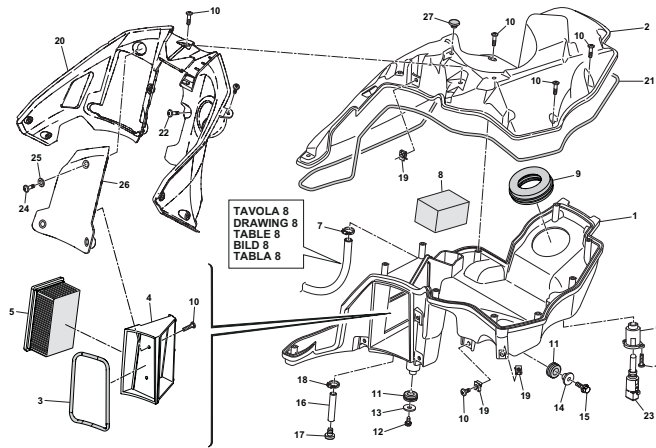

Pagina - Page - Page - Seite - Paja

64

Tavola - Drawing - Table - Bild - Tabla

27

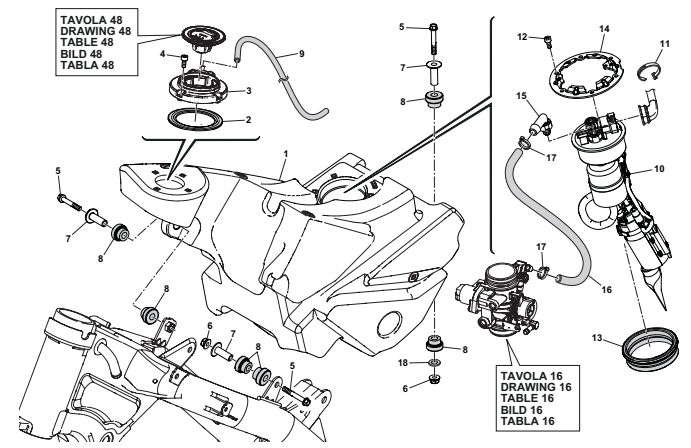

Pagina - Page - Page - Seite - Paja

66

Tavola - Drawing - Table - Bild - Tabla

28

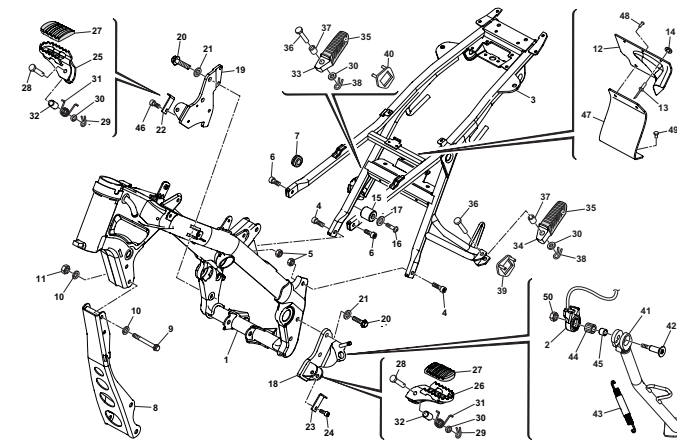

Pagina - Page - Page - Seite - Paja

68

Tavola - Drawing - Table - Bild - Tabla

29

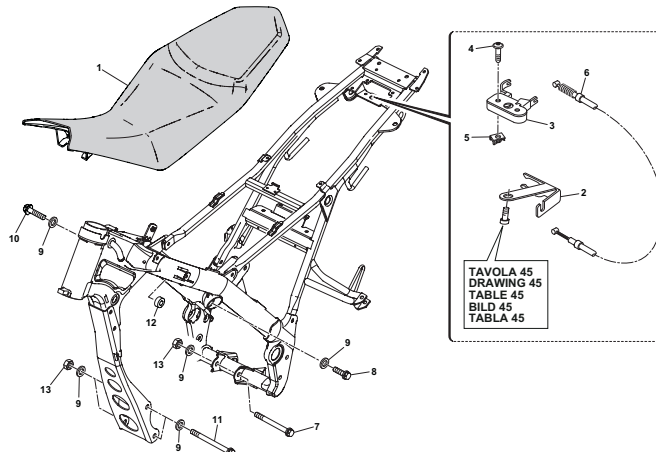

Pagina - Page - Page - Seite - Paja

72

Tavola - Drawing - Table - Bild - Tabla

30

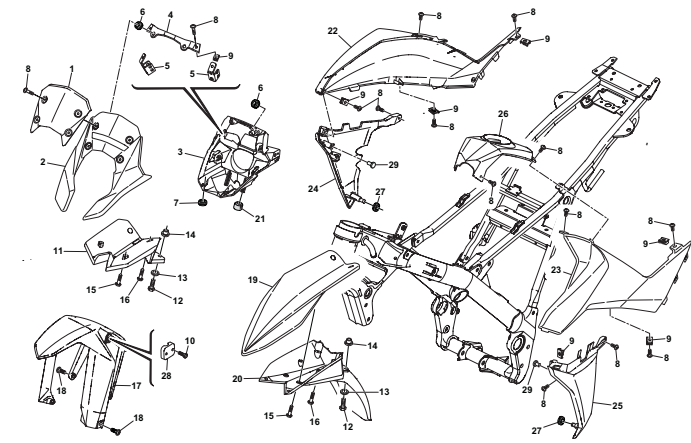

Pagina - Page - Page - Seite - Paja

74

Tavola - Drawing - Table - Bild - Tabla

31

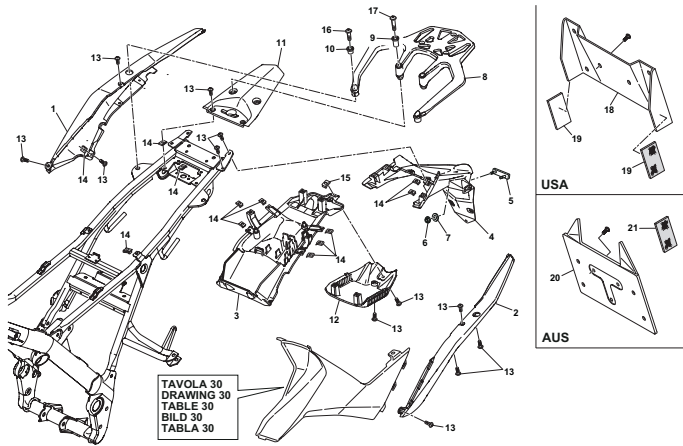

Pagina - Page - Page - Seite - Paja

76

Tavola - Drawing - Table - Bild - Tabla

32

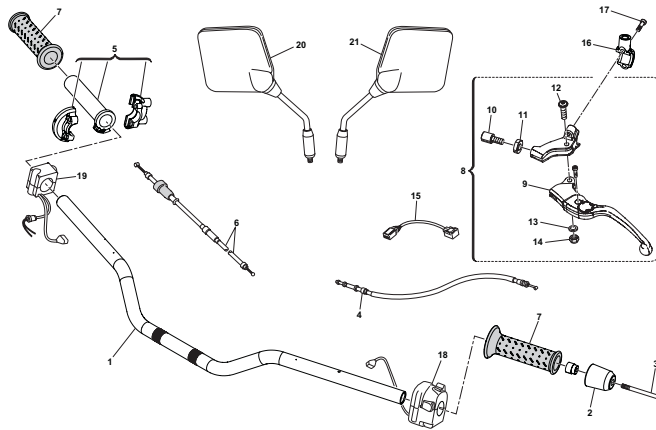

Pagina - Page - Page - Seite - Paja

78

Tavola - Drawing - Table - Bild - Tabla

33

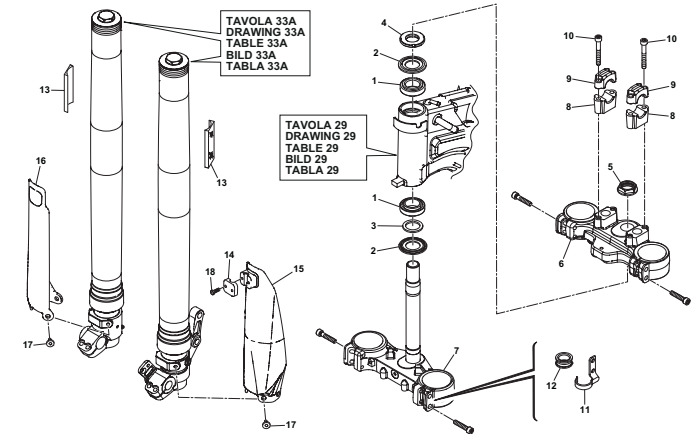

Pagina - Page - Page - Seite - Paja

80

Tavola - Drawing - Table - Bild - Tabla

33A

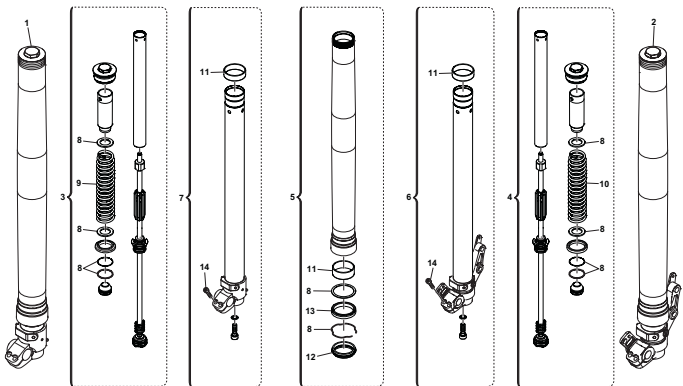

Pagina - Page - Page - Seite - Paja

82

Tavola - Drawing - Table - Bild - Tabla

34

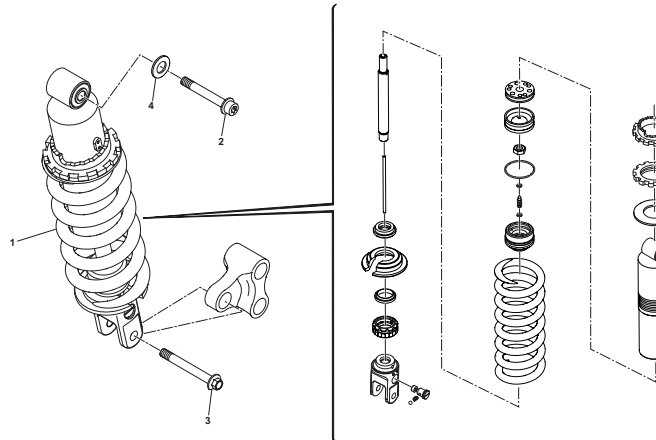

Pagina - Page - Page - Seite - Paja

84

Tavola - Drawing - Table - Bild - Tabla

35

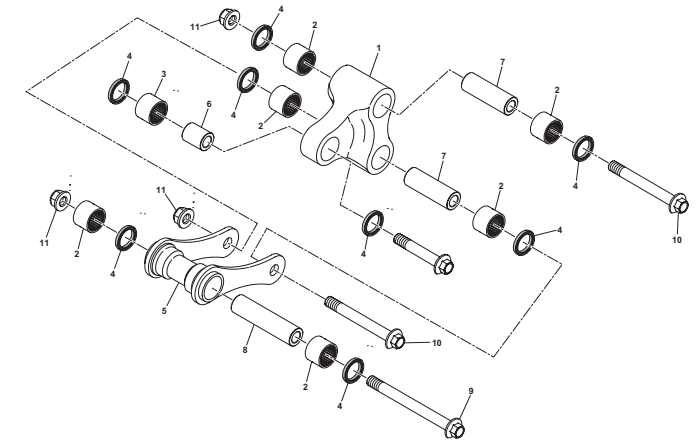

Pagina - Page - Page - Seite - Paja

86

Tavola - Drawing - Table - Bild - Tabla

36

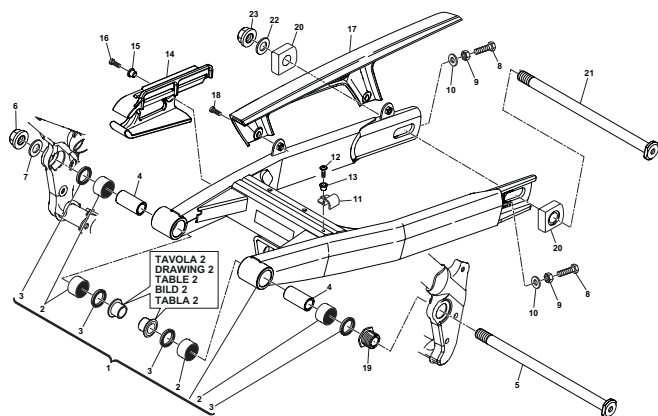

Pagina - Page - Page - Seite - Paja

88

Tavola - Drawing - Table - Bild - Tabla

37

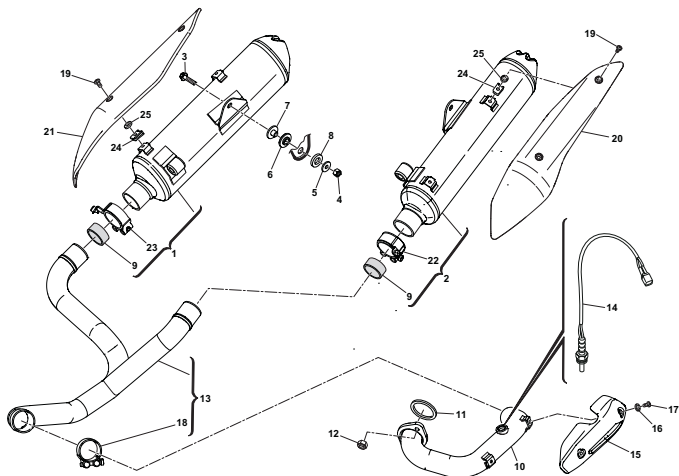

Pagina - Page - Page - Seite - Paja

90

Tavola - Drawing - Table - Bild - Tabla

38

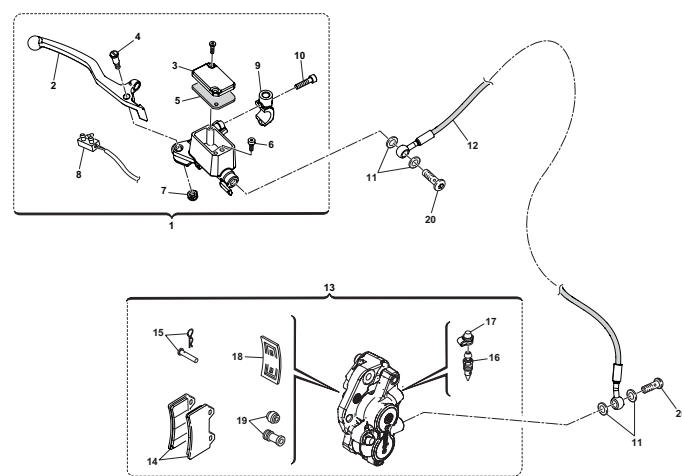

Pagina - Page - Page - Seite - Paja

92

Tavola - Drawing - Table - Bild - Tabla

39

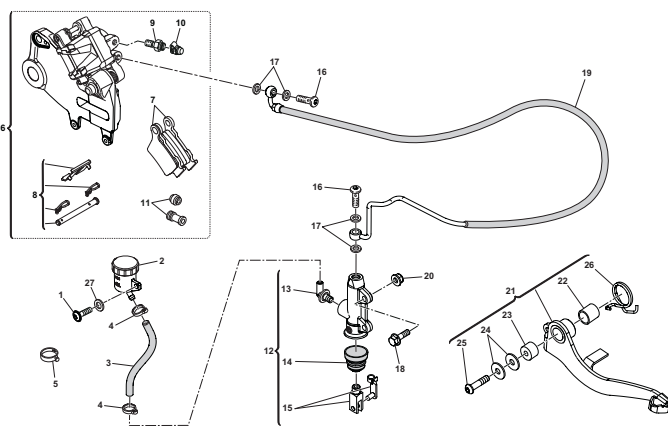

Pagina - Page - Page - Seite - Paja

94

Tavola - Drawing - Table - Bild - Tabla

40

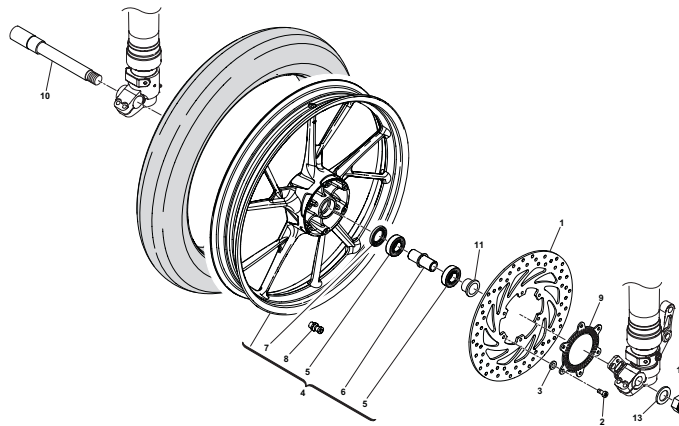

Pagina - Page - Page - Seite - Paja

96

Tavola - Drawing - Table - Bild - Tabla

41

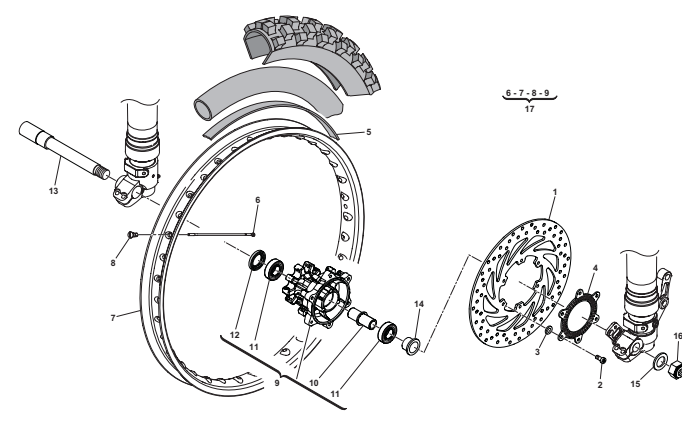

Pagina - Page - Page - Seite - Paja

98

Tavola - Drawing - Table - Bild - Tabla

42

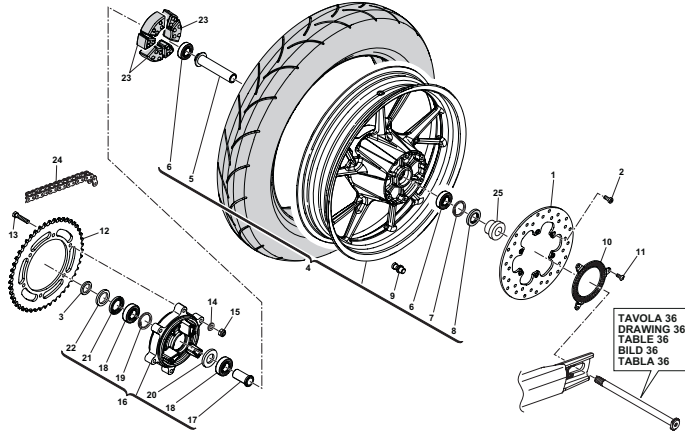

Pagina - Page - Page - Seite - Paja

100

Tavola - Drawing - Table - Bild - Tabla

43

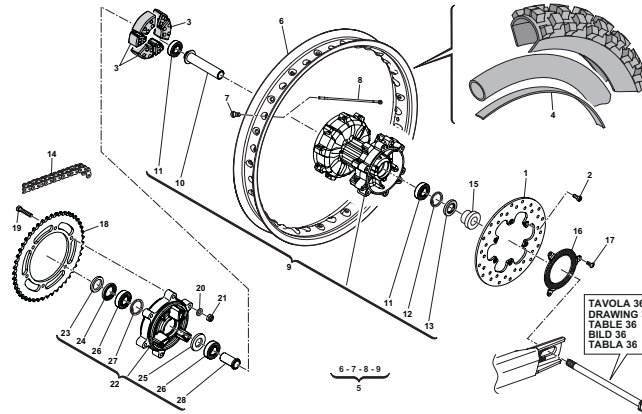

Pagina - Page - Page - Seite - Paja

102

Tavola - Drawing - Table - Bild - Tabla

44

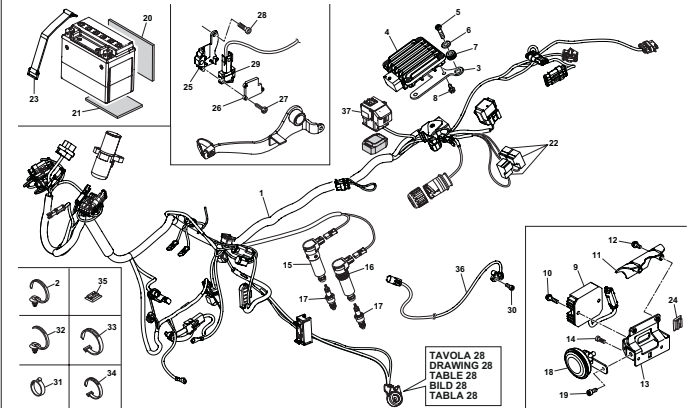

Pagina - Page - Page - Seite - Paja

104

Tavola - Drawing - Table - Bild - Tabla

45

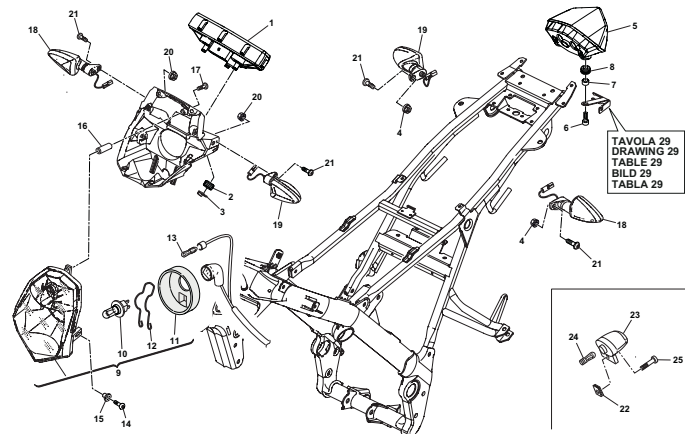

Pagina - Page - Page - Seite - Paja

108

Tavola - Drawing - Table - Bild - Tabla

46

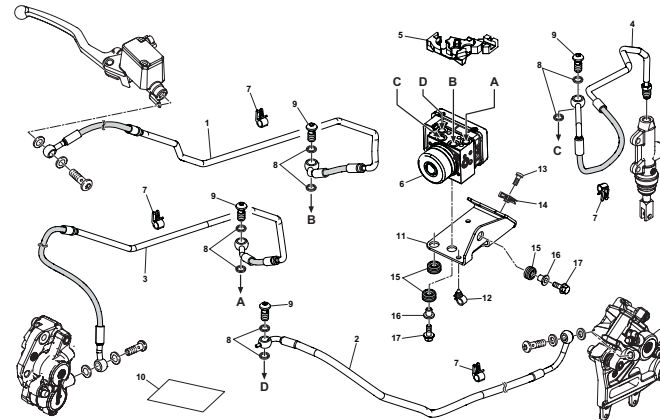

Pagina - Page - Page - Seite - Paja

110

Tavola - Drawing - Table - Bild - Tabla

47

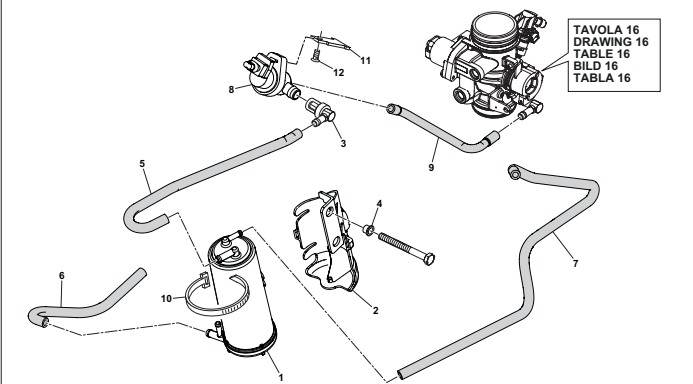

Pagina - Page - Page - Seite - Paja

112

Tavola - Drawing - Table - Bild - Tabla

48

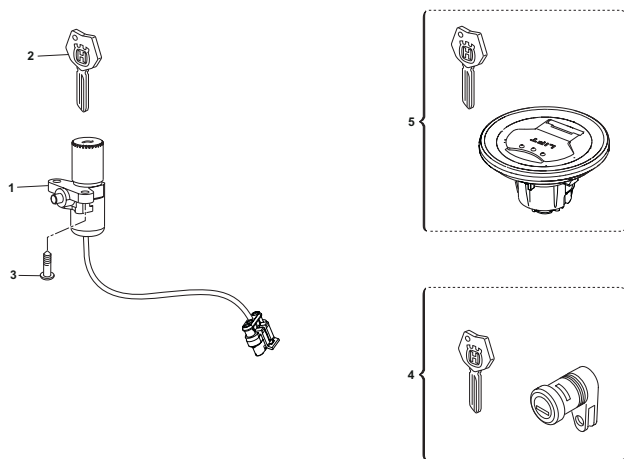

Pagina - Page - Page - Seite - Paja

114

Tavola - Drawing - Table - Bild - Tabla

49

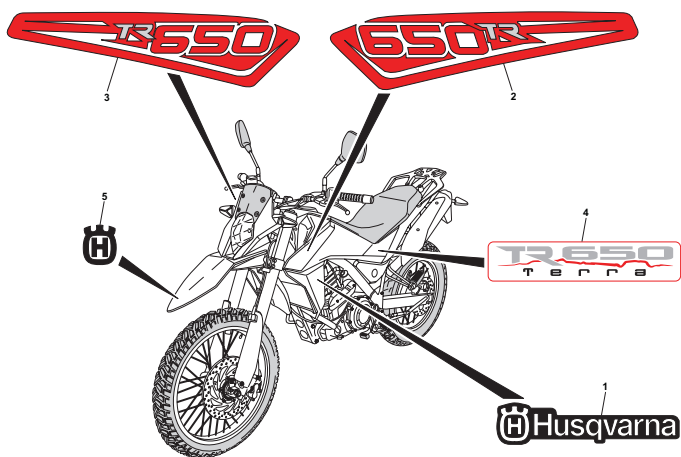

Pagina - Page - Page - Seite - Paja

116

Tavola - Drawing - Table - Bild - Tabla

50

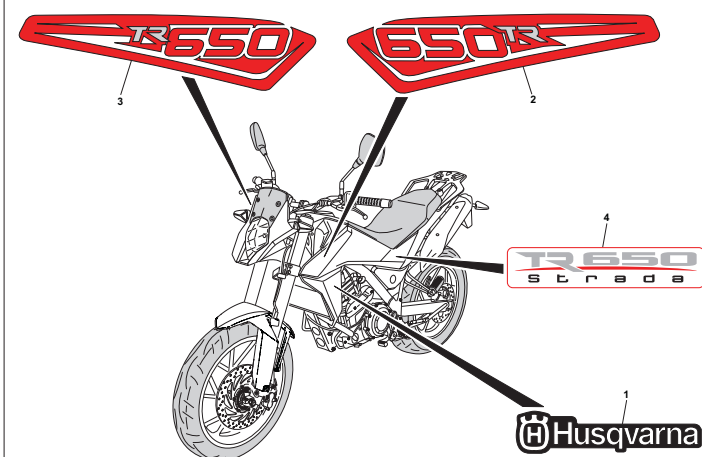

Pagina - Page - Page - Seite - Paja

118

Tavola - Drawing - Table - Bild - Tabla

51

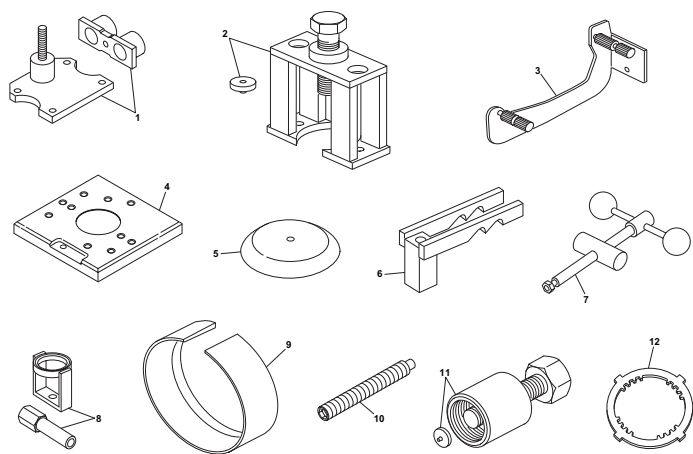

Pagina - Page - Page - Seite - Paja

120

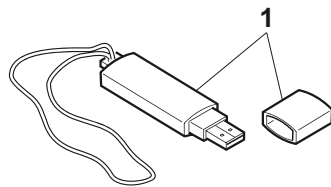
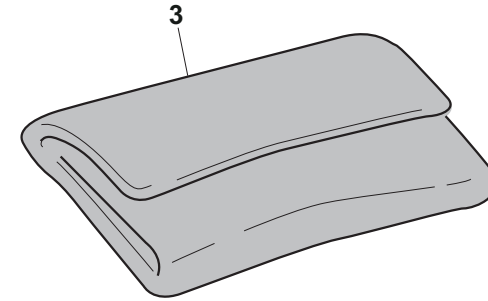
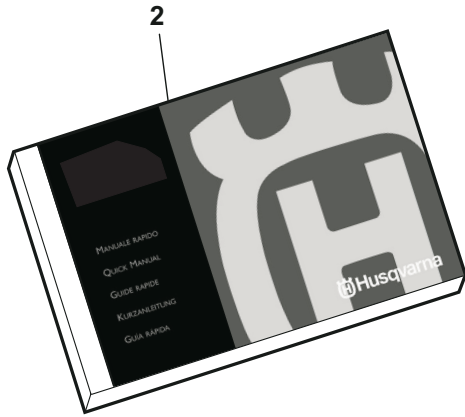

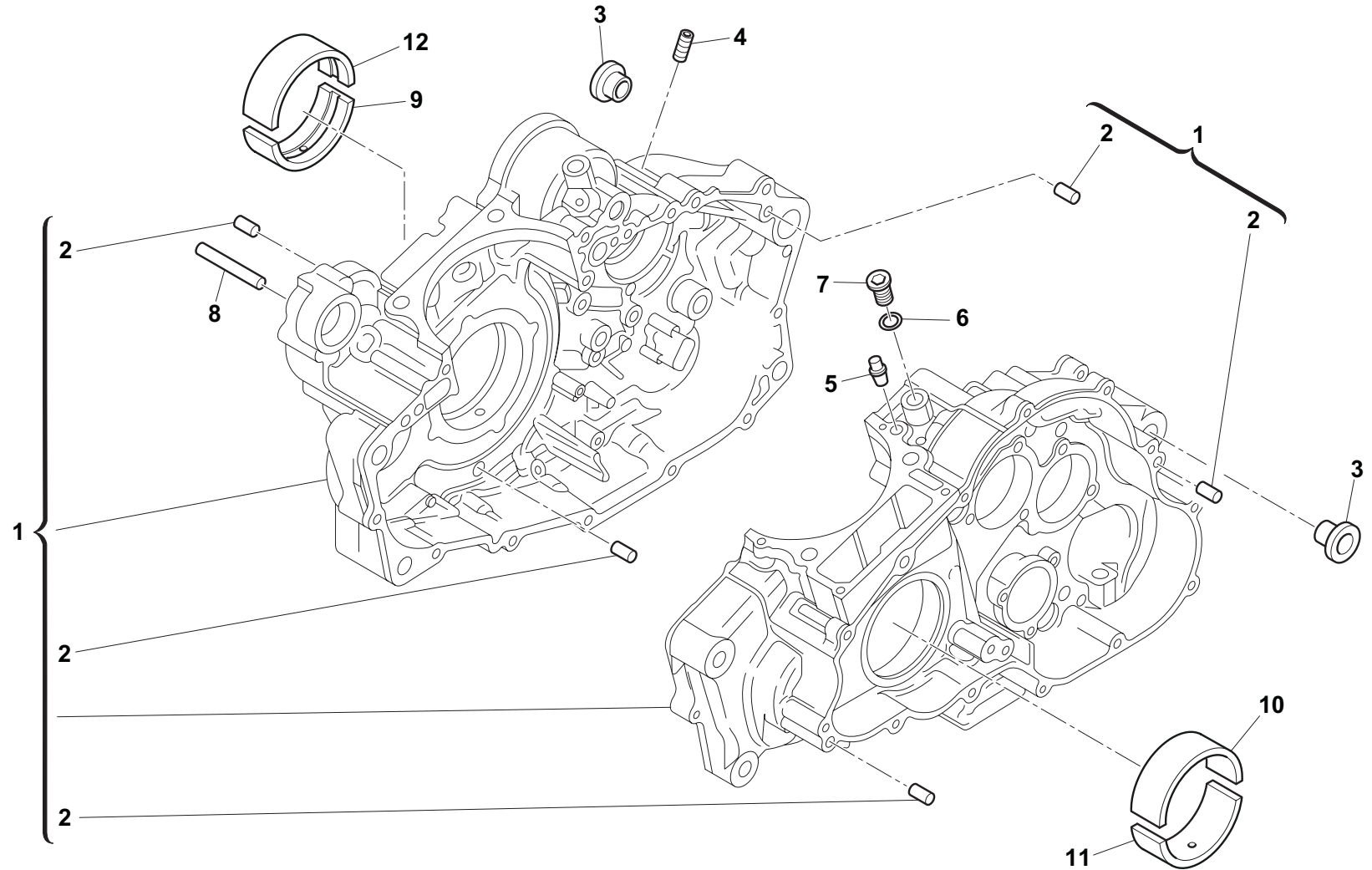

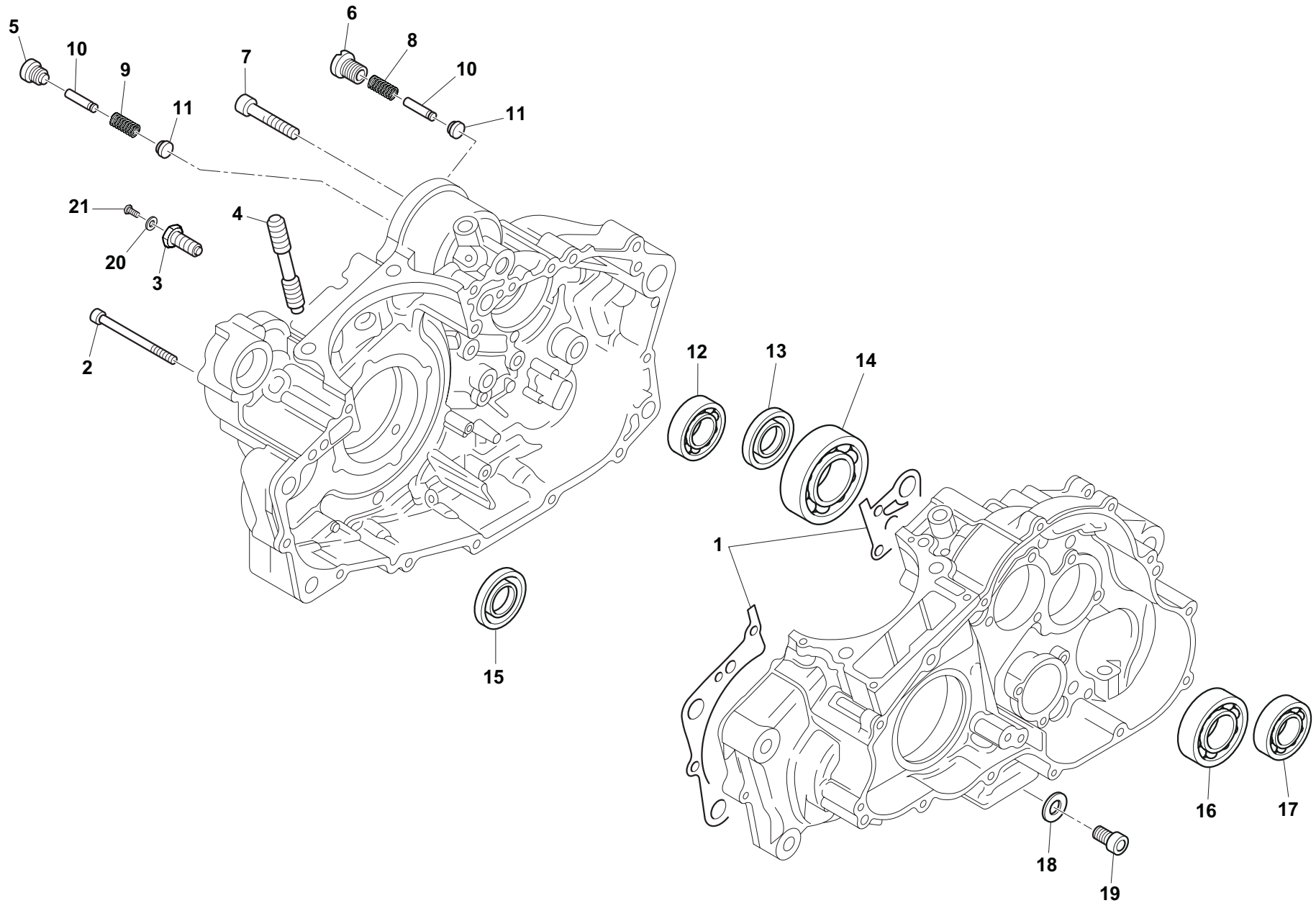

TR 650 Terra/2013
TR 650 Strada/2013TAVOLA - DRAWING
TABLE - BILD - TABLA**3****CARTER - CRANKCASE**
CARTER - GEHÄUSE
BANCADA

Note Notes Notes Marke Notas	Pos. No. Index Pos.	N. Cod. Code No. Nr. Code Code Nr N. Cod.	Q.tà Q.ty Q.te M.ge C.ad	DENOMINAZIONE	NAME	DESIGNATION	BESHREIBUNG	DENOMINACION
	1	7700338	1	Guarnizione	Gasket	Joint	Dichtung	Junta
	2	7700284	3	Vite flangiata	Flanged screw	Vis bridée	Flanschschraube	Tornillo con brida
M10	3	7700300	1	Vite	Screw	Vis	Schraube	Tornillo
M10x223	4	7700238	4	Prigioniero	Stud bolt	Prisonnier	Stiftschraube	Prisionero
	5	7700109	1	Guida perno valvola	Valve pin guide	Guide axe soupape	Ventilführung	Guía eje válvula
M12x1	6	7700251	1	Tappo filettato	Threaded plug	Bouchon fileté	Stopfen	Tapón roscado
M6x45	7	7700283	11	Vite	Screw	Vis	Schraube	Tornillo
	8	7700110	1	Molla per valvola	Valve spring	Ressort pour soupape	Feder für Ventil	Muelle para válvula
	9	7700222	1	Molla per valvola	Valve spring	Ressort pour soupape	Feder für Ventil	Muelle para válvula
	10	7700111	2	Perno valvole	Valve pin	Axe	Bolzen	Eje
	11	7700112	2	Valvola pressione	Constant pressure valve	Soupape	Ventil	Válvula
	12	7700322	1	Cuscinetto	Bearing	Roulement	Lager	Cojinete
Ø15xØ24x7	13	7700117	1	Anello di tenuta	Sealing ring	Bague d'étanchéité	Dichtungsring	Anillo de estanqueidad
	14	7700261	1	Cuscinetto	Bearing	Roulement	Lager	Cojinete
Ø25xØ40x7	15	7700116	1	Anello di tenuta	Sealing ring	Bague d'étanchéité	Dichtungsring	Anillo de estanqueidad
	16	7700115	1	Cuscinetto	Bearing	Roulement	Lager	Cojinete
	17	7700114	1	Cuscinetto	Bearing	Roulement	Lager	Cojinete
	18	7700202	1	Guarnizione di tenuta	Gasket ring	Joint d'étanchéité	Dichtung	Junta de estanqueidad
M8x20	19	7700285	1	Vite TE/Torx flangiata	Hex./Torx flanged screw	Vis de bride TE/Torx	SK/Torx-Bundschraube	Perno de reborde TE/Torx
	20	7719364	1	Guarnizione	Gasket	Joint	Dichtung	Junta
	21	7719365	1	Vite	Screw	Vis	Schraube	Tornillo

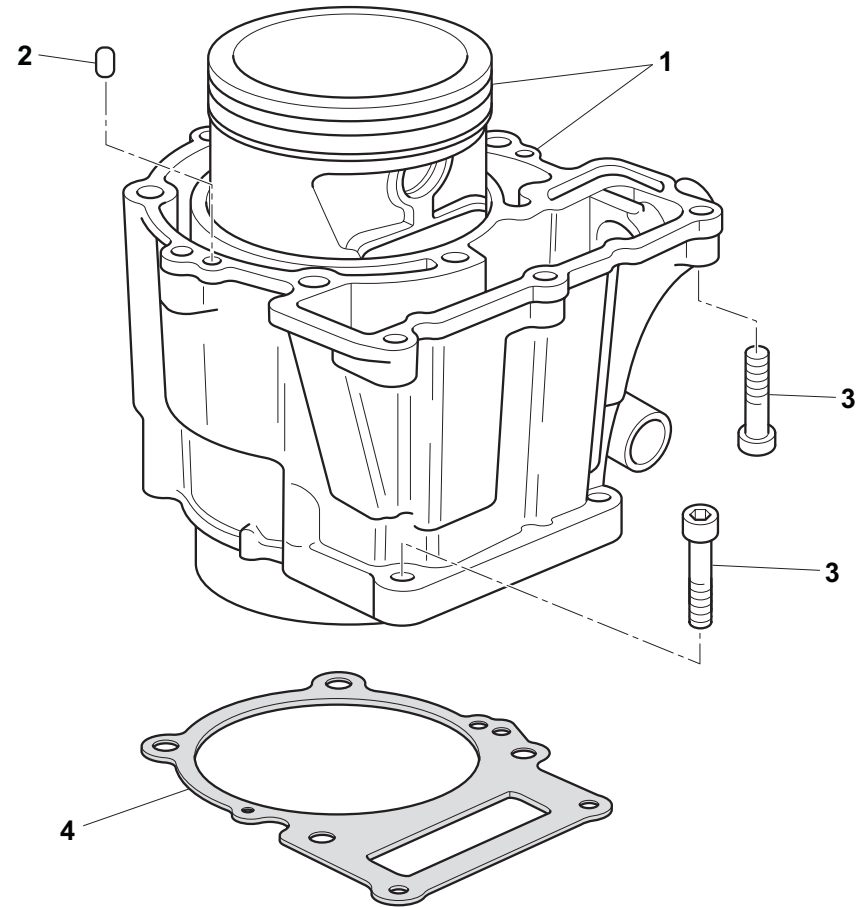
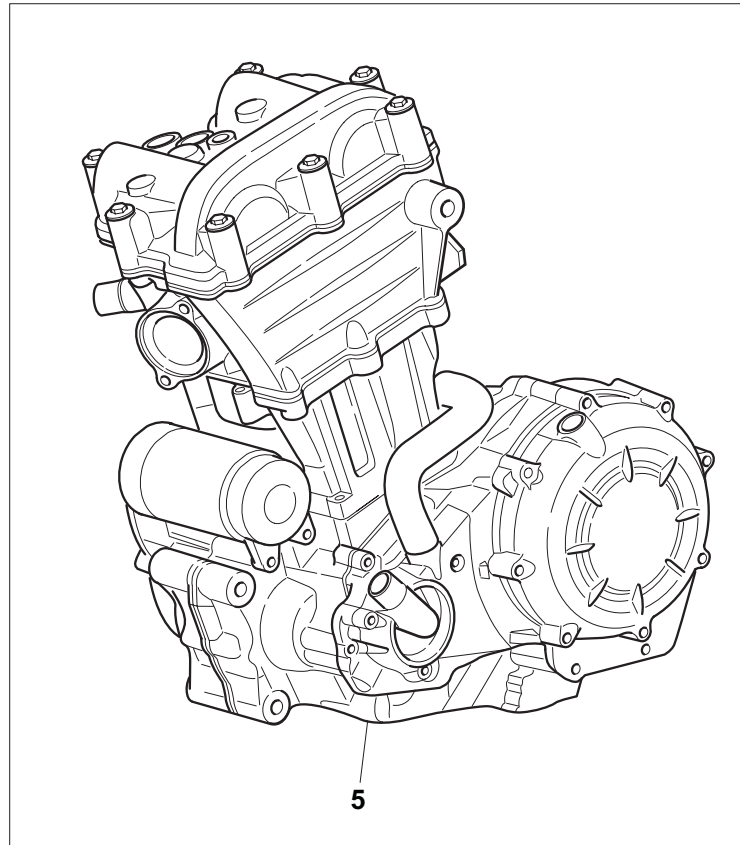

TR 650 Terra/2013
TR 650 Strada/2013

TAVOLA - DRAWING
TABLE - BILD - TABLA

4

MOTORE - ENGINE
MOTEUR - MOTOR
MOTOR



Note Notes Marke Notas	Pos. No. Index Pos.	N. Cod. Code No. Nr. Code Code Nr N. Cod.	Q.tà Q.ty Q.te M.ge C.ad	DENOMINAZIONE	NAME	DESIGNATION	BESHREIBUNG	DENOMINACION
	1	8539152	1	Assieme cilindro pistone	Cylinder and piston set	Cylindre avec piston compl.	Zusammenbau Zylinder mit Kolben	Conjunto cilindro con pistón
	2	7700337	2	Spina	Pin	Goupille	Stift	Clavija
M6x30	3	7700281	5	Vite TE/Torx flangiata	Hex./Torx flanged screw	Vis de bride TE/Torx	SK/Torx-Bundschaube	Perno de reborde TE/Torx
	4	7700118	1	Guarnizione	Gasket	Joint	Dichtung	Junta
	5	8000H5206	1	Assieme motore	Engine assy	Moteur compl.	Zusammenbau Motor	Conjunto motor

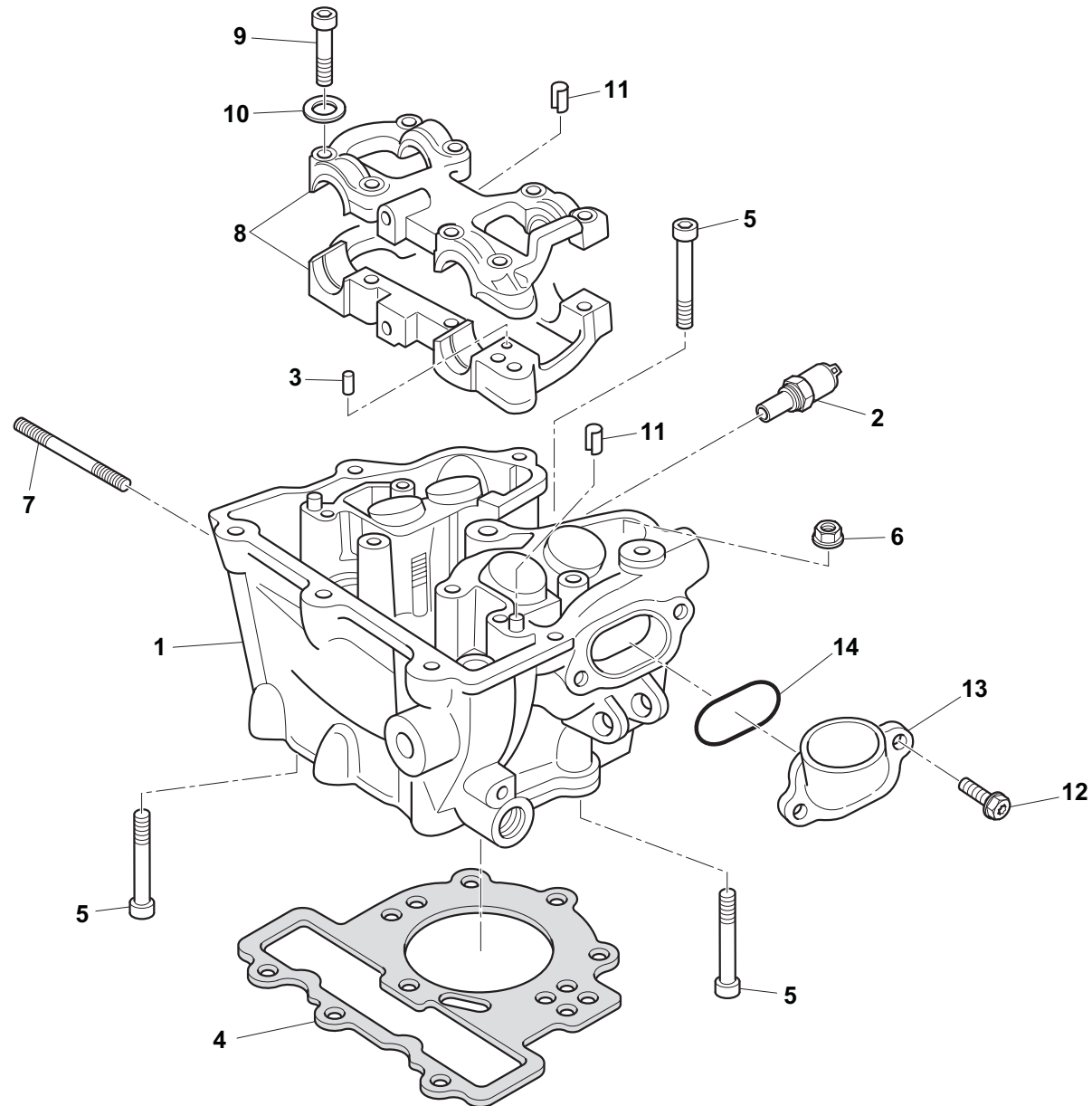

**TR 650 Terra/2013
TR 650 Strada/2013**

TAVOLA - DRAWING
TABLE - BILD - TABLA

5

**TESTA CILINDRO - CYLINDER HEAD
CULASSE - ZYLINDERKOPF
CULATA**



Note Notes Notas	Pos. No. Index Pos.	N. Cod. Code No. Nr. Code Code Nr N. Cod.	Q.tà Q.ty Q.te M.ge C.ad	DENOMINAZIONE	NAME	DESIGNATION	BESHREIBUNG	DENOMINACION
	1	8530440	1	Testa cilindro	Cylinder head	Culasse	Zylinderkopf	Culata
	2	7700108	1	Sensore temperatura acqua	Temperature sensor	Capteur de température	Temperatursensor	Sensor temperatura
	3	7700337	1	Perno	Pin	Axe	Bolzen	Eje
	4	7700303	1	Guarnizione testa cilindro	Cylinder head gasket	Joint couvercle culasse	Dichtung Zylinderkopf	Junta tapa culata
M8x53,5	5	7700257	5	Vite TCEI	Allen screw	Vis TCEI	Zyl. Schraube	Tornillo TCEI
M10	6	7700392	4	Dado	Nut	Écrou	Mutter	Tuerca
M8x23	7	7700223	2	Prigioniero	Stud bolt	Prisonnier	Stiftschraube	Prisionero
	8	7700199	1	Staffa	Bracket	Etrier	Bügel	Estribo
M6x45	9	7700283	8	Vite flangiata	Flanged screw	Vis bridée	Flanschschrabe	Tornillo con brida
	10	7700339	8	Rondella	Washer	Rondelle	Unterlegscheibe	Arandela
Ø8,4x14	11	7700191	3	Spina elastica	Elastic pin	Goupille élastique	Spannstift	Clavija elástica
M8x20	12	7700285	2	Vite TE/Torx flangiata	Hex./Torx flanged screw	Vis de bride TE/Torx	SK/Torx-Bundschraube	Perno de reborde TE/Torx
	13	8530438	1	Collettore	Manifold	Collecteur	Krümmmer	Colector
	14	8530439	1	Guarnizione testa	Head gasket	Joint Culasse	Zylinderkopfdichtung	Junta culata

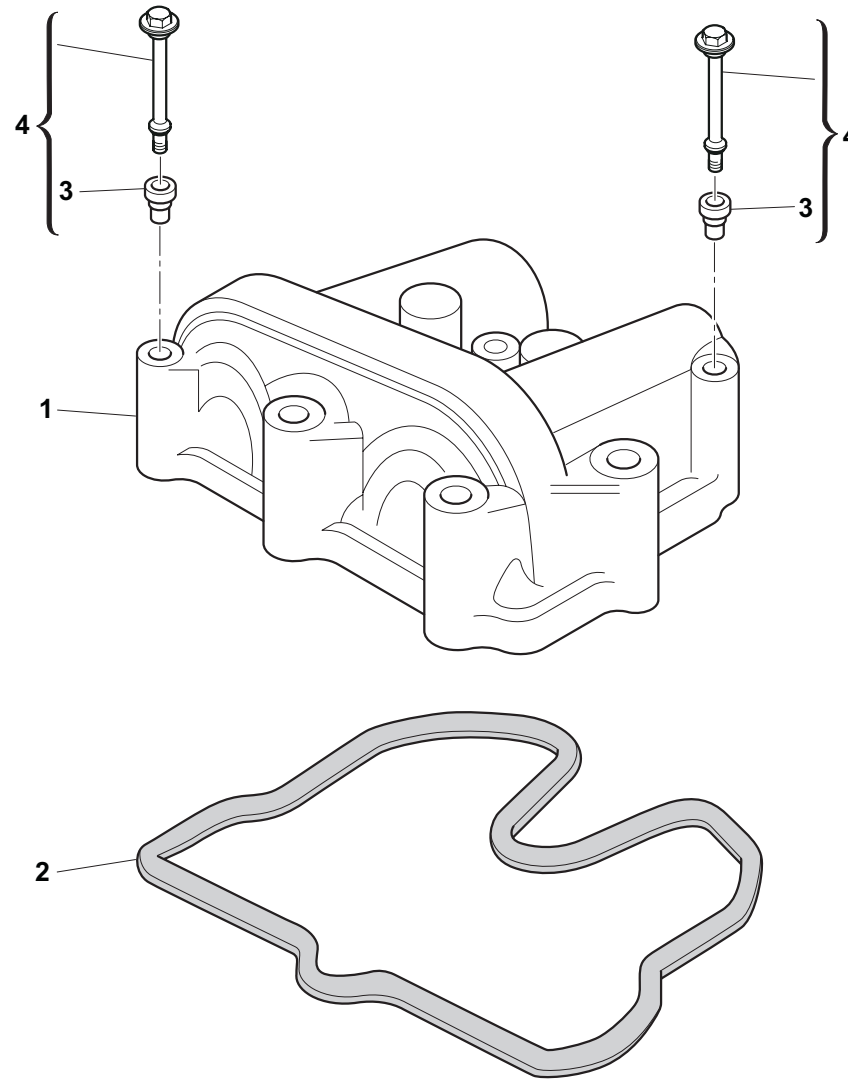

TR 650 Terra/2013
TR 650 Strada/2013

TAVOLA - DRAWING
 TABLE - BILD - TABLA

6

COPERCHIO VALVOLE - VALVE COVER
COUVERCLE - VENTILDECKEL
TAPA VALVULE



Note Notes Marke Notas	Pos. No. Index Pos.	N. Cod. Code No. Nr. Code Code Nr N. Cod.	Q.tà Q.ty M.ge C.ad	DENOMINAZIONE	NAME	DESIGNATION	BESHREIBUNG	DENOMINACION
	1	8530461	1	Coperchio testa	Head cover	Couvercle culasse	Zylinderkopfdeckel	Tapa culata
	2	7700196	1	Guarnizione coperchio testa	Head cover gasket	Joint couvercle culasse	Dichtung Zylinderkopfdeckel	Junta tapa culata
	3	7700105	8	Bussola	Rubber bush	Douille	Buchse	Casquillo
M6x48	4	7700192	8	Vite	Screw	Vis	Schraube	Tornillo

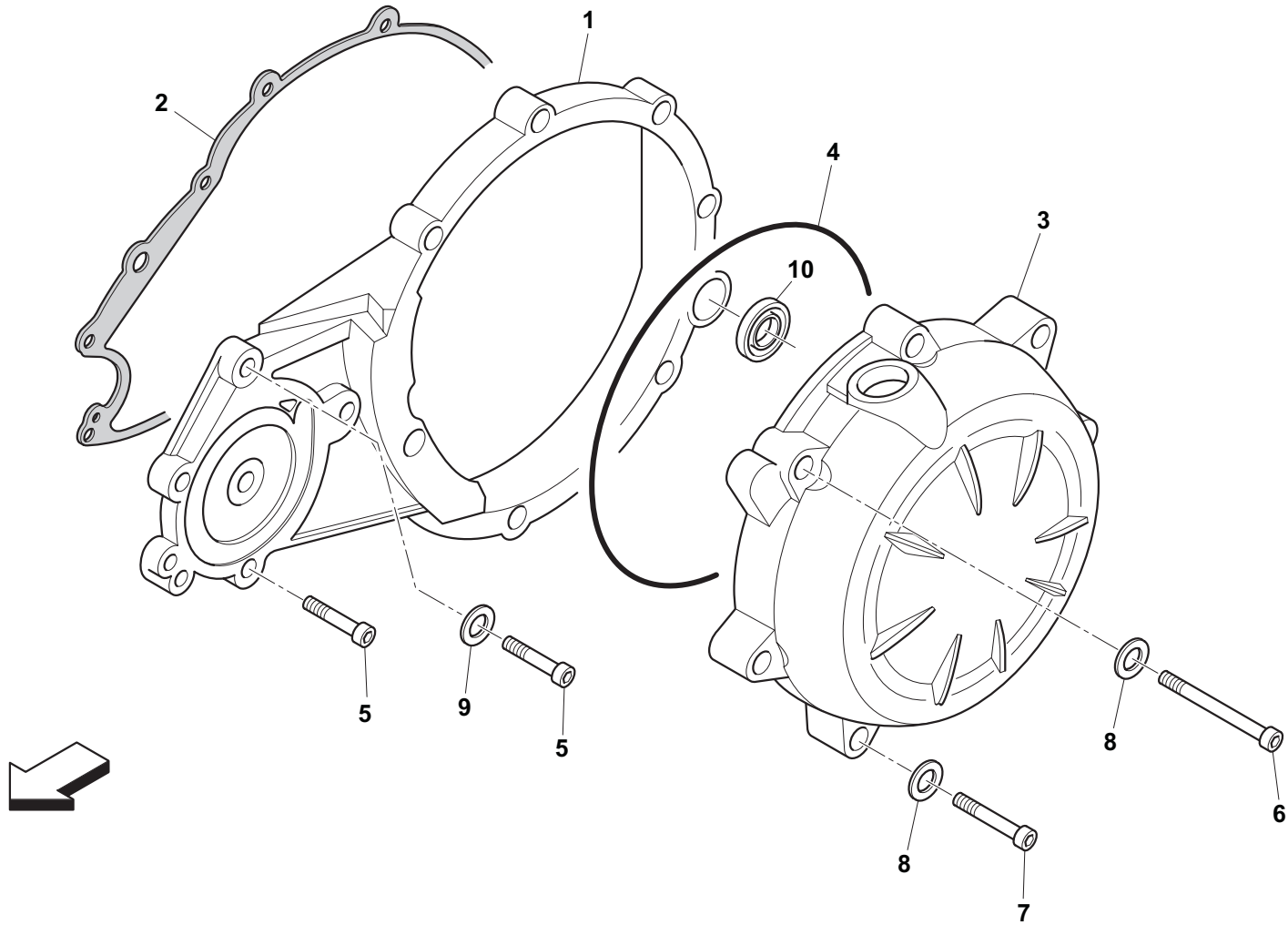

**TR 650 Terra/2013
TR 650 Strada/2013**

TAVOLA - DRAWING
TABLE - BILD - TABLA

7

**COPERCHIO FRIZIONE - CLUTCH COVER
COUVERCLE D'EMBRAYAGE - KUPPLUNGSDECKEL
TAPA EMBRAGUE**



Note Notes Marka Notas	Pos. No. Index Pos.	N. Cod. Code No. Nr. Code Code Nr N. Cod.	Q.tà Q.ty Q.te M.ge C.ad	DENOMINAZIONE	NAME	DESIGNATION	BESHREIBUNG	DENOMINACION
	1	7700312	1	Coperchio frizione	Clutch cover	Couvercle d'embrayage	Kupplungsdeckel	Tapa embrague
	2	7700313	1	Guarnizione	Gasket	Joint	Dichtung	Junta
	3	8530595	1	Coperchio frizione	Clutch cover	Couvercle d'embrayage	Kupplungsdeckel	Tapa embrague
	4	7700194	1	Anello OR	O-ring	Joint torique	O-Ring	Junta tórica
M6x30	5	7700281	10	Vite TC/Torx	Allen/Torx screw	Vis TC/Torx	Zyl./Torx Schraube	Tornillo TC/Torx
M6x85	6	7700399	3	Vite TC/Torx	Allen/Torx screw	Vis TC/Torx	Zyl./Torx Schraube	Tornillo TC/Torx
M6x40	7	7700400	5	Vite TC/Torx	Allen/Torx screw	Vis TC/Torx	Zyl./Torx Schraube	Tornillo TC/Torx
	8	7711609	10	Rondella in alluminio	Washer	Rondelle	Unterlegscheibe	Arandela
	9	7700248	1	Guarnizione di tenuta	Gasket ring	Joint d'étanchéité	Dichtung	Junta de estanqueidad
Ø12xØ28x7	10	7700121	1	Anello di tenuta	Sealing ring	Bague d'étanchéité	Dichtungsring	Anillo de estanqueidad

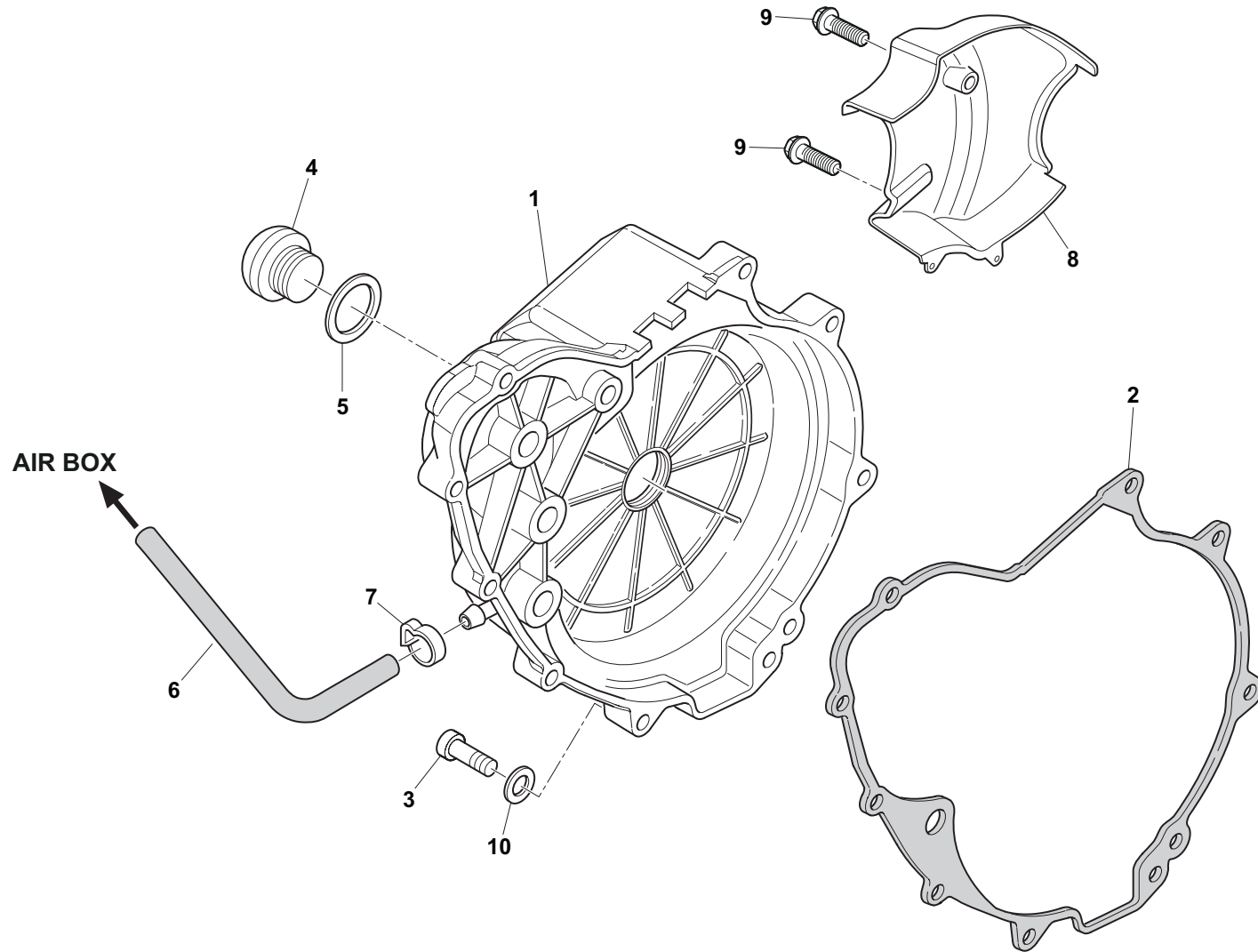

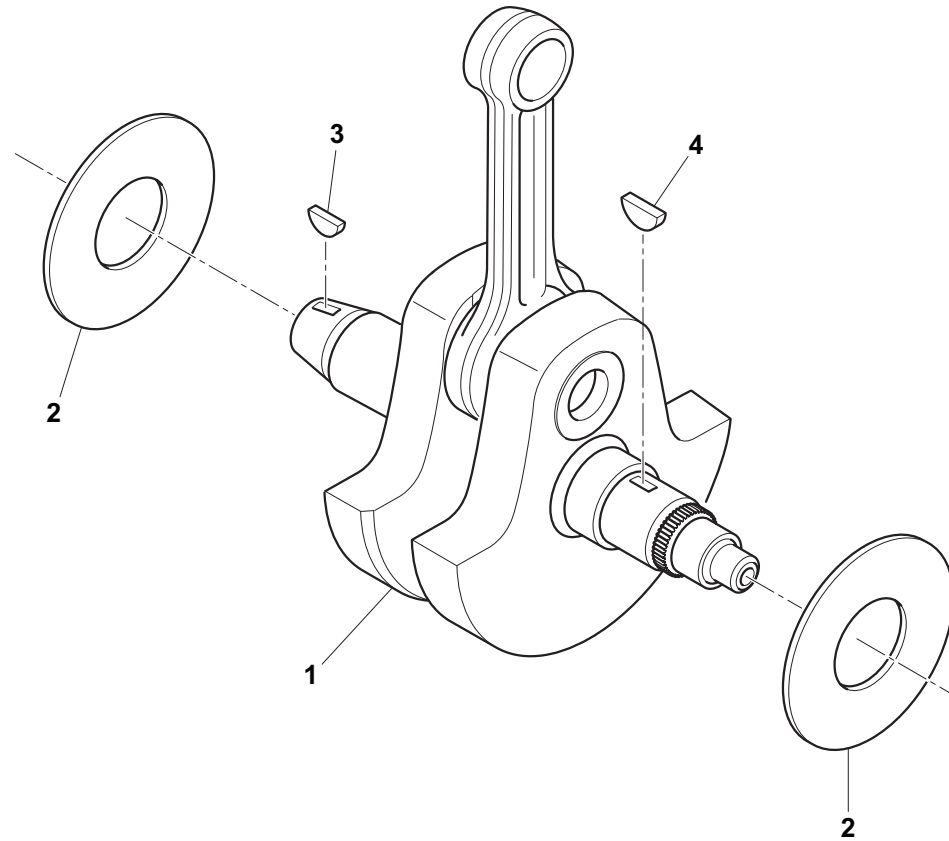

MANOVELLISMO - CRANKSHAFT
VILEBREQUIN - KURBELWELLE
CIGÜEÑAL

Note Notes Notes Marke Notas	Pos. No. Index Pos.	N. Cod. Code No. Nr. Code Code Nr N. Cod.	Q. tà Q. ty Q. te M. ge C. ad	DENOMINAZIONE	NAME	DESIGNATION	BESHREIBUNG	DENOMINACION
	1	8530458	1	Albero motore completo	Complete crankshaft	Vilebrequin complet	Kurbelwelle komplett	Cigüeñal completo
Ø46xØ69x1,0	2	7700235	1	Rosetta di rasamento	Shim washer	Rondelle d'épaisseur	Zwischenlegscheibe	Arandela distanciadora
Ø46xØ69x1,6	2	7700324	1	Rosetta di rasamento	Shim washer	Rondelle d'épaisseur	Zwischenlegscheibe	Arandela distanciadora
Ø46xØ69x1,4	2	7700325	1	Rosetta di rasamento	Shim washer	Rondelle d'épaisseur	Zwischenlegscheibe	Arandela distanciadora
Ø46xØ69x1,2	2	7700326	1	Rosetta di rasamento	Shim washer	Rondelle d'épaisseur	Zwischenlegscheibe	Arandela distanciadora
4x5	3	7700170	1	Linguetta a disco	Woodruff key	Clavette à disque	Scheibenkeil	Lengüeta de disco
6x9	4	7700172	1	Linguetta a disco	Woodruff key	Clavette à disque	Scheibenkeil	Lengüeta de disco

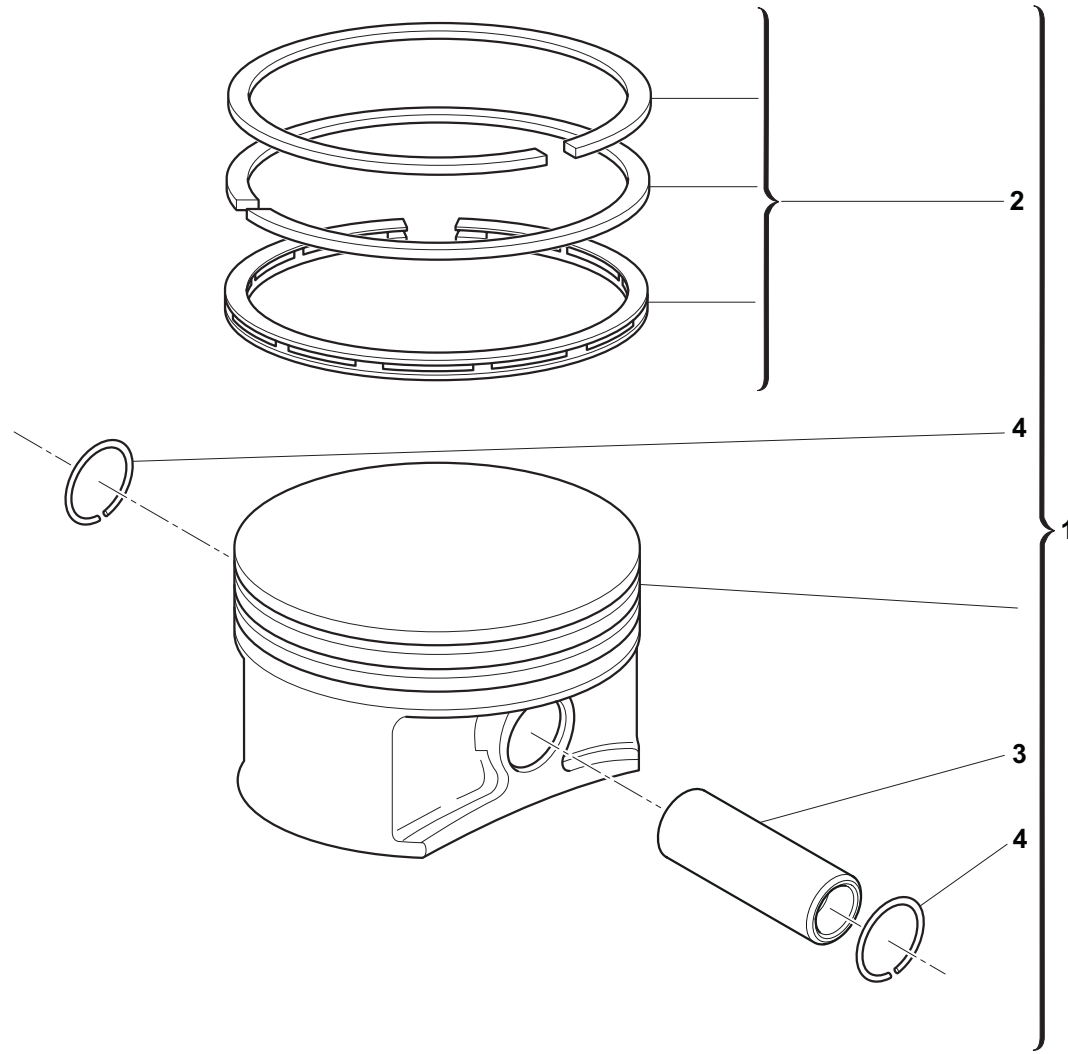

TR 650 Terra/2013
TR 650 Strada/2013

TAVOLA - DRAWING
TABLE - BILD - TABLA

10

PISTONE - PISTON
PISTON - KOLBEN
PISTON



Note Notes Marke Notas	Pos. No. Index Pos.	N. Cod. Code No. Nr. Code Code Nr N. Cod.	Q.tà Q.ty Q.te M.ge C.ad	DENOMINAZIONE	NAME	DESIGNATION	BESHREIBUNG	DENOMINACION
	1	8530452	1	Gruppo pistone	Piston assy	Ensemble piston	Kolbengruppe	Grupo pistón
	2	8530454	1	Gruppo segmenti pistone	Piston ring assy	Piston bagues compl.	Gruppe Kolbenring	Grupo anillos pistón
	3	8530453	1	Perno	Pin	Axe	Bolzen	Eje
	4	8530455	2	Anello elastico	Circlip	Circlip	Sprengring	Anillo elástico

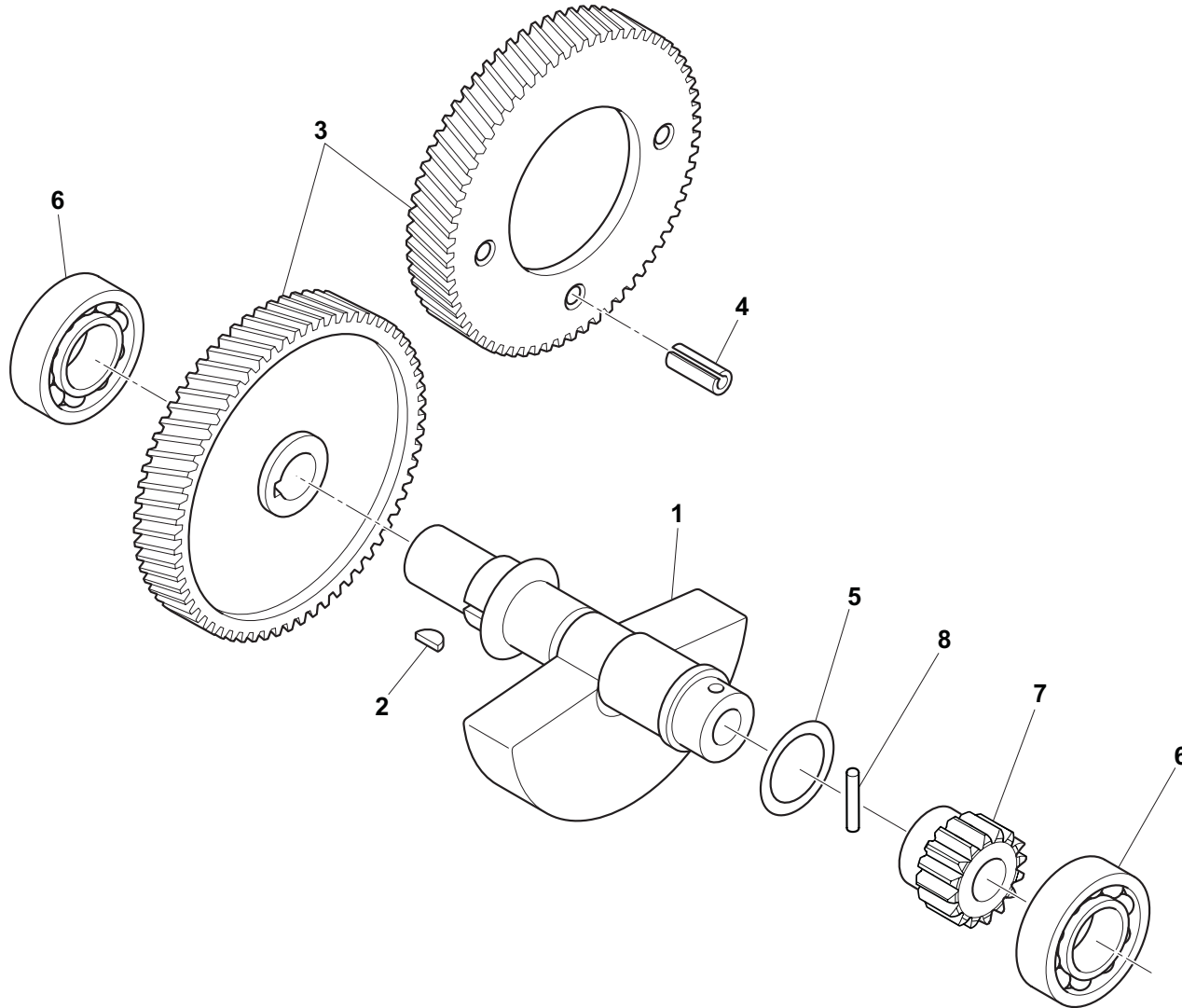

TR 650 Terra/2013
TR 650 Strada/2013

TAVOLA - DRAWING
TABLE - BILD - TABLA

11

ALBERO DI COMPENSAZIONE - BALANCE SHAFT
ARBRE DE COMPENSATION - COMPENSATIONSWELLE
EJE DE COMPENSACION



Note Notes Notes Marke Notas	Pos. No. Index Pos.	N. Cod. Code No. Nr. Code Code Nr N. Cod.	Q. tà Q. ty Q. te M. ge C. ad	DENOMINAZIONE	NAME	DESIGNATION	BESHREIBUNG	DENOMINACION
	1	8530456	1	Albero di compensazione	Balance shaft	Arbre de compensation	Kompensationswelle	Eje de compensación
4x5	2	7700170	1	Linguetta a disco	Woodruff key	Clavette à disque	Scheibenkeil	Lengüeta de disco
	3	7700249	1	Ingranaggio	Gear	Pignon	Zahnrad	Engranaje
Ø8x24	4	7700171	1	Spina elastica	Elastic pin	Goupille élastique	Spannstift	Clavija elástica
Ø20xØ41x0,8	5	7700125	1	Rosetta di rasamento	Shim washer	Rondelle d'épaisseur	Zwischenlegscheibe	Arandela distanciadora
Ø20xØ41x1,0	5	7700124	1	Rosetta di rasamento	Shim washer	Rondelle d'épaisseur	Zwischenlegscheibe	Arandela distanciadora
Ø20xØ41x1,2	5	7700328	1	Rosetta di rasamento	Shim washer	Rondelle d'épaisseur	Zwischenlegscheibe	Arandela distanciadora
Ø20xØ41x1,4	5	7700327	1	Rosetta di rasamento	Shim washer	Rondelle d'épaisseur	Zwischenlegscheibe	Arandela distanciadora
	6	7700307	2	Cuscinetto	Bearing	Roulement	Lager	Cojinete
Z=15	7	7700216	1	Ingranaggio pompa	Pump gear	Engrenage pompe	Pumpenzahnrad	Engranaje bomba
	8	7700381	1	Spina elastica	Elastic pin	Goupille élastique	Spannstift	Clavija elástica



TAVOLA 22
DRAWING 22
TABLE 22
BILD 22
TABLA 22

**TR 650 Terra/2013
TR 650 Strada/2013**

TAVOLA - DRAWING
TABLE - BILD - TABLA

12

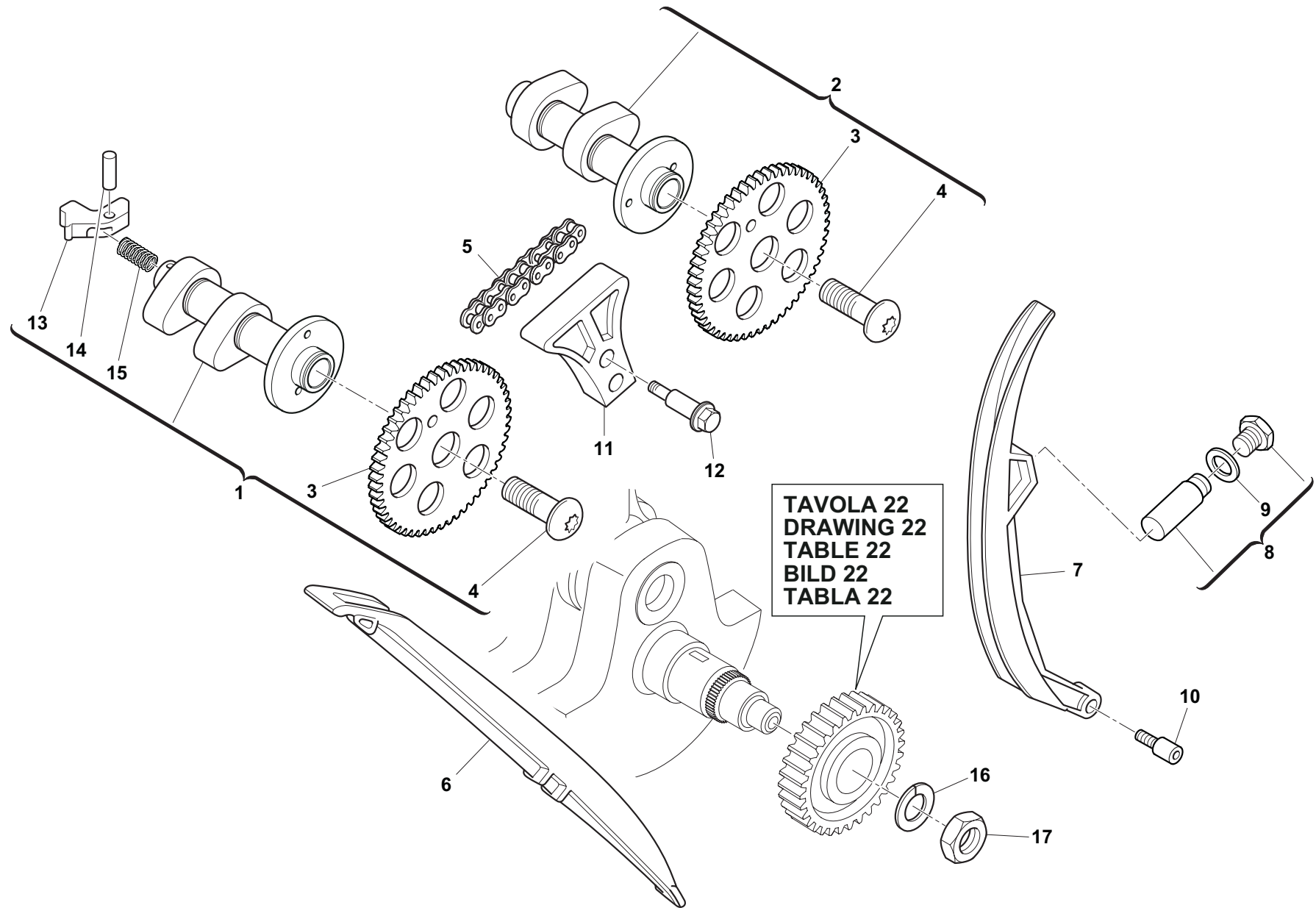
**DISTRIBUZIONE - VALVE TIMING
DISTRIBUTION - VENTILSTEUERUNG
DISTRIBUCION**



Note Notes Notas	Pos. No. Index Pos.	N. Cod. Code No. Nr. Code Code Nr N. Cod.	Q.tà Q.ty Q.te M.ge C.ad	DENOMINAZIONE	NAME	DESIGNATION	BESHREIBUNG	DENOMINACION
	1	8533980	1	Albero a camme SCARICO compl.	EXHAUST camshaft assy	Arbre à cames ÉCHAPPEMENT compl.	Nockenwelle AUSLASS kompl.	Árbol de levas ESCAPE compl.
	2	8530450	1	Albero a camme ASPIRAZIONE compl.	INTAKE camshaft assy	Arbre à cames ADMISSION compl.	Nockenwelle EINLASS kompl.	Árbol de levas ADMISIÓN compl.
Z=32	3	7700262	2	Ingranaggio distribuzione	Timing gear	Engrenage de distribution	Zahnrad	Engranaje distribución
M10x30	4	7700258	2	Vite Torx	Torx screw	Vis Torx	Torx Schraube	Tornillo Torx
	5	7700126	1	Catena distribuzione 8x3/16x126	Timing chain 8x3/16x126	Chaîne de distribution 8x3/16x126	Ventilsteuerkette 8x3/16x126	Cadena distribución 8x3/16x126
	6	7700218	1	Pattino catena	Chain slider	Patin chaîne	Kettenspannerauflage	Patín cadena
	7	7700217	1	Pattino catena	Chain slider	Patin chaîne	Kettenspannerauflage	Patín cadena
	8	7700404	1	Tendicatena completo	Complete chain tensioner	Tendeur de chaîne complet	Kettenspanner komplett	Tensor de cadena completo
	9	7700128	1	Guarnizione	Gasket	Joint	Dichtung	Junta
	10	7700299	1	Vite	Screw	Vis	Schraube	Tornillo
	11	7700219	1	Piastra guidacatena	Chain guide plate	Plaque guide de chaîne	Platte Kettenführung	Placa guía cadena
M6	12	7700127	2	Vite distanziatrice	Spacer bolt	Vis	Schraube	Tornillo
	13	8540965	1	Leva alzavalvole	Decompressor lever	Levier lève-soupapes	Ventilheber	Palanca alzaválvulas
	14	7700344	1	Perno	Pin	Axe	Bolzen	Eje
	15	7700129	1	Molla	Spring	Ressort	Feder	Muelle
	16	7700385	1	Rondella	Washer	Rondelle	Unterlegscheibe	Arandela
M22x1,5	17	7700301	1	Dado	Nut	Écrou	Mutter	Tuerca

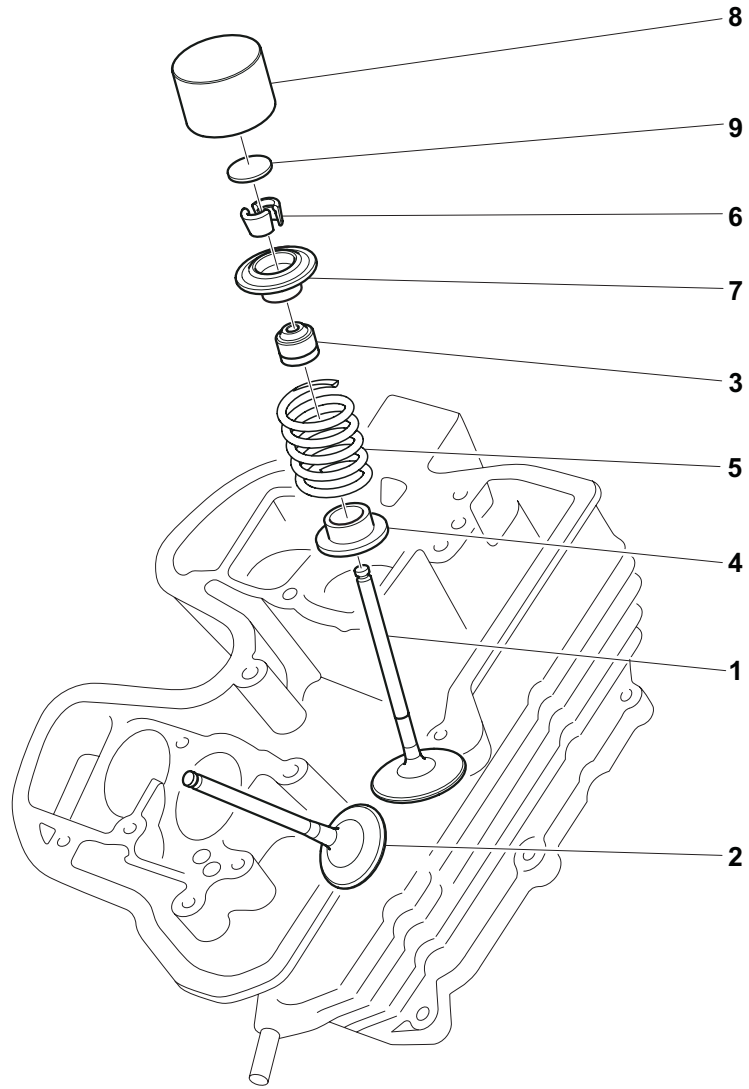

TR 650 Terra/2013
TR 650 Strada/2013

TAVOLA - DRAWING
TABLE - BILD - TABLA

13

VALVOLE - VALVES
SOUPAPES - VENTILE
VALVULAS



Note Notes Notes Marke Notas	Pos. No. Index Pos.	N. Cod. Code No. Nr. Code Code Nr N. Cod.	Q.tà Q.ty Q.te M.ge C.ad	DENOMINAZIONE	NAME	DESIGNATION	BESHREIBUNG	DENOMINACION
	1	8530447	2	Valvola aspirazione	Intake valve	Soupape d'admission	Einlassventil	Válvula de admisión
	2	8530448	2	Valvola scarico	Exhaust valve	Soupape d'échappement	Auslassventil	Válvula de escape
	3	7700315	4	Anello di tenuta valvole	Valve sealing ring	Bague d'étanchéité soupapes	Ventildichtungsring	Anillo de estanqueidad válvulas
	4	8526788	4	Molla per valvola	Valve spring	Ressort pour soupape	Feder für Ventil	Muelle para válvula
	5	7700291	4	Molla per valvola	Valve spring	Ressort pour soupape	Feder für Ventil	Muelle para válvula
	6	8533257	8	Semicono	Collet	Demi-cône	Kegelhälfte	Semicono
	7	8530449	4	Disco ritegno molle	Spring retainer disc	Disco de retenue ressorts	Rückhaltescheibe Federn	Disco retención muelles
	8	7700290	4	Alzavalvola	Valve lifter	Lève-soupape	Ventilheber	Alzaválvulas
1,80 mm	9	8523789	4	Pastiglia	Pad	Plaquette	Bremsbelag	Pastilla
1,85 mm	9	8523791	4	Pastiglia	Pad	Plaquette	Bremsbelag	Pastilla
1,90 mm	9	8523814	4	Pastiglia	Pad	Plaquette	Bremsbelag	Pastilla
1,95 mm	9	8523816	4	Pastiglia	Pad	Plaquette	Bremsbelag	Pastilla
2,00 mm	9	8523818	4	Pastiglia	Pad	Plaquette	Bremsbelag	Pastilla
2,50 mm	9	8523820	4	Pastiglia	Pad	Plaquette	Bremsbelag	Pastilla
2,10 mm	9	8523822	4	Pastiglia	Pad	Plaquette	Bremsbelag	Pastilla
2,15 mm	9	8523824	4	Pastiglia	Pad	Plaquette	Bremsbelag	Pastilla
2,20 mm	9	8523826	4	Pastiglia	Pad	Plaquette	Bremsbelag	Pastilla
2,25 mm	9	8523828	4	Pastiglia	Pad	Plaquette	Bremsbelag	Pastilla
2,30 mm	9	8523830	4	Pastiglia	Pad	Plaquette	Bremsbelag	Pastilla
2,35 mm	9	8523832	4	Pastiglia	Pad	Plaquette	Bremsbelag	Pastilla
2,40 mm	9	8523834	4	Pastiglia	Pad	Plaquette	Bremsbelag	Pastilla
2,45 mm	9	8523836	4	Pastiglia	Pad	Plaquette	Bremsbelag	Pastilla
2,50 mm	9	8523838	4	Pastiglia	Pad	Plaquette	Bremsbelag	Pastilla
2,55 mm	9	8523840	4	Pastiglia	Pad	Plaquette	Bremsbelag	Pastilla
2,60 mm	9	8523842	4	Pastiglia	Pad	Plaquette	Bremsbelag	Pastilla
2,65 mm	9	8523844	4	Pastiglia	Pad	Plaquette	Bremsbelag	Pastilla
2,70 mm	9	8523846	4	Pastiglia	Pad	Plaquette	Bremsbelag	Pastilla

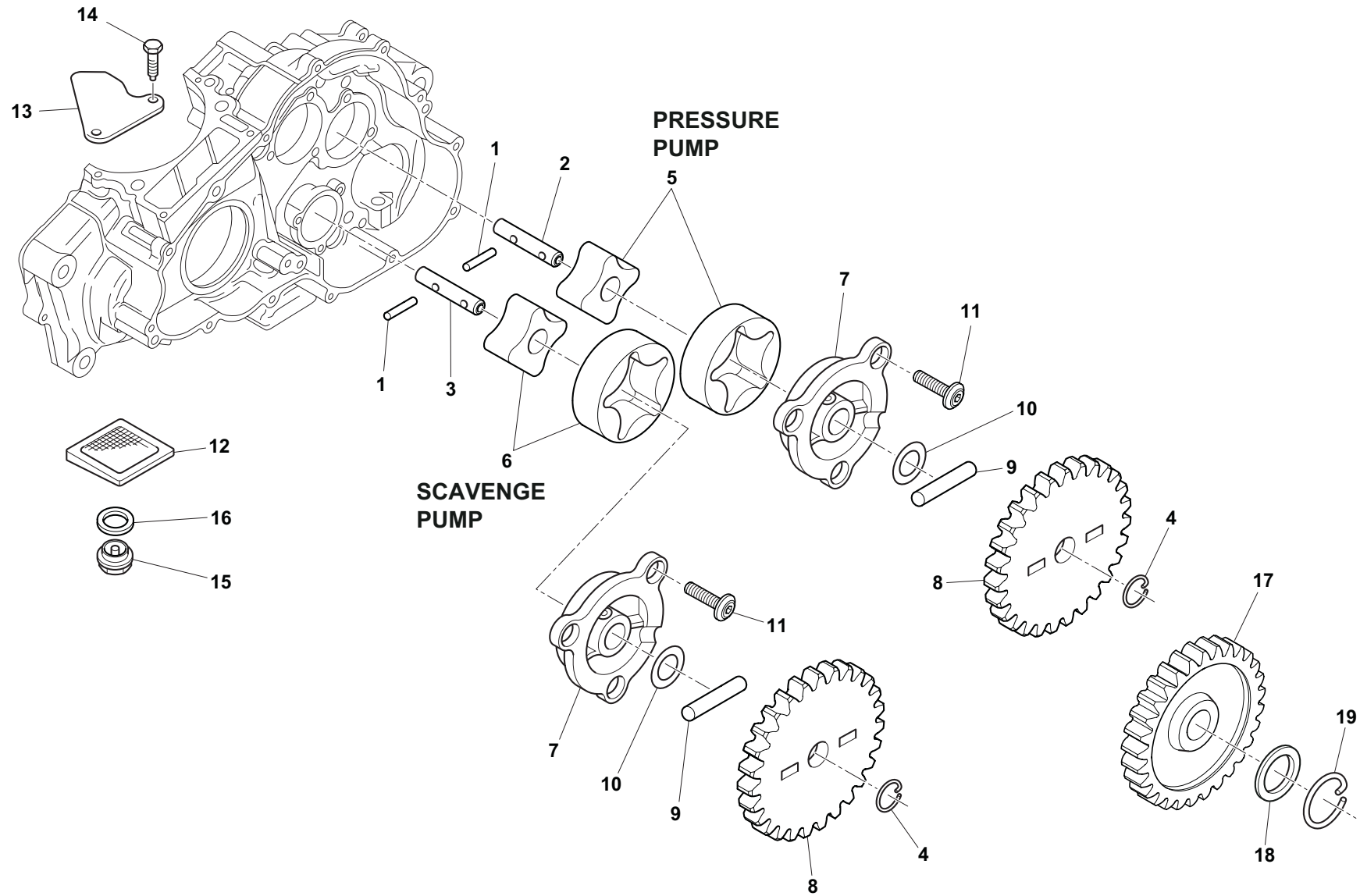

TR 650 Terra/2013
TR 650 Strada/2013

TAVOLA - DRAWING
TABLE - BILD - TABLA

14

POMPA OLIO - OIL PUMP
POMPE À HUILE - ÖLPUMPE
BOMBA ACEITE



Note Notes Notes Marke Notas	Pos. No. N. Index Pos.	N. Cod. Code No. Nr. Code Code Nr N. Cod.	Q.tà Q.ty Q.te M.ge C.ad	DENOMINAZIONE	NAME	DESIGNATION	BESHREIBUNG	DENOMINACION
	1	7700375	2	Perno	Pin	Axe	Bolzen	Eje
	2	7700221	1	Albero pompa olio	Oil pump shaft	Arbre pompe à huile	Ölpumpenwelle	Eje bomba aceite
	3	7700220	1	Albero pompa olio	Oil pump shaft	Arbre pompe à huile	Ölpumpenwelle	Eje bomba aceite
	4	7700377	2	Anello ritegno	Retaining circlip	Bague de retenue	Rückhaltering	Anillo de retención
	5	7713655	1	Rotori pompa olio di pressione	Oil rotors	Rotors huile	Öllaufräder	Rotores aceite
	6	7706730	1	Rotori pompa olio	Oil rotors	Rotors huile	Öllaufräder	Rotores aceite
	7	7700130	2	Coperchio pompa	Pump cover	Couvercle maître-cylindre	Deckel Pumpe	Tapa bomba
Z=25	8	7700132	2	Ingranaggio pompa	Pump gear	Engrenage pompe	Pumpenzahnrad	Engranaje bomba
	9	7700376	2	Perno	Pin	Axe	Bolzen	Eje
	10	7700131	2	Rondella	Washer	Rondelle	Unterlegscheibe	Arandela
M5x16	11	7700259	6	Vite Torx	Torx screw	Vis Torx	Torx Schraube	Tornillo Torx
	12	7700134	1	Filtro olio a rete	Oil sieve	Filtre à huile	Ölsieb	Filtro aceite
	13	7700378	1	Coperchio	Cover	Couvercle	Deckel	Tapa
M5x16	14	7700135	2	Vite	Screw	Vis	Schraube	Tornillo
M24x2	15	7700094	1	Vite magnetica	Magnetic screw	Vis magnétique	Magnetschraube	Tornillo magnético
Ø24xØ30x1,5	16	7700241	1	Guarnizione	Gasket	Joint	Dichtung	Junta
Z=31	17	7700133	1	Ingranaggio pompa	Pump gear	Engrenage pompe	Pumpenzahnrad	Engranaje bomba
	18	7700208	1	Rondella	Washer	Rondelle	Unterlegscheibe	Arandela
	19	7700379	1	Anello ritegno	Retaining circlip	Bague de retenue	Rückhaltering	Anillo de retención

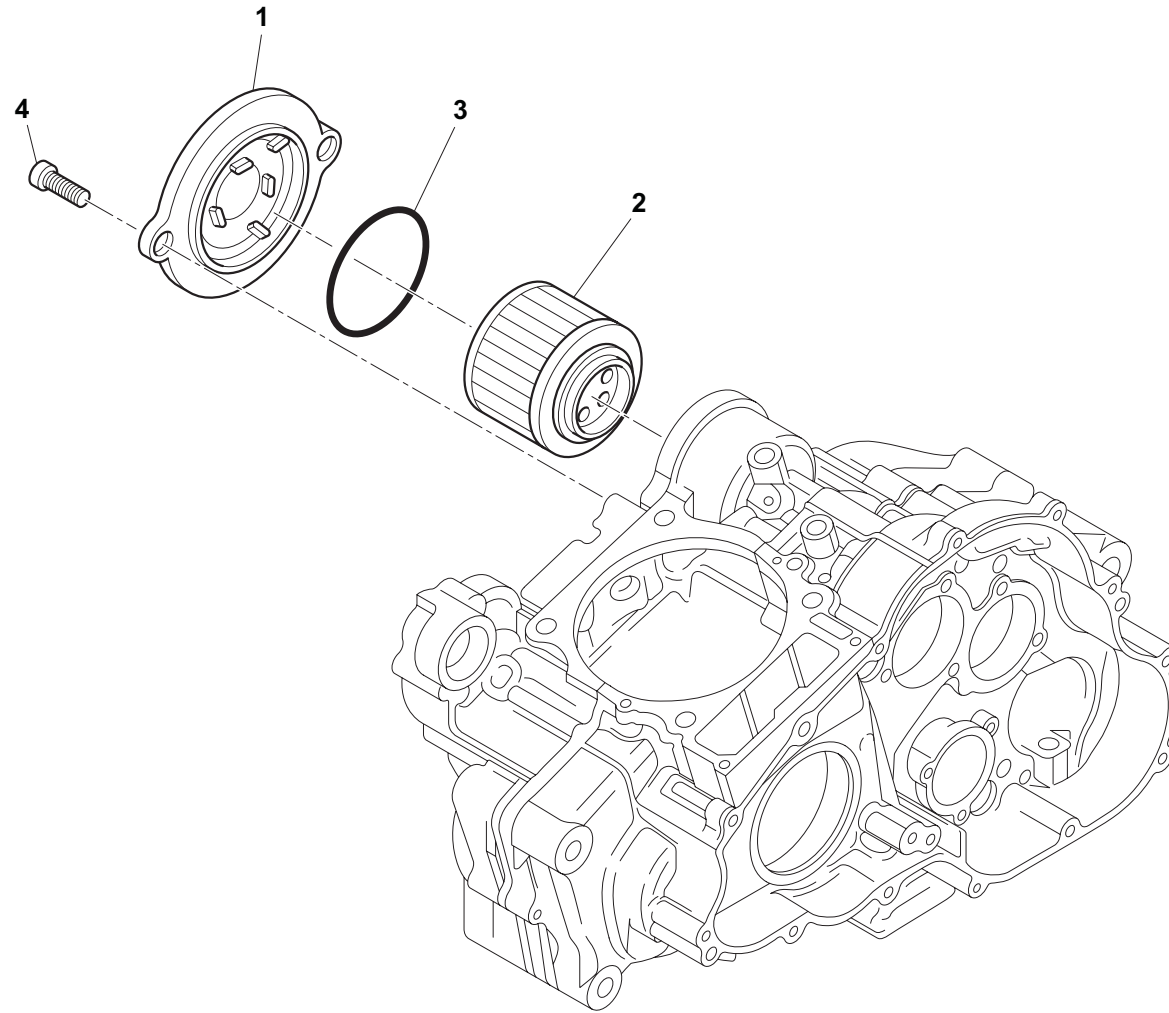

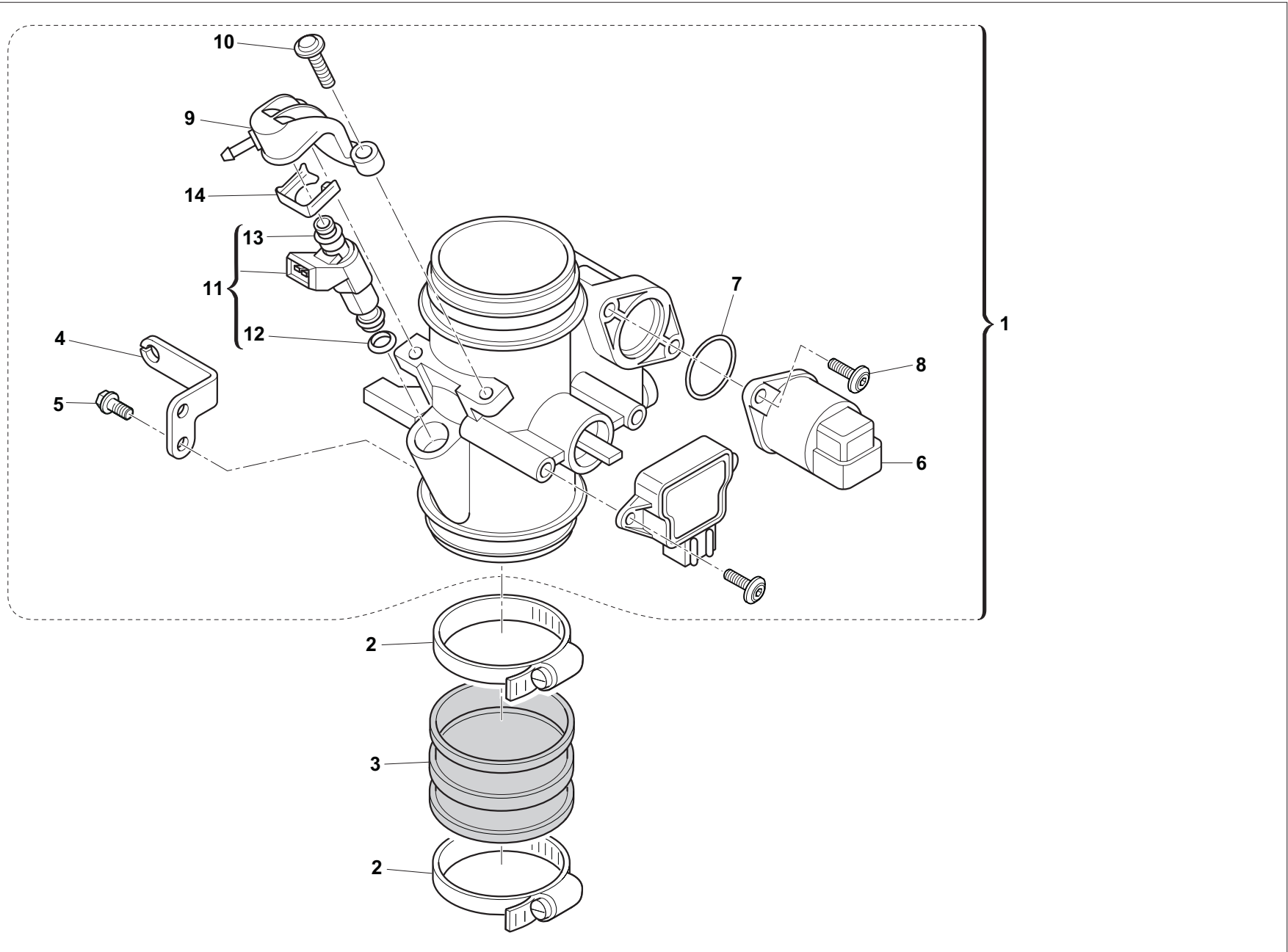

TR 650 Terra/2013
TR 650 Strada/2013

TAVOLA - DRAWING
TABLE - BILD - TABLA

16

CORPO FARFALLATO - THROTTLE BODY
CORP PAPILLON - DROSSELKLAPPENKÖRPER
CUERPO OSCILANTE



Note Notes Notes Marke Notas	Pos. No. Index Pos.	N. Cod. Code No. Nr. Code Code Nr N. Cod.	Q.tà Q.ty Q.te M.ge C.ad	DENOMINAZIONE	NAME	DESIGNATION	BESHREIBUNG	DENOMINACION
43 kW	1	7674930	1	Corpo farfallato	Throttle body	Corps à papillons	Drosselkörper	Cuerpo mariposa
USA	1	8538970	1	Corpo farfallato	Throttle body	Corps à papillons	Drosselkörper	Cuerpo mariposa
35 kW	1	8538803	1	Corpo farfallato	Throttle body	Corps à papillons	Drosselkörper	Cuerpo mariposa
	2	8526784	2	Fascetta	Clamp	Collier	Schelle	Abrazadera
	3	8530437	1	Manicotto	Coupling	Manchon	Muffe	Manguito
43 kW	4	7654888	1	Piastra cavo acceleratore	Throttle cable holder	Plaque câble accélérateur	Gaspedalkabelplatte	Placa cable acelerador
35 kW	4	8539613	1	Piastra cavo acceleratore	Throttle cable holder	Plaque câble accélérateur	Gaspedalkabelplatte	Placa cable acelerador
M5x14	5	7655405	2	Vite TE/Torx flangiata	Hex./Torx flanged screw	Vis de bride TE/Torx	SK/Torx-Bundschrabe	Perno de reborde TE/Torx
	6	7679998	1	Attuatore aria minimo	Stepper motor	Actionneur d'air minimum	Schrittmotor	Actuador aire mínimo
	7	7654909	1	Anello OR	O-Ring	Bague OR	O Ring	Anillo OR
M5x16	8	9905120	2	Vite	Screw	Vis	Schraube	Tornillo
	9	7654962	1	Fuel rail	Fuel rail	Fuel rail	Fuel Rail	Fuel rail
M5x20	10	9905121	2	Vite	Screw	Vis	Schraube	Tornillo
	11	7685373	1	Iniettore	Injector	Injecteur	Einspritzdüse	Inyector
	12	1437474	1	Anello OR	O-Ring	Bague OR	O Ring	Anillo OR
	13	7675557	1	Anello OR	O-Ring	Bague OR	O Ring	Anillo OR
	14	7688795	1	Molletta	Clip	Agrafe	Klammer	Pinza

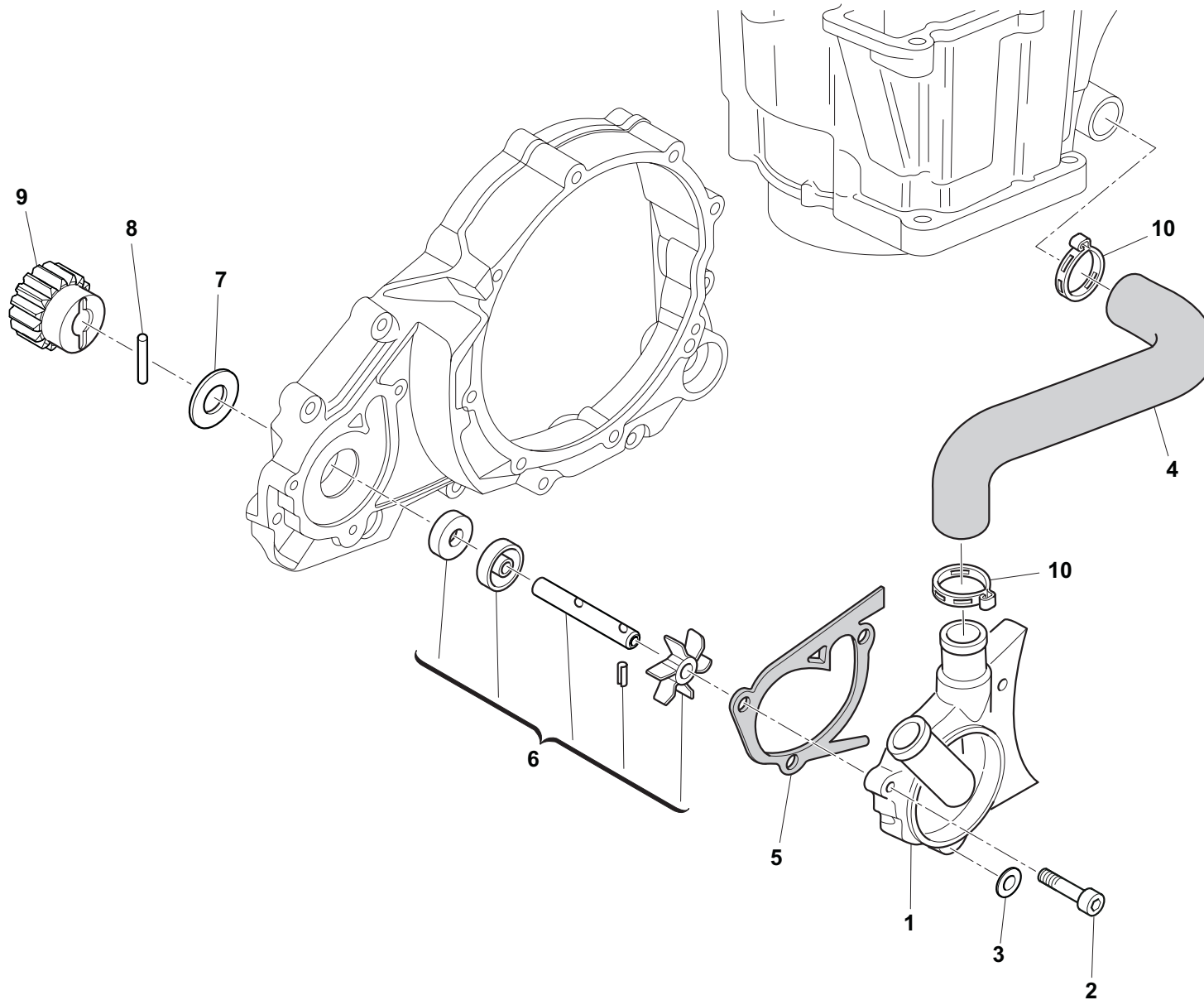

TR 650 Terra/2013
TR 650 Strada/2013

TAVOLA - DRAWING
 TABLE - BILD - TABLA

17

POMPA ACQUA - WATER PUMP
POMPE À EAU - WASSERPUMPE
BOMBA DE AGUA



Note Notes Notes Marke Notas	Pos. No. Index Pos.	N. Cod. Code No. Nr. Code Code Nr N. Cod.	Q.tà Q.ty Q.te M.ge C.ad	DENOMINAZIONE	NAME	DESIGNATION	BESHREIBUNG	DENOMINACION
M6x30	1	7700195	1	Corpo pompa acqua	Water pump body	Corps pompe à eau	Wasserpumpengehäuse	Cuerpo bomba agua
	2	7700281	3	Vite Torx	Torx screw	Vis Torx	Torx Schraube	Tornillo Torx
	3	7700248	1	Guarnizione	Gasket	Joint	Dichtung	Junta
	4	7700310	1	Tubo	Pipe	Tube	Rohr	Tubo
	5	7700382	1	Guarnizione	Gasket	Joint	Dichtung	Junta
	6	7700414	1	Kit riparazione pompa acqua	Water pump repair kit	Pompe à eau kit	Satz Wasserpumpe	Kit bomba agua
	7	7700131	1	Rondella	Washer	Rondelle	Unterlegscheibe	Arandela
	8	7700381	1	Perno	Pin	Axe	Bolzen	Eje
Z=15	9	7700216	1	Ingranaggio pompa	Pump gear	Engrenage pompe	Pumpenzahnrad	Engranaje bomba
	10	7518579	2	Fascetta	Clamp	Collier	Schelle	Abrazadera

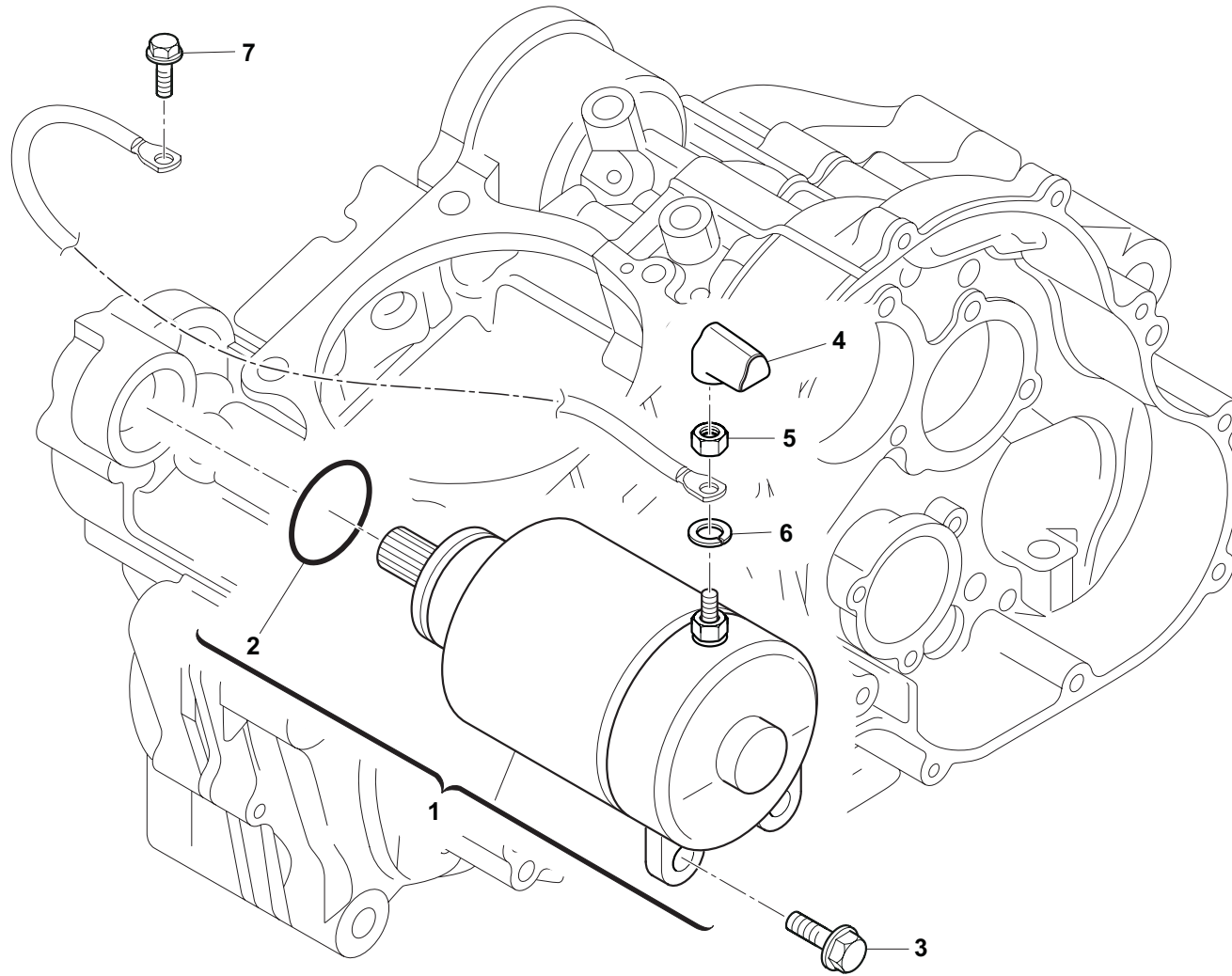

**AVVIAMENTO ELETTRICO - ELECTRIC STARTER
 DEMARREUR ELECTRIQUE - ELEKTRISCHE ANLASSER
 ARRANQUE ELECTRICO**



TAVOLA - DRAWING
 TABLE - BILD - TABLA

18

Note Notes Notes Marke Notas	Pos. No. Index Pos.	N. Cod. Code No. Nr. Code Code Nr N. Cod.	Q.tà Q.ty Q.te M.ge C.ad	DENOMINAZIONE	NAME	DESIGNATION	BESHREIBUNG	DENOMINACION
	1	7700184	1	Motorino avviamento	Starter motor	Démarreur électrique	Anlassermotor	Motor de arranque
	2	2343252	1	Anello OR	O-Ring	Bague OR	O Ring	Anillo OR
M6x30	3	7700281	2	Vite TE	Hexalobular screw	Vis TE	SK Schraube	Tornillo TE
	4	7704173	1	Cappuccio	Cap	Capuchon	Kappe	Capuchón
	5	Z00061313	1	Dado	Nut	Ecrou	Mutter	Tuerca
	6	9904427	1	Rondella	Washer	Rondelle	Unterlegscheibe	Arandela
M6x12	7	8537281	1	Vite	Screw	Vis	Schraube	Tornillo

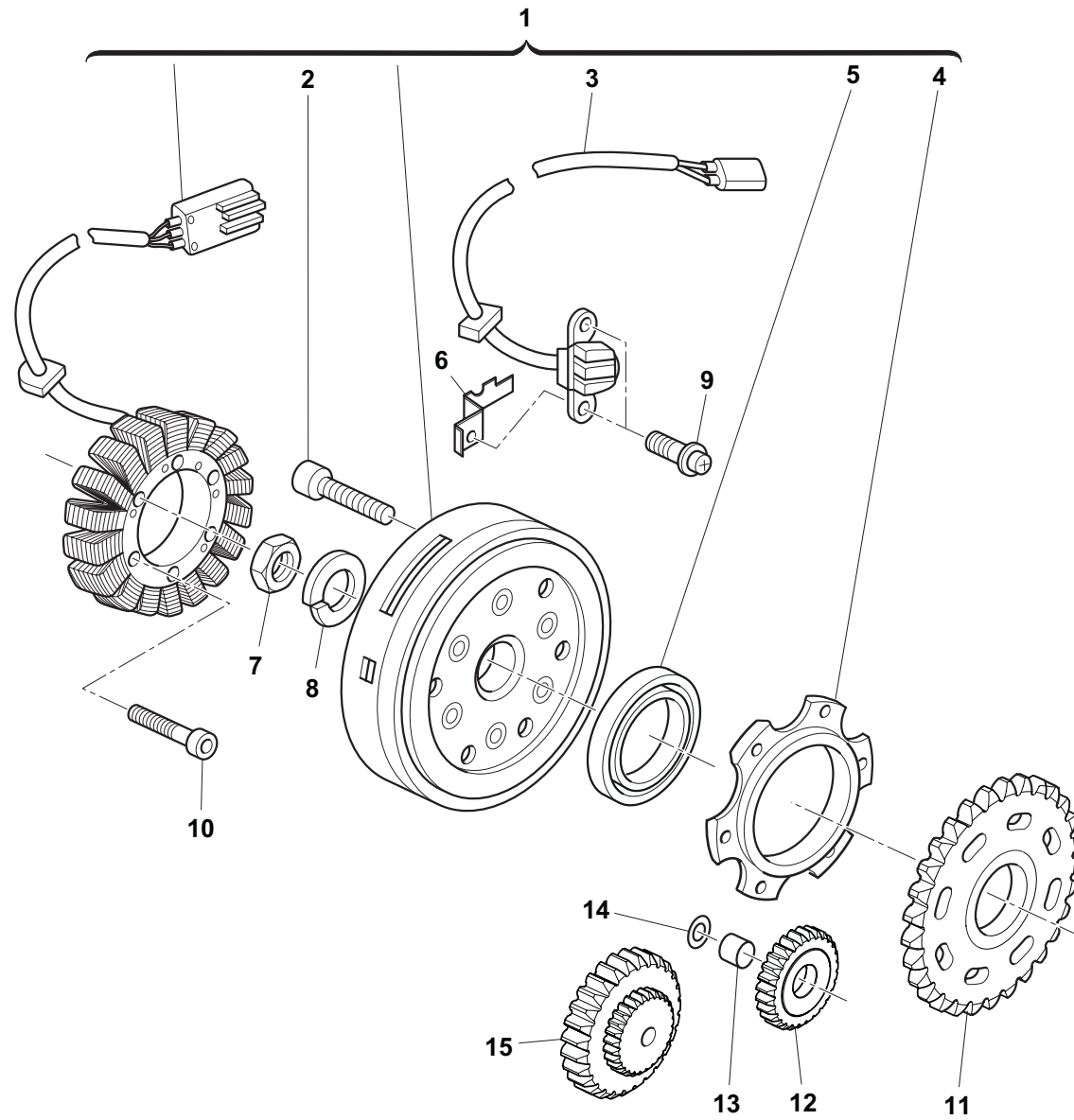

TR 650 Terra/2013
TR 650 Strada/2013

TAVOLA - DRAWING
TABLE - BILD - TABLA

19

PARTE ELETTRICA MOTORE - ENGINE ELECTRIC SYSTEM
PARTIES ELECTRIQUE MOTEUR - ELEKTISCHE ANLAGE
PARTE ELECTRICA MOTOR



Note Notes Notes Marke Notas	Pos. No. Index Pos.	N. Cod. Code No. Nr. Code Code Nr N. Cod.	Q.tà Q.ty Q.te M.ge C.ad	DENOMINAZIONE	NAME	DESIGNATION	BESHREIBUNG	DENOMINACION
	1	7715476	1	Accensione completa	Ignition unit assy	Demarrage	Generator	Encendido
M8x1,25x16	2	9903753	6	Vite TC	Allen screw	Vis TC	Zyl. Schraube	Tornillo TC
	3	7652904	1	Sensore posizione	Sensor	Capteur	Sensor	Sensor
	4	8524427	1	Flangia ruota libera	Freewheel flange	Bride roue libre	Flansch	Brida rueda libre
	5	7687777	1	Ruota libera	Freewheel	Roue libre	Freilauf	Rueda libre
	6	7700228	1	Piastrina	Plate	Plaquette	Plättchen	Placa
M22x1,5	7	7700301	1	Dado	Nut	Écrou	Mutter	Tuerca
	8	7700385	1	Rondella	Washer	Rondelle	Unterlegscheibe	Arandela
M5x16	9	7700135	2	Vite a croce	Taptite screw	Vis philips	Taptite Schraube	Tornillo
M6x35	10	7719366	3	Vite TC	Allen screw	Vis TC	Zyl. Schraube	Tornillo TC
Z=61	11	7700297	1	Ingranaggio avviamento	Starting gear	Engrenage démarreur	Anlaufzahnrad	Engranaje arranque
Z=24	12	7700137	1	Ingranaggio intermedio	Idle gear	Engrenage intermédiaire	Zwischenzahnrad	Engranaje intermedio
	13	7700226	1	Distanziale	Spacer	Entretoise	Abstandhalter	Distanciadador
	14	7700131	1	Rondella	Washer	Rondelle	Unterlegscheibe	Arandela
Z=11/52	15	7700138	1	Ingranaggio intermedio	Idle gear	Engrenage intermédiaire	Zwischenzahnrad	Engranaje intermedio

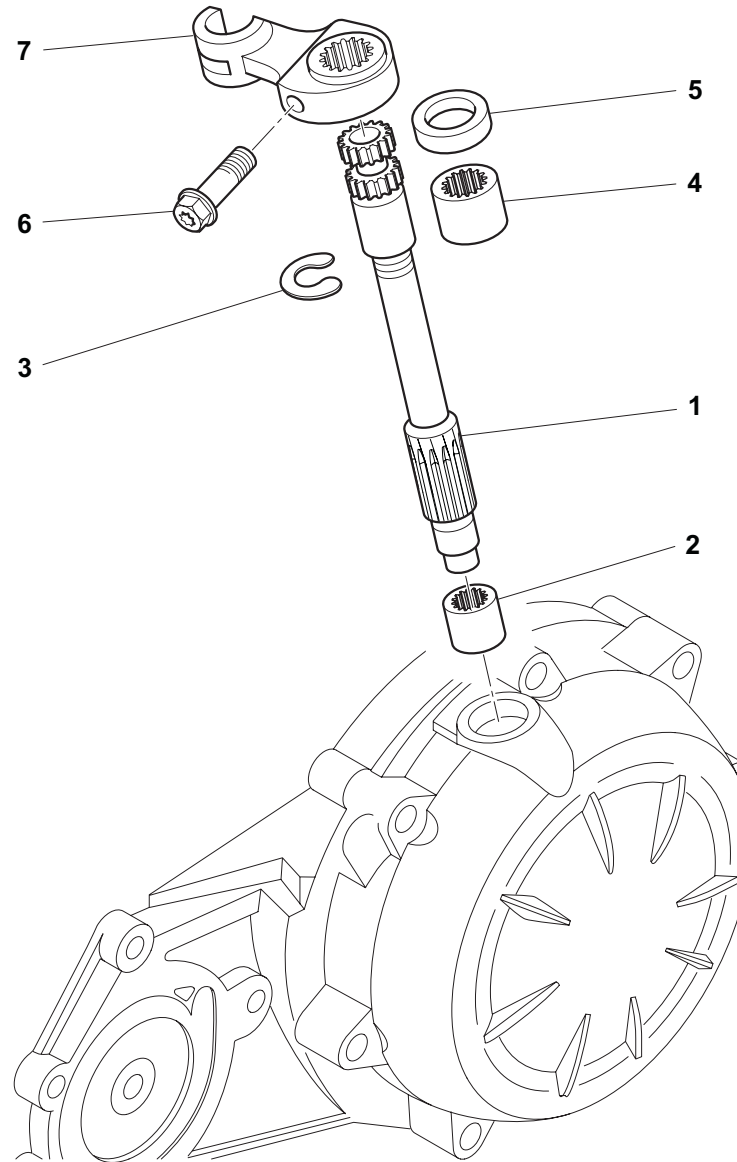

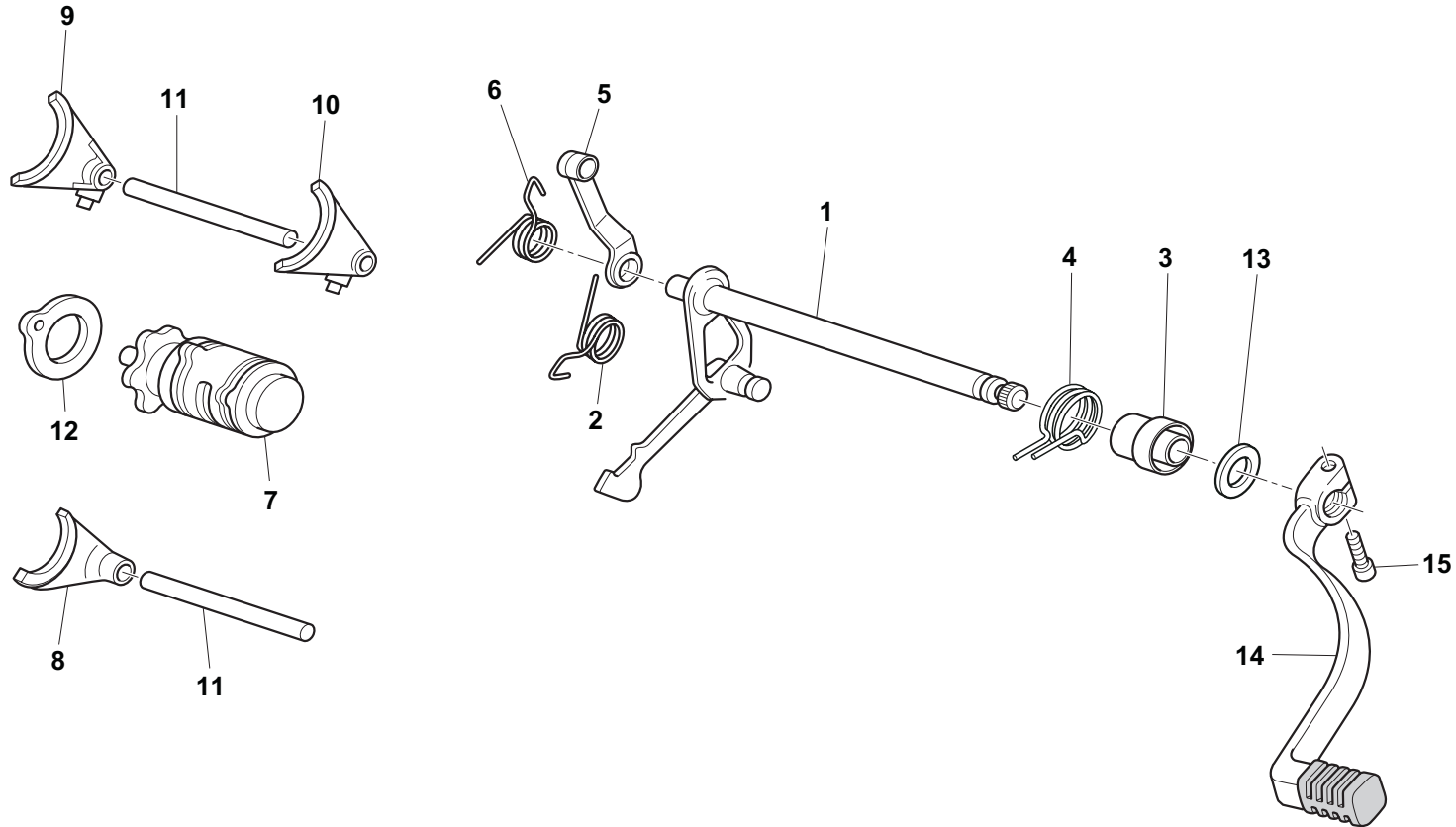

**TR 650 Terra/2013
TR 650 Strada/2013**

TAVOLA - DRAWING
TABLE - BILD - TABLA

21

**COMANDO CAMBIO - GEAR SHIFT
COMMANDE DE VITESSE - SCHALTUNG
MANDO CAMBIO**



Note Notes Marke Notas	Pos. No. Index Pos.	N. Cod. Code No. Nr. Code Code Nr N. Cod.	Q.tà Q.ty Q.te M.ge C.ad	DENOMINAZIONE	NAME	DESIGNATION	BESHREIBUNG	DENOMINACION
	1	7700236	1	Albero comando cambio	Gearbox selector shaft	Arbre com. fourches boîte de vitesses	Schaltgabelwelle	Eje mando horquillas cambio
	2	7700164	1	Molla	Spring	Ressort	Feder	Muelle
	3	7700165	1	Distanziale	Spacer	Entretoise	Abstandhalter	Distanciador
	4	7700265	1	Molla	Spring	Ressort	Feder	Muelle
	5	7700186	1	Leva	Lever	Levier	Hebel	Palanca
	6	7700166	1	Molla	Spring	Ressort	Feder	Muelle
	7	7700167	1	Tamburo desmodromico	Shift drum assy	Tambour embrayage	Kupplungstrommel	Tambor embrague
	8	7700272	1	Forcella innesto 4ª- 5ª vel.	4th and 5th gear fork	Fourche pignon 4ème-5ème	Gabel Zahnrad 4.-5.	Horquilla engranaje 4ª-5ª vel.
	9	7700271	1	Forcella innesto 2ª vel.	2nd gear fork	Fourche pignon 2ème	Gabel Zahnrad 2.	Horquilla engranaje 2ª vel.
	10	7700270	1	Forcella innesto 1ª-3ª vel.	1st and 3rd gear fork	Fourche pignon 1ème-3ème	Gabel Zahnrad 1.-3.	Horquilla engranaje 1ª-3ª vel.
	11	7700168	2	Albero	Shaft	Arbre	Welle	Árbol
	12	7700234	1	Rondella	Washer	Rondelle	Unterlegscheibe	Arandela
	13	7700159	1	Rondella	Washer	Rondelle	Unterlegscheibe	Arandela
	14	8000H6808	1	Leva comando frizione	Clutch control lever	Levier de com. embrayage	Kupplungshebel	Palanca mando embrague
M6x25	15	9907146	1	Vite	Screw	Vis	Schraube	Tornillo

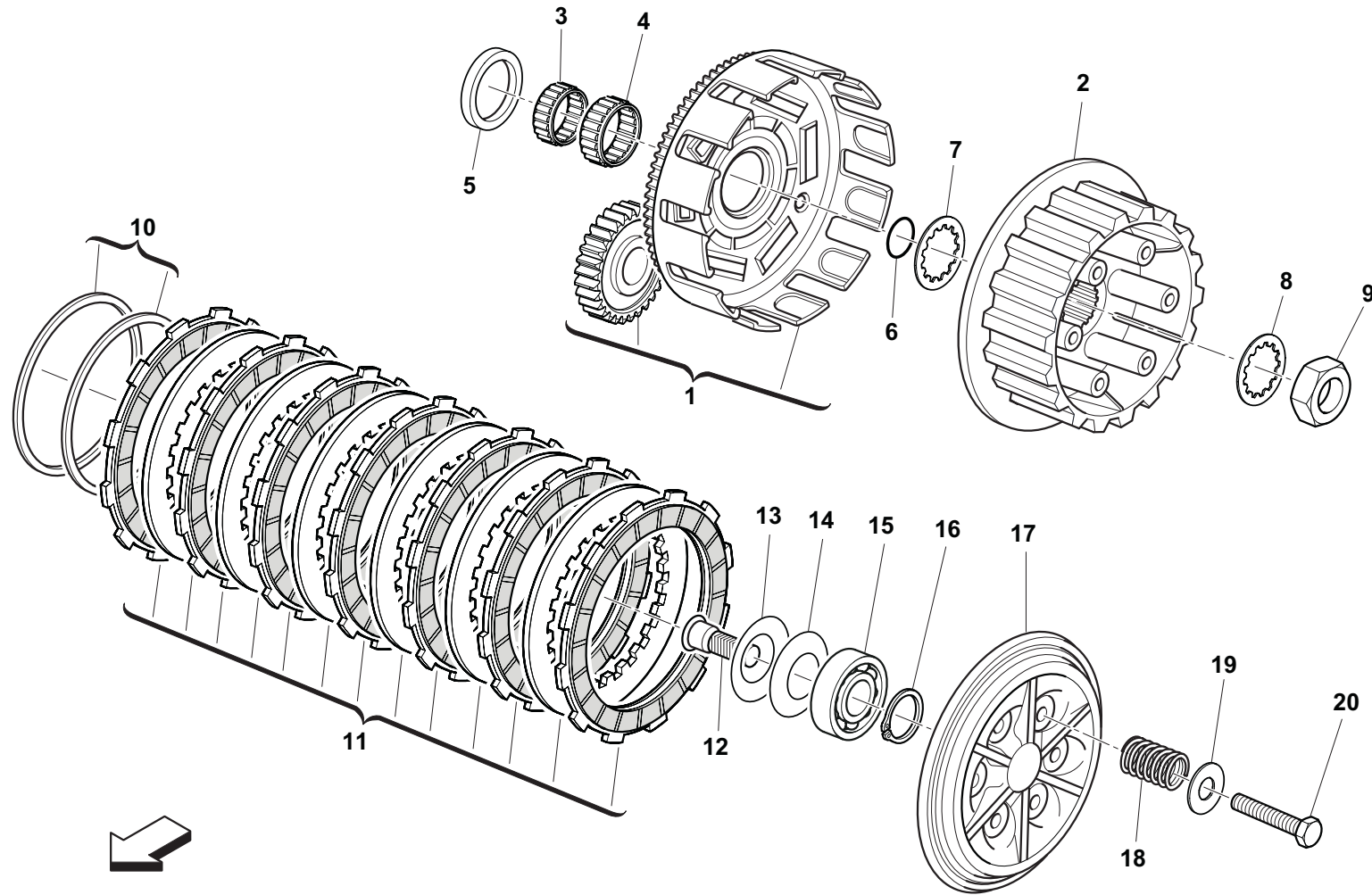

TR 650 Terra/2013
TR 650 Strada/2013

FRIZIONE - CLUTCH
EMBRAYAGE - KUPPLUNG
EMBRAGUE



TAVOLA - DRAWING
TABLE - BILD - TABLA

22

Note Notes Notes Marke Notas	Pos. No. Index Pos.	N. Cod. Code No. Nr. Code Code Nr N. Cod.	Q.tà Q.ty Q.te M.ge C.ad	DENOMINAZIONE	NAME	DESIGNATION	BESHREIBUNG	DENOMINACION
	1	7700181	1	Trasmissione primaria	Primary drive	Transmission primaire	Primärantrieb	Transmisión primaria
	2	7700246	1	Mozzo portadischi	Clutch hub	Moyeu porte-disques	Scheibennabe	Cubo portadiscos
Ø25xØ29x13	3	7700387	1	Cuscinetto a rulli	Roller bearing	Roulement à rouleaux	Rollenlager	Cojinete de rodillos
Ø25xØ29x17	4	7700139	1	Gabbia a rullini	Needle cage	Cage à aiguilles	Nadelkäfig	Jaula de rodillos
	5	7700386	1	Rasamento	Adjustament shim	Epaisseurs	Ausgleichsscheiben	distanciadora
	6	7700388	1	Anello OR	O-ring	Joint torique	O-Ring	Junta tórica
3 mm	7	7700140	1	Rosetta scanalata	Splined washer	Rondelle rainurée	Gerillte Unterlegscheibe	Arandela ranurada
	8	7700141	1	Rosetta di sicurezza	Lock washer	Rondelle-frein	Sicherungsscheibe	Arandela de seguridad
M18x1,5	9	7700183	1	Dado	Nut	Écrou	Mutter	Tuerca
	10	7714226	1	Molla-lamierino	Spring-plate	Ressort-plaquette	Feder-Blech	Muelle-chapa
	11	7700413	1	Gruppo dischi frizione	Clutch plate assy	Ensemble disques embrayage	Zsb. Kupplungsscheibenaggregat	Conj. grupo discos embrague
	12	7700308	1	Perno comando frizione	Clutch control pin	Axe commande d'embrayage	Bolzen Kupplungszug	Eje mando embrague
Ø25,7xØ14,3x0,4	13	7700144	1	Molla per frizione	Clutch spring	Ressort pour embrayage	Kupplungsfeder	Muelle para embrague
	14	7701500	1	Rondella bombata	Ball washer	Rondelle	Federscheibe	Arandela
	15	7700143	1	Cuscinetto	Bearing	Roulement	Lager	Cojinete
	16	7700379	1	Anello di fermo	Retaining ring	Bague d'arrêt	Sicherungsring	Anillo de retención
	17	7700142	1	Spingidisco frizione	Clutch pressure plate	Presse-disque embrayage	Kupplungs-Druckplatte	Plato de presión embrague
	18	7700311	6	Molla frizione	Clutch spring	Ressort d'embrayage	Kupplungsfeder	Muelle de embrague
	19	7700187	6	Distanziale	Spacer	Entretoise	Abstandhalter	Distanciad
M6x35	20	7700280	6	Vite flangiata	Flanged screw	Vis bridée	Flanschschraube	Tornillo con brida

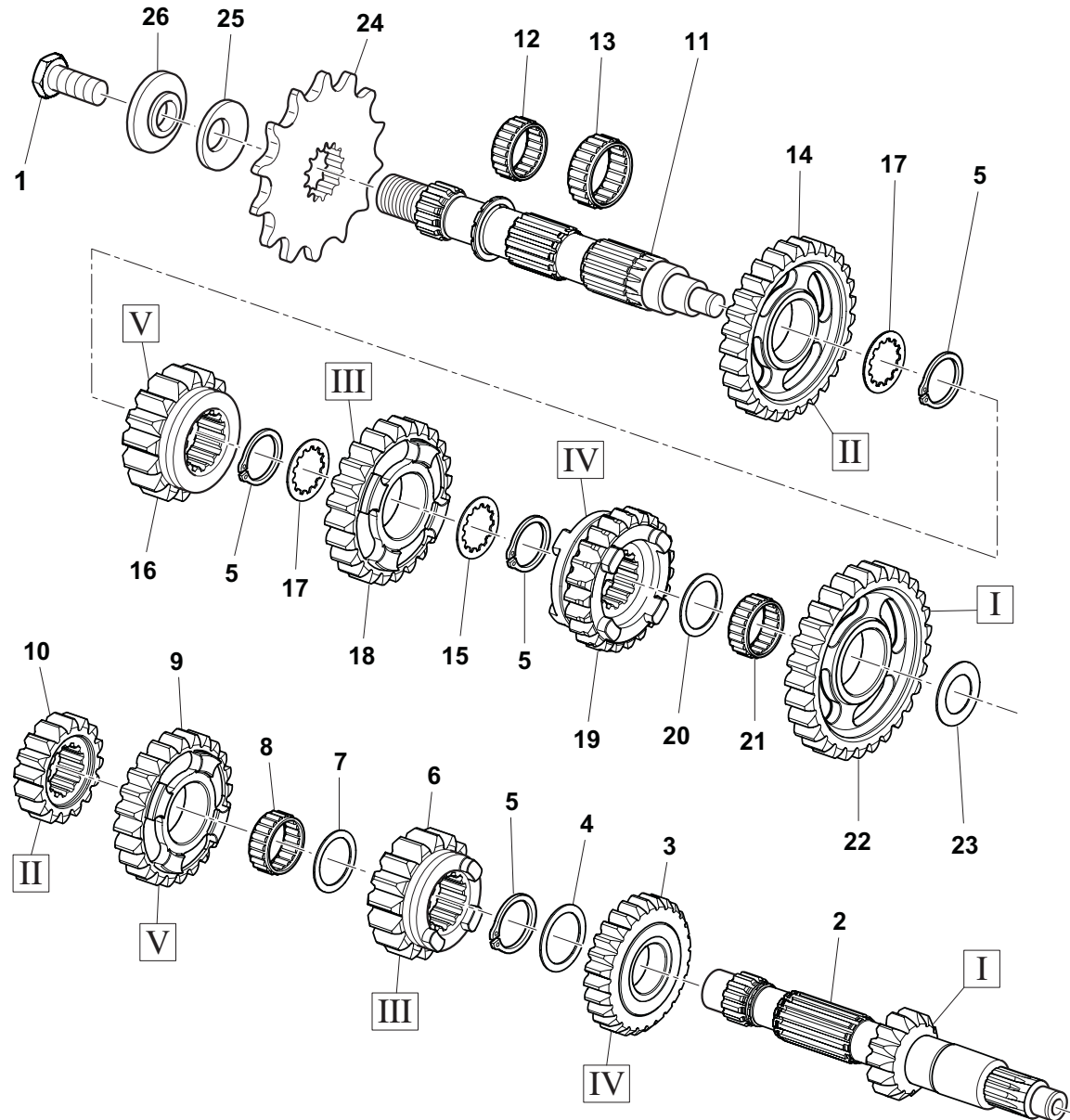

TR 650 Terra/2013
TR 650 Strada/2013

TAVOLA - DRAWING
TABLE - BILD - TABLA

23

CAMBIO - GEARBOX
BOITE DE VITESSE - GANGSCHALTUNG
CAMBIO



Note Notes Notes Marke Notas	Pos. No. N. Index Pos.	N. Cod. Code No. Nr. Code Code Nr N. Cod.	Q.tà Q.ty Q.te M.ge C.ad	DENOMINAZIONE	NAME	DESIGNATION	BESHREIBUNG	DENOMINACION
M10X35	1	7700403	1	Vite	Screw	Vis	Schraube	Tornillo
Z=12	2	7700267	1	Albero primario	Input shaft	Arbre primaire	Hauptantriebswelle	Árbol primario
Z=22	3	7700147	1	Ingranaggio	Gear	Engrenage	Zahnrad	Engranaje
Ø25,6xØ28,5x1,5	4	7700155	1	Rasamento	Adjustament shim	Epaisseurs	Ausgleichsscheiben	distanciadora
	5	7700156	4	Anello di fermo	Retaining ring	Bague d'arrêt	Sicherungsring	Anillo de retención
Z=16	6	7700151	1	Ingranaggio	Gear	Engrenage	Zahnrad	Engranaje
Ø21,2xØ27,5x1	7	7700157	1	Rasamento	Adjustament shim	Epaisseurs	Ausgleichsscheiben	distanciadora
	8	7700158	1	Gabbia a rullini	Needle cage	Cage à aiguilles	Nadelkäfig	Jaula de rodillos
Z=24	9	7700148	1	Ingranaggio	Gear	Engrenage	Zahnrad	Engranaje
Z=16	10	7700145	1	Ingranaggio	Gear	Engrenage	Zahnrad	Engranaje
	11	7700269	1	Albero secondario	Output shaft	Arbre secondaire	Vorgelegewelle	Eje secundario
Ø22xØ26x10	12	7700163	1	Gabbia a rullini	Needle cage	Cage à aiguilles	Nadelkäfig	Jaula de rodillos
Ø22xØ26x13	13	7700162	1	Gabbia a rullini	Needle cage	Cage à aiguilles	Nadelkäfig	Jaula de rodillos
Z=28	14	7700150	1	Ingranaggio	Gear	Engrenage	Zahnrad	Engranaje
	15	7700329	1	Rosetta scanalata	Splined washer	Rondelle rainurée	Gerillte Unterlegscheibe	Arandela ranurada
Z=21	16	7700152	1	Ingranaggio	Gear	Engrenage	Zahnrad	Engranaje
	17	7700179	2	Rosetta scanalata	Splined washer	Rondelle rainurée	Gerillte Unterlegscheibe	Arandela ranurada
Z=21	18	7700146	1	Ingranaggio	Gear	Engrenage	Zahnrad	Engranaje
Z=23	19	7700153	1	Ingranaggio	Gear	Engrenage	Zahnrad	Engranaje
Ø21,2xØ30x1	20	7700161	1	Rasamento	Adjustament shim	Epaisseurs	Ausgleichsscheiben	distanciadora
Ø21xØ25x10	21	7700160	1	Gabbia a rullini	Needle cage	Cage à aiguilles	Nadelkäfig	Jaula de rodillos
Z=33	22	7700149	1	Ingranaggio	Gear	Engrenage	Zahnrad	Engranaje
Ø17,2xØ30x1	23	7700159	1	Rasamento	Adjustament shim	Epaisseurs	Ausgleichsscheiben	distanciadora
Z=16	24	7700154	1	Pignone	Sprocket	Pignon	Ritzel	Piñón
Ø34xØ16,3x1,5	25	7700398	1	Rondella bombata	Ball washer	Rondelle	Federscheibe	Arandela
	26	7700296	1	Anello a gradino	Step ring	Bague d'arrêt	Sicherungsring	Anillo de retención

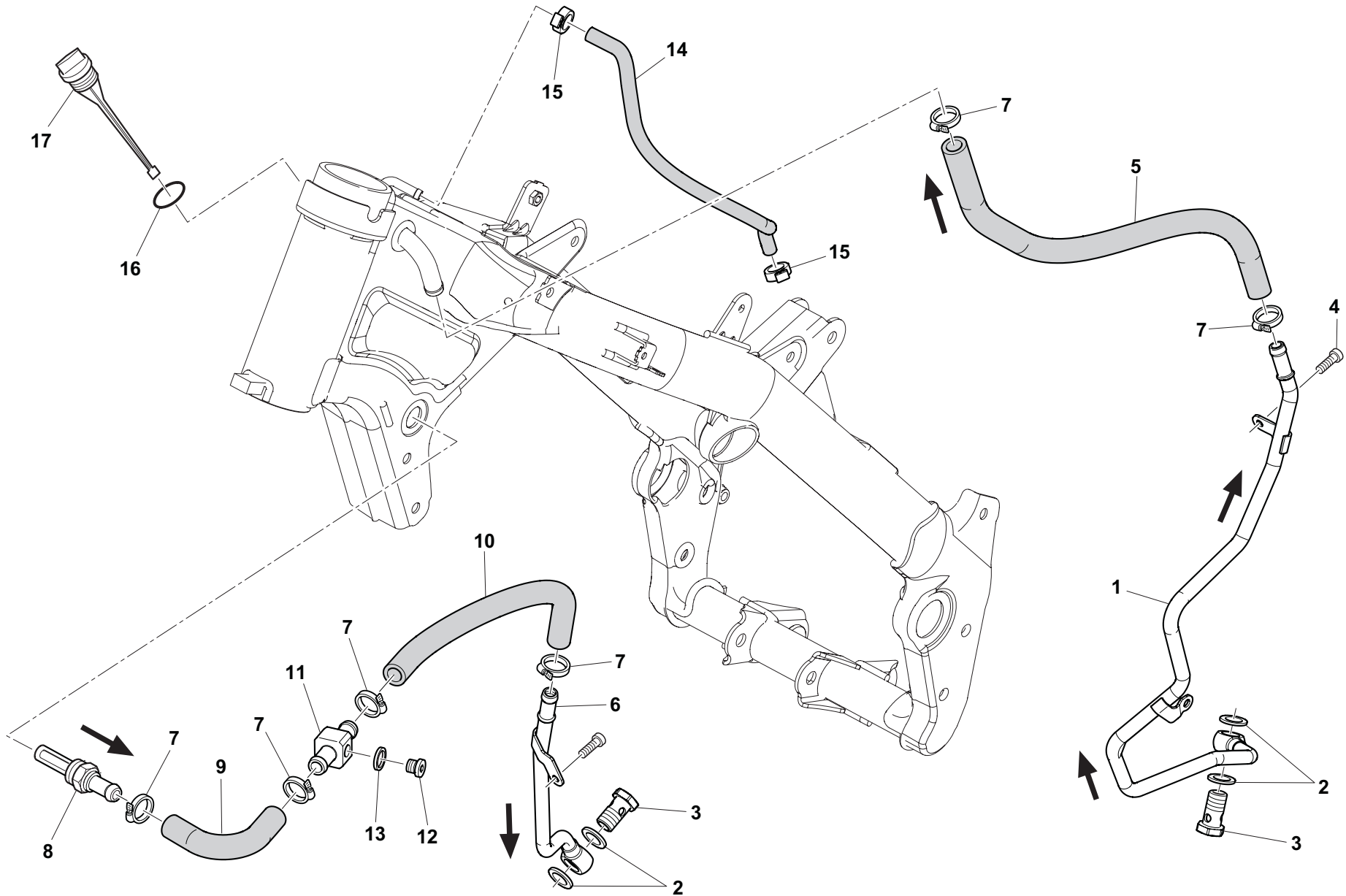

TR 650 Terra/2013
TR 650 Strada/2013

TAVOLA - DRAWING
 TABLE - BILD - TABLA

24

CIRCUITO OLIO - OIL SYSTEM
SYSTÈME D'HUILE - ÖLSYSTEM
SISTEMA DE ACEITE



Note Notes Notes Marke Notas	Pos. No. Index Pos.	N. Cod. Code No. Nr. Code Code Nr N. Cod.	Q.tà Q.ty Q.te M.ge C.ad	DENOMINAZIONE	NAME	DESIGNATION	BESHREIBUNG	DENOMINACION
	1	8000H6521	1	Tubo mandata olio	Oil delivery pipe	Tuyau de refoulement huile	Ölzufuhrrohr	Tubo alimentación aceite
	2	9963276	4	Guarnizione	Gasket	Joint	Dichtung	Junta
M16x1,5x28	3	7707506	2	Vite forata	Screw	Vis	Schraube	Boca
M6x12	4	7651203	1	Vite	Screw	Vis	Schraube	Tornillo
	5	8000H6522	1	Tubo mandata olio	Oil delivery pipe	Tuyau de refoulement huile	Ölzufuhrrohr	Tubo alimentación aceite
	6	8000H6807	1	Tubo ritorno olio	Oil back-flow pipe	Tuyau d'huile	Ölrohr	Tubo aceite
	7	800099475	6	Fascetta	Clamp	Collier	Schelle	Abrazadera
	8	8000H7046	1	Filtro olio a telaio	Oil filter	Filtre à huile	Ölfilter	Filtro aceite
	9	8539159	1	Tubo ritorno olio	Oil back-flow pipe	Tuyau d'huile	Ölrohr	Tubo aceite
	10	8A00H6522	1	Tubo olio	Oil pipe	Tuyau d'huile	Ölrohr	Tubo aceite
	11	8538989	1	Raccordo	Union	Raccord	Anschluss	Racor
	12	9904393	1	Tappo	Plug	Bouchon	Stopfen	Tapón
	13	8539140	1	Rosetta	Washer	Rondelle	Unterlegscheibe	Arandela
0,43 m	14	947200072	1	Tubo telato	Pipe	Tube	Rohr	Tubo
	15	800067610	2	Fascetta	Clamp	Collier	Schelle	Abrazadera
	16	8539573	1	Anello OR	O-ring	Joint torique	O-Ring	Junta tórica
	17	8000H6740	1	Tappo asta livello olio	Oil level dipstick plug	Bouchon tige niveau d'huile	Stopfen Ölmesstab	Tapón varilla nivel aceite

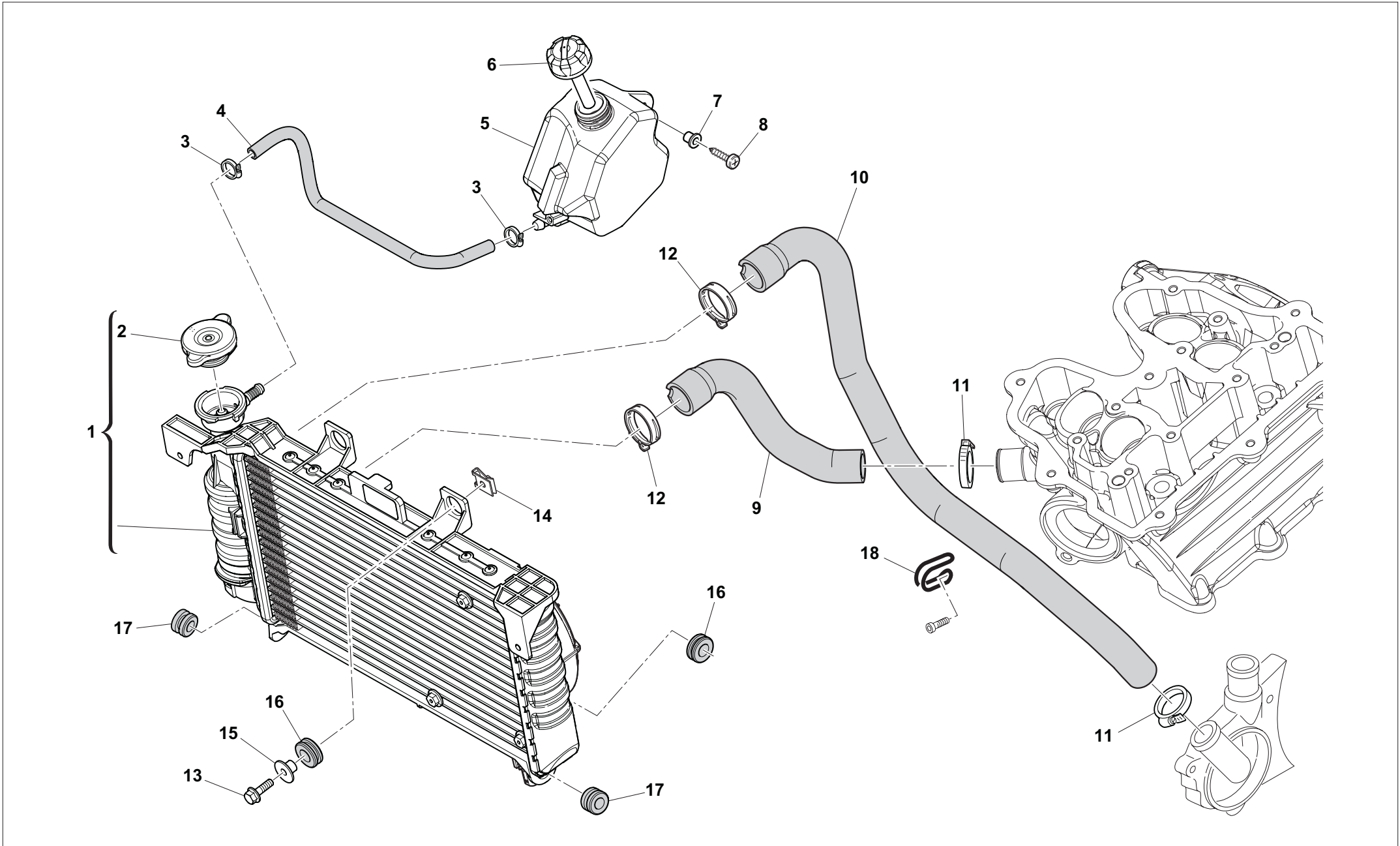

TR 650 Terra/2013
 TR 650 Strada/2013

TAVOLA - DRAWING
 TABLE - BILD - TABLA

25

IMPIANTO DI RAFFREDDAMENTO - COOLING SYSTEM
INSTALLATION RAFROIDISSEMENT - SCHMIERUNGSSYSTEM
EQUIPO DE ENFRIAMENTO



Note Notes Notas Marke Notas	Pos. No. N. Index Pos.	N. Cod. Code No. Nr. Code Code Nr N. Cod.	Q.tà Q.ty Q.te M.ge C.ad	DENOMINAZIONE	NAME	DESIGNATION	BESHREIBUNG	DENOMINACION
	1	8000H5220	1	Radiatore con tappo	Radiator with cap	Radiateur avec bouchon	Kühler	Radiador con tapón
	2	7695769	1	Tappo	Plug	Bouchon	Stopfen	Tapón
	3	800056462	2	Fascetta	Clamp	Collier	Schelle	Abrazadera
0,4 m	4	947200019	1	Tubo	Pipe	Tube	Rohr	Tubo
	5	8000H5221	1	Serbatoio espansione	Expansion tank	Réservoir d'expansion	Ausdehnungsgefäß	Depósito expansión
	6	7672750	1	Tappo	Plug	Bouchon	Stopfen	Tapón
	7	Z00069429	1	Bussola	Bushing	Douille	Buchse	Casquillo
	8	9904424	1	Vite autofilettante	Self-tapping screw	Vis autotaraudeuse	Blechschraube	Tornillo autorroscante
	9	8000H5218	1	Tubo mandata	Delivery pipe	Tuyau de refoulement	Vorlaufrohr	Tubo alimentación
	10	8000H5219	1	Tubo inferiore	Lower pipe	Tuyau inférieur	Rohr unten	Tubo inferior
	11	7696320	2	Fascetta	Clamp	Collier	Schelle	Abrazadera
	12	8B0099475	2	Fascetta HOP	Clamp	Collier	Schelle	Abrazadera
M6x25	13	8539442	2	Vite TE	Hexalobular screw	Vis TE	SK Schraube	Tornillo TE
	14	U00046893	2	Dado a graffetta	Clip nut	Ecrou à agrafe	Sicherungsmutter	Tuerca de clip
	15	800059802	2	Bussola	Bushing	Douille	Buchse	Casquillo
	16	800059803	3	Gommino	Rubber ring	Joint en caoutchouc	Gummischeibe	Goma
	17	800033288	2	Antivibrante	Silent-block	Antivibration	Dämpfer	Anti-vibrador
	18	8000A1792	1	Fascetta	Clamp	Collier	Schelle	Abrazadera

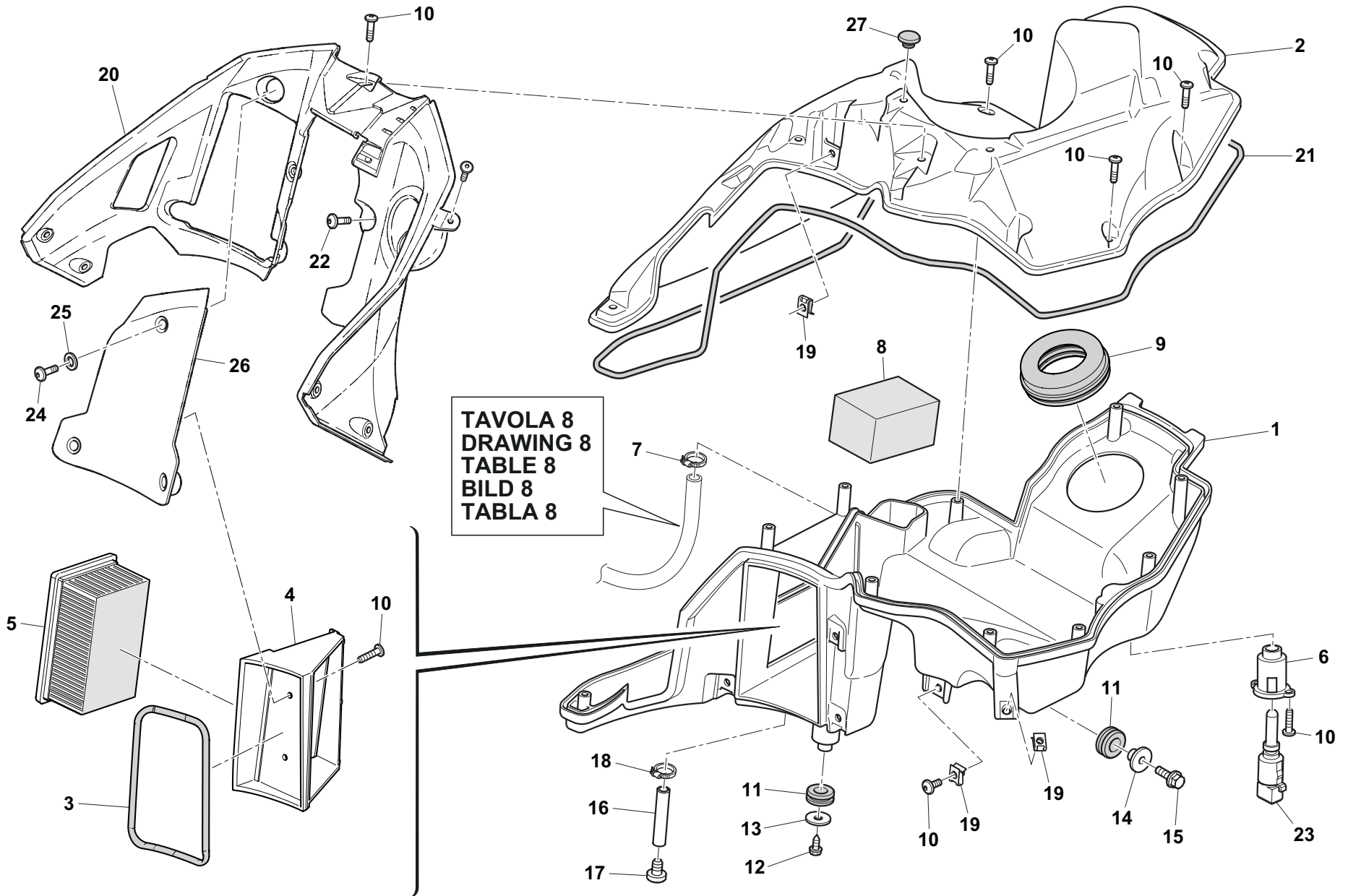

TR 650 Terra/2013
TR 650 Strada/2013

TAVOLA - DRAWING
TABLE - BILD - TABLA

26

CASSA FILTRO - AIR BOX
BOITE FILTRE - FILTERKASTEN
CAJA FILTRO AIRE



Note Notes Notes Marke Notas	Pos. No. N. Index Pos.	N. Cod. Code No. Nr. Code Code Nr N. Cod.	Q.tà Q.ty Q.te M.ge C.ad	DENOMINAZIONE	NAME	DESIGNATION	BESHREIBUNG	DENOMINACION
	1	8000H6452	1	Base scatola filtro	Filter box base	Base boîtier du filtre	Boden Filtergehäuse	Base caja filtro
	2	8000H6453	1	Coperchio scatola filtro	Filter box cover	Couvercle boîtier du filtre	Deckel Filtergehäuse	Tapa caja filtro
	3	8000H7718	1	Guarnizione	Gasket	Joint	Dichtung	Junta
	4	8000H6455	1	Cassetto filtro aria	Air filter box	Boîtier de filtre à air	Luftfiltergehäuse	Caja filtro aire
	5	8539189	1	Filtro aria	Air filter	Filtre à air	Luftfilter	Filtro aire
	6	8538731	1	Supporto	Support	Support	Halterung	Soporte
	7	9952104	1	Fascetta	Clamp	Collier	Schelle	Abrazadera
	8	8000H6813	1	Spugna	Foam	Eponge	Schaumstoffring	Gomaespuma
	9	8000H6810	1	Manicotto	Coupling	Manchon	Muffe	Manguito
5x12	10	9904424	14	Vite autofilettante	Self-tapping screw	Vis autotaraudeuse	Blechschraube	Tornillo autorroscante
	11	800059803	2	Gommino	Rubber ring	Joint en caoutchouc	Gummischeibe	Goma
	12	9905798	1	Vite autofilettante	Self-tapping screw	Vis autotaraudeuse	Blechschraube	Tornillo autorroscante
	13	Z00059801	1	Rosetta	Washer	Rondelle	Unterlegscheibe	Arandela
	14	800059802	1	Bussola	Bushing	Douille	Buchse	Casquillo
	15	9907146	1	Vite	Screw	Vis	Schraube	Tornillo
7x10	16	947200010	1	Tubo	Pipe	Tube	Rohr	Tubo
	17	8000H6863	2	Tappo	Plug	Bouchon	Stopfen	Tapón
	18	80A042349	2	Fascetta	Clamp	Collier	Schelle	Abrazadera
	19	7651465	12	Dado a graffetta	Clip nut	Ecrou à agrafe	Sicherungsmutter	Tuerca de clip
	20	8000H7441	1	Chiusura anteriore centrale	Front central locking	Fermeture avant central	Vorderer zentraler Verschluss	Cierre delantero central
	21	8000H7717	1	Guarnizione	Gasket	Joint	Dichtung	Junta
M5x14	22	8539451	2	Vite	Screw	Vis	Schraube	Tornillo
	23	1739510	1	Sensore temperatura aria	Air temperature sensor	Capteur de température air	Lufttemperatursensor	Sensor temperatura aire
M5x14	24	8539450	3	Vite TCEI	Allen screw	Vis TCEI	Zyl. Schraube	Tornillo TCEI
	25	Z00036137	3	Rosetta	Washer	Rondelle	Unterlegscheibe	Arandela
	26	8000H6454	1	Chiusura anteriore	Cover	Couvercle	Deckel	Tapa
	27	800045042	2	Gommino	Rubber ring	Joint en caoutchouc	Gummischeibe	Goma

TAVOLA 48
DRAWING 48
TABLE 48
BILD 48
TABLA 48



TAVOLA 16
DRAWING 16
TABLE 16
BILD 16
TABLA 16

TR 650 Terra/2013
TR 650 Strada/2013

TAVOLA - DRAWING
TABLE - BILD - TABLA

27

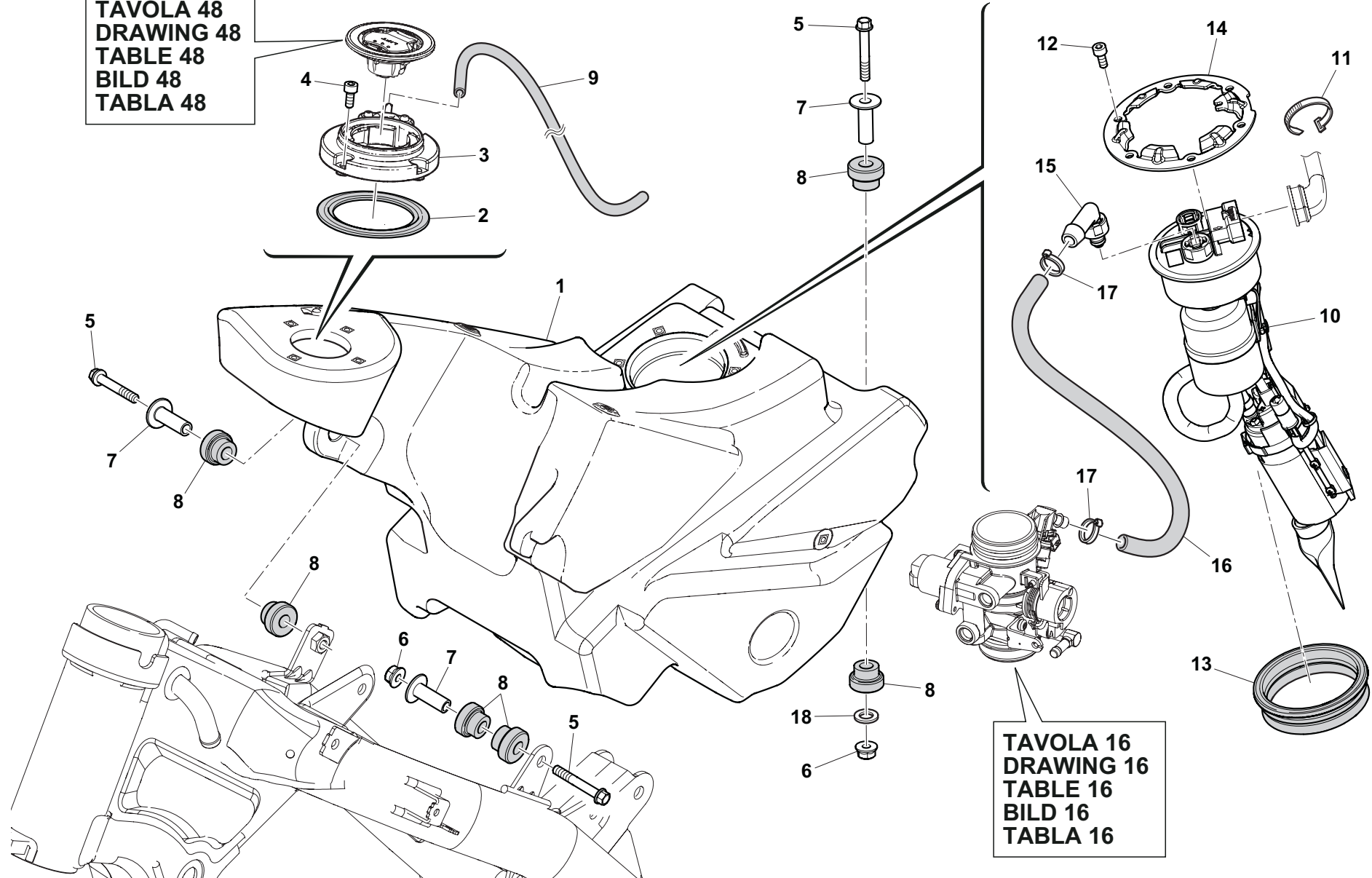
SERBATOIO CARBURANTE - FUEL TANK
RESERVOIR CARBURANT - KRAFTSTOFFBEHALTER
DEPOSITO GASOLINA



Note Notes Notes Marke Notas	Pos. No. Index Pos.	N. Cod. Code No. Nr. Code Code Nr N. Cod.	Q.tà Q.ty Q.te M.ge C.ad	DENOMINAZIONE	NAME	DESIGNATION	BESHREIBUNG	DENOMINACION
	1	8000H5306	1	Serbatoio carburante	Fuel tank	Réservoir de carburant	Kraftstofftank	Depósito combustible
USA	1	8538806	1	Serbatoio carburante	Fuel tank	Réservoir de carburant	Kraftstofftank	Depósito combustible
	2	8000H7041	1	Guarnizione	Gasket	Joint	Dichtung	Junta
	3	8539045	1	Ghiera tappo carburante	Fuel cap ring nut	Bague bouchon carburant	Gewinding Tankdeckel	Tuerca anular tapón combustible
M5x14	4	Z00065535	4	Vite TCEI	Allen screw	Vis TCEI	Zyl. Schraube	Tornillo TCEI
M6x45	5	6973219	4	Vite	Screw	Vis	Schraube	Tornillo
	6	Z00044240	3	Dado	Nut	Écrou	Mutter	Tuerca
	7	8A00H4654	4	Distanziale	Spacer	Entretoise	Abstandhalter	Distanciador
	8	8539436	8	Gommino	Rubber ring	Joint en caoutchouc	Gummischeibe	Goma
0,6 m	9	947200035	1	Tubo	Pipe	Tube	Rohr	Tubo
	10	8000H5311	1	Pompa benzina	Fuel pump	Pompe à carburant	Benzinpumpe	Bomba gasolina
	11	800056444	2	Fascetta	Clamp	Collier	Schelle	Abrazadera
M5x12	12	8000H7766	6	Vite	Screw	Vis	Schraube	Tornillo
	13	7725353	1	Guarnizione	Gasket	Joint	Dichtung	Junta
	14	7725332	1	Ghiera	Ring nut	Bague	Gewinding	Tuerca anular
	15	8000H5309	1	Raccordo	Union	Raccord	Anschluss	Racor
0,33 m	16	947200074	1	Tubo mandata	Delivery pipe	Tuyau de refoulement	Vorlaufrohr	Tubo alimentación
	17	8000H1981	2	Fascetta	Clamp	Collier	Schelle	Abrazadera
	18	8538769	2	Rosetta	Washer	Rondelle	Unterlegscheibe	Arandela

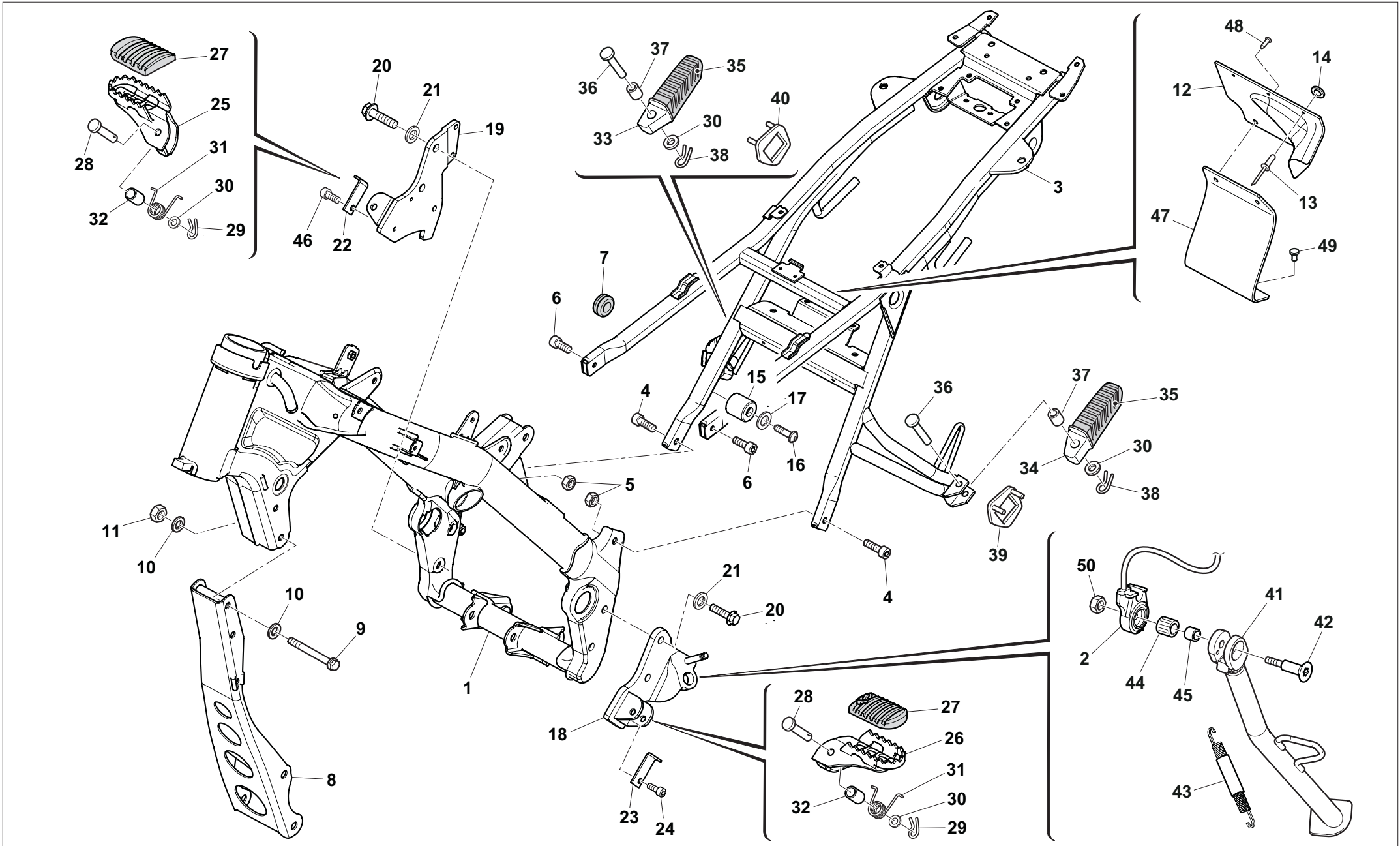

TR 650 Terra/2013
TR 650 Strada/2013

TAVOLA - DRAWING
TABLE - BILD - TABLA

28

TELAIO 1/2 - FRAME 1/2
CADRE 1/2 - RAHMEN 1/2
BASTIDOR 1/2



Note Notes Notes Marke Notas	Pos. No. Index Pos.	N. Cod. Code No. Nr. Code Code Nr N. Cod.	Q.tà Q.ty Q.te M.ge C.ad	DENOMINAZIONE	NAME	DESIGNATION	BESHREIBUNG	DENOMINACION
	1	8000H5766	1	Telaio anteriore	Front chassis	Châssis avant	Vorderer Rahmen	Chasis delantero
	2	8526970	1	Sensore gamba laterale	Side leg switch	Interrupteur branche latérale	Sensor	Interruptor pata lateral
	3	8000H5782	1	Telaio posteriore	Rear chassis	Châssis arrière	Hinterer Rahmen	Chasis trasero
M8x25	4	8539175	2	Vite TC/Torx	Allen/Torx screw	Vis TC/Torx	Zyl./Torx Schraube	Tornillo TC/Torx
	5	9905977	2	Dado	Nut	Écrou	Mutter	Tuerca
M8x16	6	8539138	2	Vite TC/Torx	Allen/Torx screw	Vis TC/Torx	Zyl./Torx Schraube	Tornillo TC/Torx
	7	8000H3613	1	Gommino	Rubber ring	Joint en caoutchouc	Gummischeibe	Goma
	8	8000H6864	1	Supporto motore	Enine support	Support moteur	Halterung	Soporte motor
M8x75	9	9906028	2	Vite TE	Hexalobular screw	Vis TE	SK Schraube	Tornillo TE
	10	9905733	4	Rosetta	Washer	Rondelle	Unterlegscheibe	Arandela
	11	9904877	2	Dado	Nut	Écrou	Mutter	Tuerca
	12	8538454	1	Protezione serbatoio	Fuel tank protection	Protection	Schutz	Protección
	13	8000H7655	3	Rivetto	Rivet	Rivet	Niet	Remache
	14	62ND15547	3	Rosetta	Washer	Rondelle	Unterlegscheibe	Arandela
	15	800056800	1	Rullo catena	Chain roller	Galet de chaîne	Kettenrolle	Rodillo cadena
M6x12	16	7694305	1	Vite	Screw	Vis	Schraube	Tornillo
	17	8538769	1	Rosetta	Washer	Rondelle	Unterlegscheibe	Arandela
	18	8000H6239	1	Supporto pedana Sx	LH footrest support	Support repose-pieds G	Halterung Fußraste li	Soporte estribo izq.
	19	8000H6238	1	Supporto pedana Dx	RH footrest support	Support repose-pieds D	Halterung Fußraste re	Soporte estribo dch.
M10x40	20	8539443	4	Vite Torx	Torx screw	Vis Torx	Torx Schraube	Tornillo Torx
	21	9904607	4	Rosetta	Washer	Rondelle	Unterlegscheibe	Arandela
	22	8000H7685	1	Piastrina di fermo	Retaining plate	Plaquette d'arrêt	Halteplättchen	Placa de fijación
	23	8A00H7685	1	Piastrina di fermo	Retaining plate	Plaquette d'arrêt	Halteplättchen	Placa de fijación
	24	9905536	2	Vite	Screw	Vis	Schraube	Tornillo
	25	7701200	1	Pedana destra	RH footrest	Repose-pieds droit	Fußraste rechts	Estribo derecho
	26	7701199	1	Pedana sinistra	LH footrest	Repose-pieds gauche	Fußraste links	Estribo izquierdo
	27	7712957	2	Gommino	Rubber ring	Joint en caoutchouc	Gummischeibe	Goma
	28	7717832	2	Perno	Pin	Axe	Bolzen	Eje
	29	64ND20048	2	Copiglia	Split pin	Goupille	Splint	Pasador
	30	9905733	4	Rosetta	Washer	Rondelle	Unterlegscheibe	Arandela
	31	8000H7447	2	Molla	Spring	Ressort	Feder	Muelle
	32	1242019	2	Distanziale	Spacer	Entretoise	Abstandhalter	Distanciator
	33	2310404	1	Pedana destra	RH footrest	Repose-pieds droit	Fußraste rechts	Estribo derecho

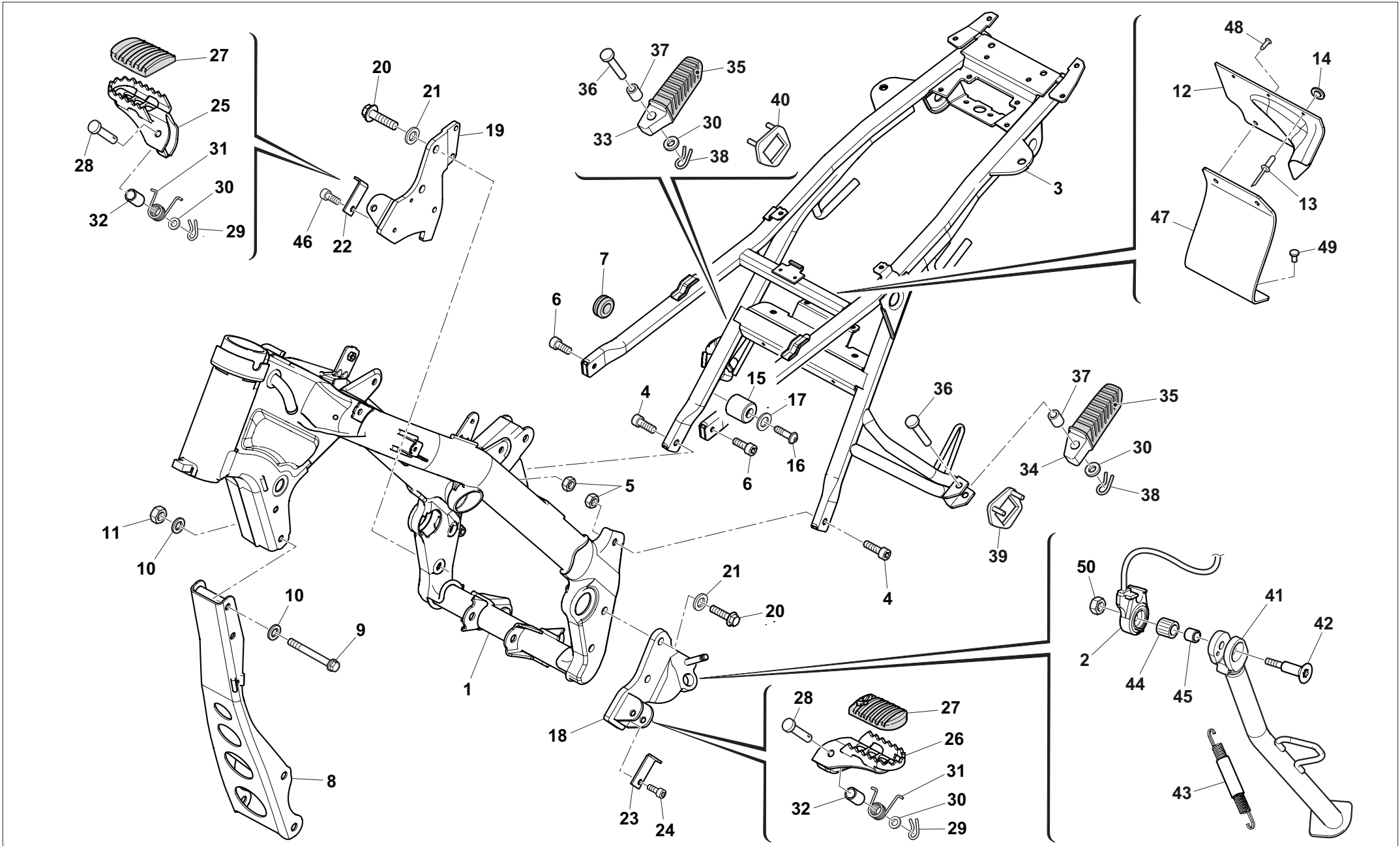

TR 650 Terra/2013
TR 650 Strada/2013

TAVOLA - DRAWING
TABLE - BILD - TABLA

28

TELAIO 1/2 - FRAME 1/2
CADRE 1/2 - RAHMEN 1/2
BASTIDOR 1/2



Note Notes Notes Marke Notas	Pos. No. Index Pos.	N. Cod. Code No. Nr. Code Code Nr N. Cod.	Q.tà Q.ty Q.te M.ge C.ad	DENOMINAZIONE	NAME	DESIGNATION	BESHREIBUNG	DENOMINACION
	34	2310403	1	Pedana sinistra	LH footrest	Repose-pieds gauche	Fußraste links	Estribo izquierdo
	35	2310401	2	Gommino	Rubber ring	Joint en caoutchouc	Gummischeibe	Goma
	36	7717831	2	Perno	Pin	Axe	Bolzen	Eje
	37	8000A6638	2	Distanziale	Spacer	Entretoise	Abstandhalter	Distanciador
	38	64ND20048	2	Copiglia	Split pin	Goupille	Splint	Pasador
	39	7687107	1	Piastrina	Plate	Plaquette	Plättchen	Placa
	40	7687108	1	Piastrina	Plate	Plaquette	Plättchen	Placa
	41	8538471	1	Gamba laterale	Side leg	Branche latérale	Federbein seitlich	Pata lateral
	42	7719788	1	Vite	Screw	Vis	Schraube	Tornillo
	43	7715118	1	Molla	Spring	Ressort	Feder	Muelle
	44	7678011	1	Bussola	Bushing	Douille	Buchse	Casquillo
	45	7678010	1	Bronzina	Bearing	Bague	Gleitlager	Buje
	46	9907146	1	Vite	Screw	Vis	Schraube	Tornillo
	47	8538453	1	Protezione ammortizzatore	Shock absorber protection	Protection amortisseur	Schutz Stoßdämpfer	Protección amortiguador
	48	8353567	3	Rivetto	Rivet	Rivet	Niet	Remache
	49	8538794	2	Rivetto	Rivet	Rivet	Niet	Remache
	50	9902745	1	Dado	Nut	Écrou	Mutter	Tuerca



TAVOLA 45
DRAWING 45
TABLE 45
BILD 45
TABLA 45

TR 650 Terra/2013
TR 650 Strada/2013

TAVOLA - DRAWING
TABLE - BILD - TABLA

29

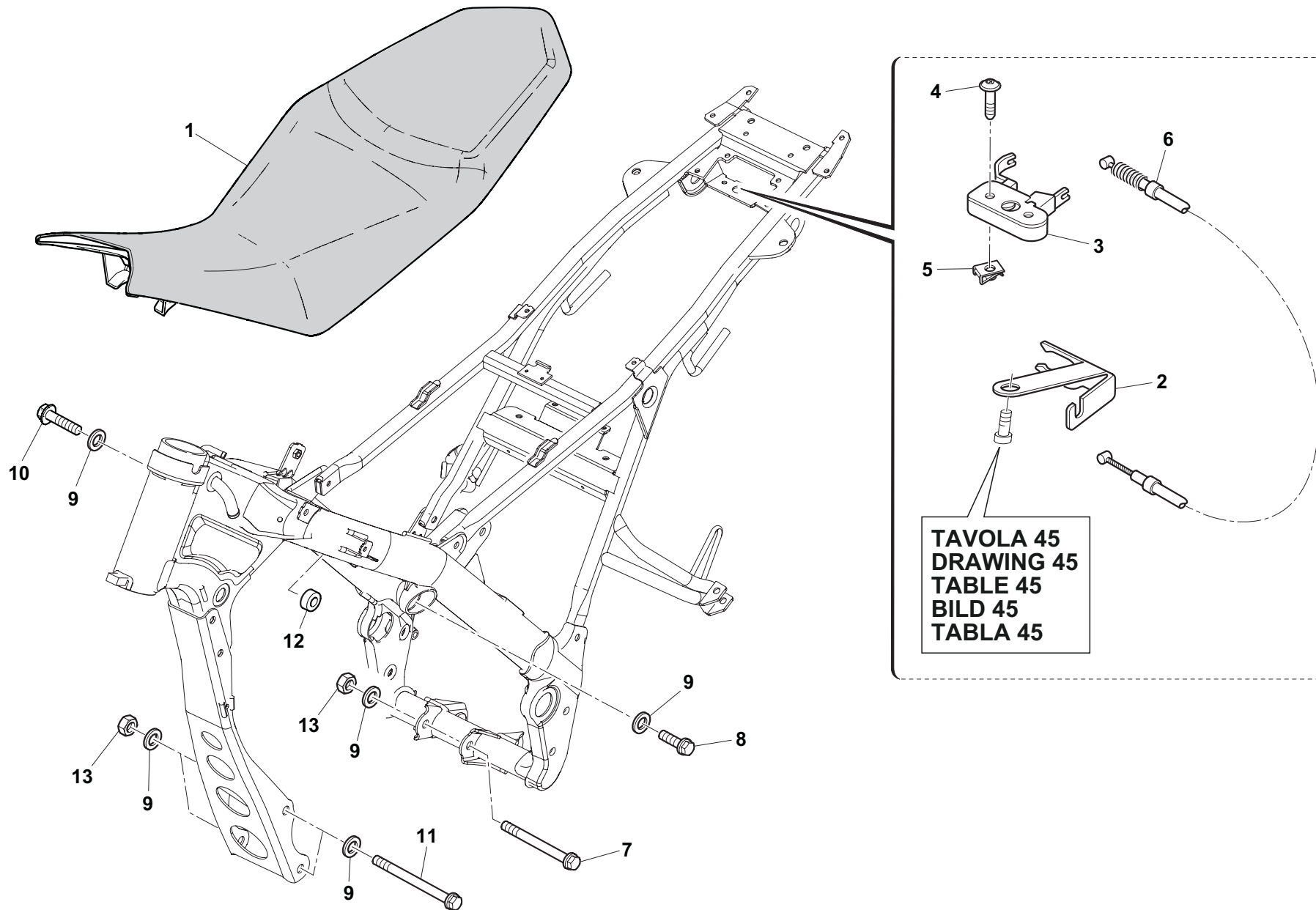
TELAIO 2/2 - FRAME 2/2
CADRE 2/2 - RAHMEN 2/2
BASTIDOR 2/2



Note Notes Notes Marke Notas	Pos. No. Index Pos.	N. Cod. Code No. Nr. Code Code Nr N. Cod.	Q.tà Q.ty Q.te M.ge C.ad	DENOMINAZIONE	NAME	DESIGNATION	BESHREIBUNG	DENOMINACION
	1	8000H5339	1	Sella	Saddle	Selle	Sitzbank	Asiento
	2	8000H7826	1	Piastra serratura sella	Saddle lock plate	Plaque serrure selle	Sitzbankschloss Platte	Placa cerradura asiento
	3	8000H2127	1	Serratura sella	Saddle lock	Serrure selle	Sitzbankschloss	Cerradura asiento
M6x25	4	8539486	2	Vite TSPEI	Screw	Vis	Schraube	Tornillo
	5	U00046893	2	Dado a graffetta	Clip nut	Ecrou à agrafe	Sicherungsmutter	Tuerca de clip
	6	8539043	1	Cavo flessibile	Cable	Câble	Kabel	Cable
M10x90	7	9905622	1	Vite	Screw	Vis	Schraube	Tornillo
M10x30	8	8539449	1	Vite TC/Torx	Allen/Torx screw	Vis TC/Torx	Zyl./Torx Schraube	Tornillo TC/Torx
	9	9904607	6	Rosetta	Washer	Rondelle	Unterlegscheibe	Arandela
M10x40	10	9903801	1	Vite	Screw	Vis	Schraube	Tornillo
M10x110	11	8538788	2	Vite	Screw	Vis	Schraube	Tornillo
10 mm	12	8000H7716	1	Distanziale (bianco)	Spacer (white)	Entretoise (blanc)	Abstandhalter (weiß)	Distanciadador (blanco)
11 mm	12	8A00H7716	1	Distanziale (nero)	Spacer (black)	Entretoise (noir)	Abstandhalter (schwarz)	Distanciadador (negro)
M10	13	6760587	3	Dado	Nut	Écrou	Mutter	Tuerca

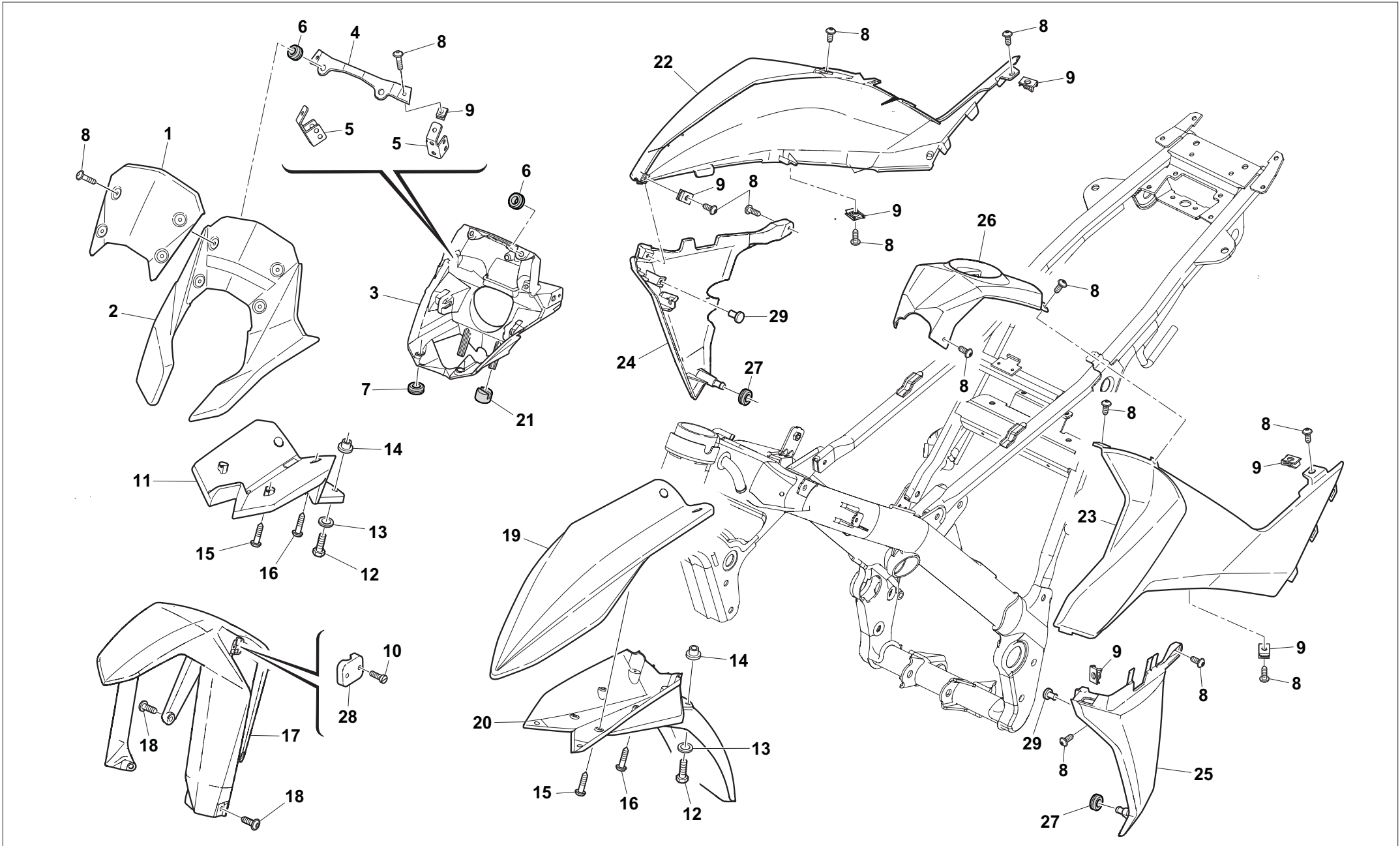

TR 650 Terra/2013
TR 650 Strada/2013

TAVOLA - DRAWING
TABLE - BILD - TABLA

30

PANNELLI, PARAFANGHI ANTERIORI - FRONT PANEL, FENDERS
PANNEAU, GARDE-BOUES AVANT - STREIFEN, KOTFLUGEL, SATTEL VORDER
PANELO, GUARDABARROS DELANTERO



Note Notes Notes Marke Notas	Pos. N. Index Pos.	N. Cod. Code No. Nr. Code Code Nr N. Cod.	Q.tà Q.ty Q.te M.ge C.ad	DENOMINAZIONE	NAME	DESIGNATION	BESHREIBUNG	DENOMINACION
	1	8000H7630	1	Tegolino	Front fairing	Nez de carénage	Windschutzscheibe	Cúpula
	2	8000H5312	1	Cupolino	Front fairing	Nez de carénage	Windschutzscheibe	Cúpula
	3	8000H6782	1	Supporto	Support	Support	Halterung	Soporte
	4	8000H7688	1	Staffa	Bracket	Etrier	Bügel	Estribo
	5	8538478	2	Piastrina	Plate	Plaquette	Plättchen	Placa
	6	2347012	4	Gommino	Rubber ring	Joint en caoutchouc	Gummischeibe	Goma
	7	8000H3250	2	Gommino	Rubber ring	Joint en caoutchouc	Gummischeibe	Goma
	8	8539451	16	Vite	Screw	Vis	Schraube	Tornillo
	9	7651465	10	Dado a graffetta	Clip nut	Ecrou à agrafe	Sicherungsmutter	Tuerca de clip
Strada	10	ZA0084658	2	Vite	Screw	Vis	Schraube	Tornillo
Strada	11	8000H6786	1	Rinforzo per parafango	Mudguard reinforcement	Renfort pour garde-boue	Verstärkung für Kotflügel	Refuerzo para guardabarros
M6x20	12	9903806	4	Vite TE	Hexalobular screw	Vis TE	SK Schraube	Tornillo TE
	13	9904427	4	Rosetta	Washer	Rondelle	Unterlegscheibe	Arandela
Ø9xØ7x9,5	14	ZC0069429	4	Bussola	Bushing	Douille	Buchse	Casquillo
M5x12	15	8538774	2	Vite autofilettante	Self-tapping screw	Vis autotaraudeuse	Blechschaube	Tornillo autorroscante
M5x25	16	9907239	2	Vite autofilettante	Self-tapping screw	Vis autotaraudeuse	Blechschaube	Tornillo autorroscante
Strada	17	8000H6788	1	Parafango anteriore	Front mudguard	Garde-boue avant	Vorderradkotflügel	Guardabarros delantero
Strada	18	8539335	6	Vite TE/Torx flangiata	Hex./Torx flanged screw	Vis de bride TE/Torx	SK/Torx-Bundschraube	Perno de reborde TE/Torx
Terra	19	8000H5008	1	Puntale parafango anteriore	Front mudguard pushrod	Embout garde-boue avant	Stösselschaft Vorderradkotflügel	Punta guardabarros delantero
Terra	20	8000H3858	1	Coda parafango anteriore	Front mudguard tail	Queue garde-boue avant	Endstück Vorderradkotflügel	Cola guardabarros delantero
Terra	21	8539456	2	Gommino	Rubber ring	Joint en caoutchouc	Gummischeibe	Goma
Terra	22	8000H5313	1	Convogliatore Dx	RH scoop	Défecteur D	Luftleitblech re	Deflector dch.
Strada	22	8539029	1	Convogliatore Dx	RH scoop	Défecteur D	Luftleitblech re	Deflector dch.
Terra	23	8000H5314	1	Convogliatore Sx	LH scoop	Défecteur G	Luftleitblech li	Deflector izq.
Strada	23	8539030	1	Convogliatore Sx	LH scoop	Défecteur G	Luftleitblech li	Deflector izq.
	24	8000H6784	1	Protezione Dx	RH protection	Protection D	Schutz re	Protección dch.
	25	8000H6785	1	Protezione Sx	LH protection	Protection G	Schutz li	Protección izq.
	26	8000H6783	1	Coperchio	Cover	Couvercle	Deckel	Tapa
	27	800033288	2	Antivibrante	Silent-block	Antivibration	Dämpfer	Anti-vibrador
Strada	28	80C0A0633	1	Fermacavo	Cable retainer	Passe-câble	Kabeldurchführung	Pasacable
	29	8538794	2	Rivetto	Rivet	Rivet	Niet	Remache

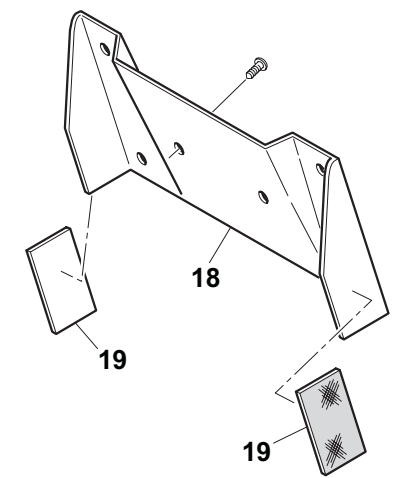
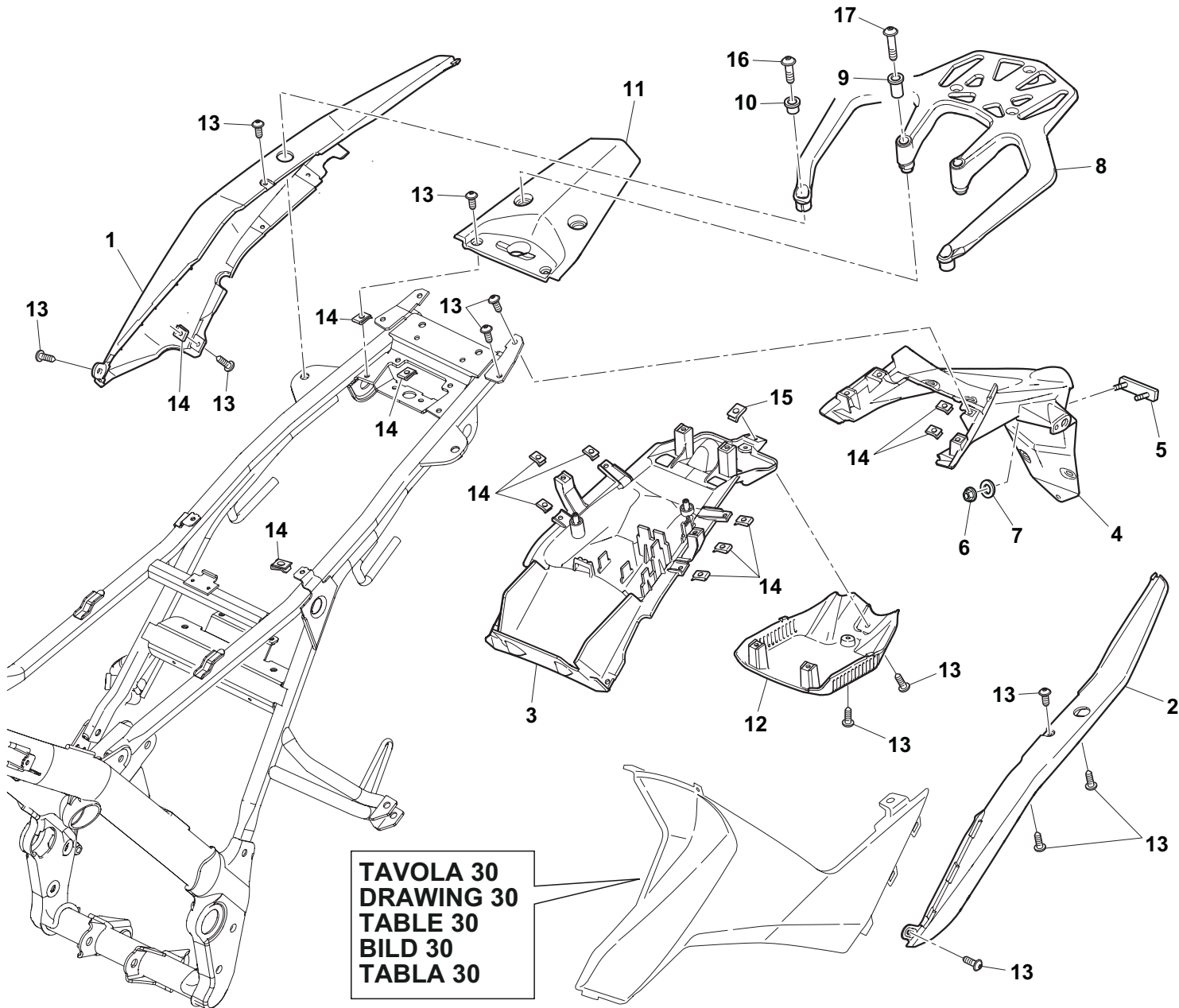

USA

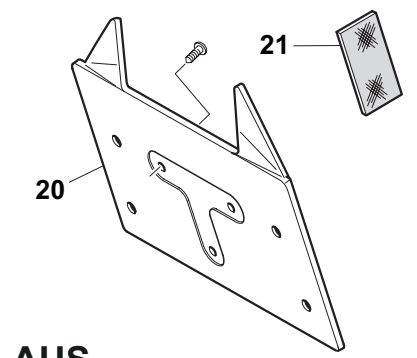

AUS

TAVOLA 30
DRAWING 30
TABLE 30
BILD 30
TABLA 30

TR 650 Terra/2013
TR 650 Strada/2013

TAVOLA - DRAWING
TABLE - BILD - TABLA

31

PANNELLI, PARAFANGHI POSTERIORI - REAR PANEL, FENDERS
PANNEAU, GARDE-BOUES ARRIERE - STREIFEN, KOTFLUGEL, HINTEN
PANELO, GUARDABARROS TRASERO



Note Notes Notes Marke Notas	Pos. No. N. Index Pos.	N. Cod. Code No. Nr. Code Code Nr N. Cod.	Q.tà Q.ty Q.te M.ge C.ad	DENOMINAZIONE	NAME	DESIGNATION	BESHREIBUNG	DENOMINACION
	1	8000H5318	1	Fianchetto Dx	RH fairing	Cache D	Seitenteil re	Costado dch.
	2	8000H5319	1	Fianchetto Sx	LH fairing	Cache G	Seitenteil li	Costado izq.
	3	8000H5321	1	Parafango posteriore interno	Internal rear mudguard	Garde-boue arrière intérieur	Hinterradkotflügel innen	Guardabarros trasero interno
	4	8000H5322	1	Portatarga	Number plate holder	Support plaque d'imm.	Nummernschildhalter	Portamatrícula
	5	800073834	1	Catadiottro	Reflector	Catadioptré	Rückstrahler	Catadióptrico
M4	6	Z00040717	2	Dado	Nut	Écrou	Mutter	Tuerca
	7	62ND15547	2	Rosetta	Washer	Rondelle	Unterlegscheibe	Arandela
	8	8000H7445	1	Maniglione	Handles	Poignée	Griff	Manilla
22,8 mm	9	8539320	2	Bussola	Bushing	Douille	Buchse	Casquillo
10,2 mm	10	8539319	2	Bussola	Bushing	Douille	Buchse	Casquillo
	11	8000H7455	1	Parafango posteriore	Rear mudguard	Garde-boue arrière	Hinterradkotflügel	Guardabarros trasero
	12	8000H7632	1	Coperchietto	Cover	Couvercle	Deckel	Tapa
M5x14	13	8539451	28	Vite	Screw	Vis	Schraube	Tornillo
	14	7651465	25	Dado a graffetta	Clip nut	Ecrou à agrafe	Sicherungsmutter	Tuerca de clip
	15	7694548	1	Dado a graffetta	Clip nut	Ecrou à agrafe	Sicherungsmutter	Tuerca de clip
M8x25	16	8539470	2	Vite TCEI	Allen screw	Vis TCEI	Zyl. Schraube	Tornillo TCEI
M8x35	17	8539471	2	Vite TCEI	Allen screw	Vis TCEI	Zyl. Schraube	Tornillo TCEI
USA	18	7652118	1	Supporto targa	Licence plate support	Support plaque d'imm.	Kennzeichenhalterung	Soporte matrícula
USA	19	800073832	2	Catadiottro rosso	Red reflector	Catadioptré rouge	Rückstrahler Rot	Catadióptrico rojo
AUS	20	8539455	1	Protezione posteriore	Protection	Protection	Schutz	Protección
AUS	21	800074842	2	Catadiottro ambr	Amber reflector	Catadioptré ambre	Rückstrahler bernstein	Catadióptrico ámb

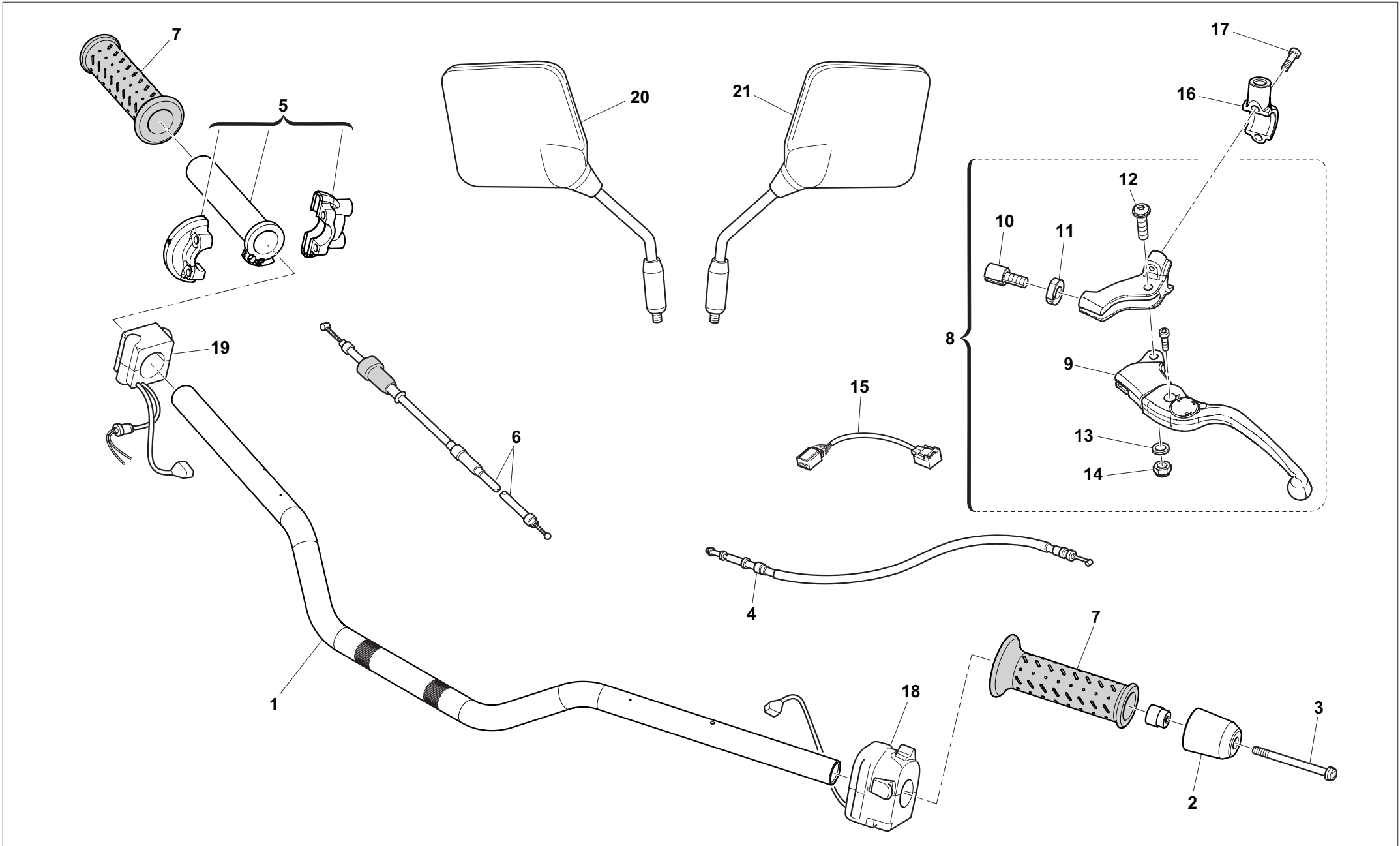

TR 650 Terra/2013
TR 650 Strada/2013

TAVOLA - DRAWING
TABLE - BILD - TABLA

32

MANUBRIO - HANDLEBAR
GUIDON - LENKER
MANILLAR



Note Notes Notes Marke Notas	Pos. No. Index Pos.	N. Cod. Code No. Nr. Code Code Nr N. Cod.	Q.tà Q.ty Q.te M.ge C.ad	DENOMINAZIONE	NAME	DESIGNATION	BESHREIBUNG	DENOMINACION
	1	7708103	1	Manubrio	Handlebar	Guidon	Lenker	Manillar
	2	7721634	2	Contrappeso	Counterweight	Contrepoids	Gegengewicht	Contrapeso
M6x45	3	8539458	2	Vite	Screw	Vis	Schraube	Tornillo
	4	8539124	1	Cavo	Cable	Câble	Kabel	Cable
	5	7714488	1	Comando gas completo	Complete throttle control	Commande des gaz complète	Gaszug komplett	Mando acelerador completo
	6	8539137	1	Cavo comando gas	Gas control drive cable	Transmission commande des gaz	Gaszug	Transmisión mando acelerador
	7	8539483	1	Kit manopole	Hand grip kit	Kit poignées	Satz Griffe	Kit puños
	8	7688439	1	Assieme comando frizione	Clutch control assy	Commande embrayage compl.	Zusammenbau Kupplungszug	Conjunto mando embrague
	9	8539433	1	Leva frizione regolabile	Clutch lever	Levier embrayage	Kupplungshebel	Palanca embrague
	10	7678100	1	Vite di registro	Adjuster screw	Vis de réglage	Einstellschraube	Tornillo de regulación
	11	7678101	1	Dado	Nut	Écrou	Mutter	Tuerca
M5x30	12	7673989	1	Vite	Screw	Vis	Schraube	Tornillo
	13	7680376	1	Rosetta	Washer	Rondelle	Unterlegscheibe	Arandela
	14	7680378	1	Dado	Nut	Écrou	Mutter	Tuerca
	15	8539269	1	Interruttore frizione	Clutch switch	Interrupteur embrayage	Schalter	Interruptor
	16	2345420	1	Cavallotto	Clamp	Boulon	Bügelschraube	Caballote
M6x25	17	9903807	2	Vite TE	Hexalobular screw	Vis TE	SK Schraube	Tornillo TE
ABS	18	8537293	1	Commutatore sinistro	LH switch	Commutateur gauche	Umschalter linke	Conmutador izquierdo
35 kW - no ABS	18	8000H3300	1	Commutatore sinistro	LH switch	Commutateur gauche	Umschalter linke	Conmutador izquierdo
	19	8000H3299	1	Commutatore destro	RH switch	Commutateur droit	Umschalter rechts	Conmutador derecho
	20	8A00H1673	1	Specchietto retrov. Dx	RH rear-view mirror	Rétrovisueur D	Rückspiegel re	Espejo retrov. dch.
	21	8000H1673	1	Specchietto retrov. Sx	LH rear-view mirror	Rétrovisueur G	Rückspiegel li	Espejo retrov. izq.

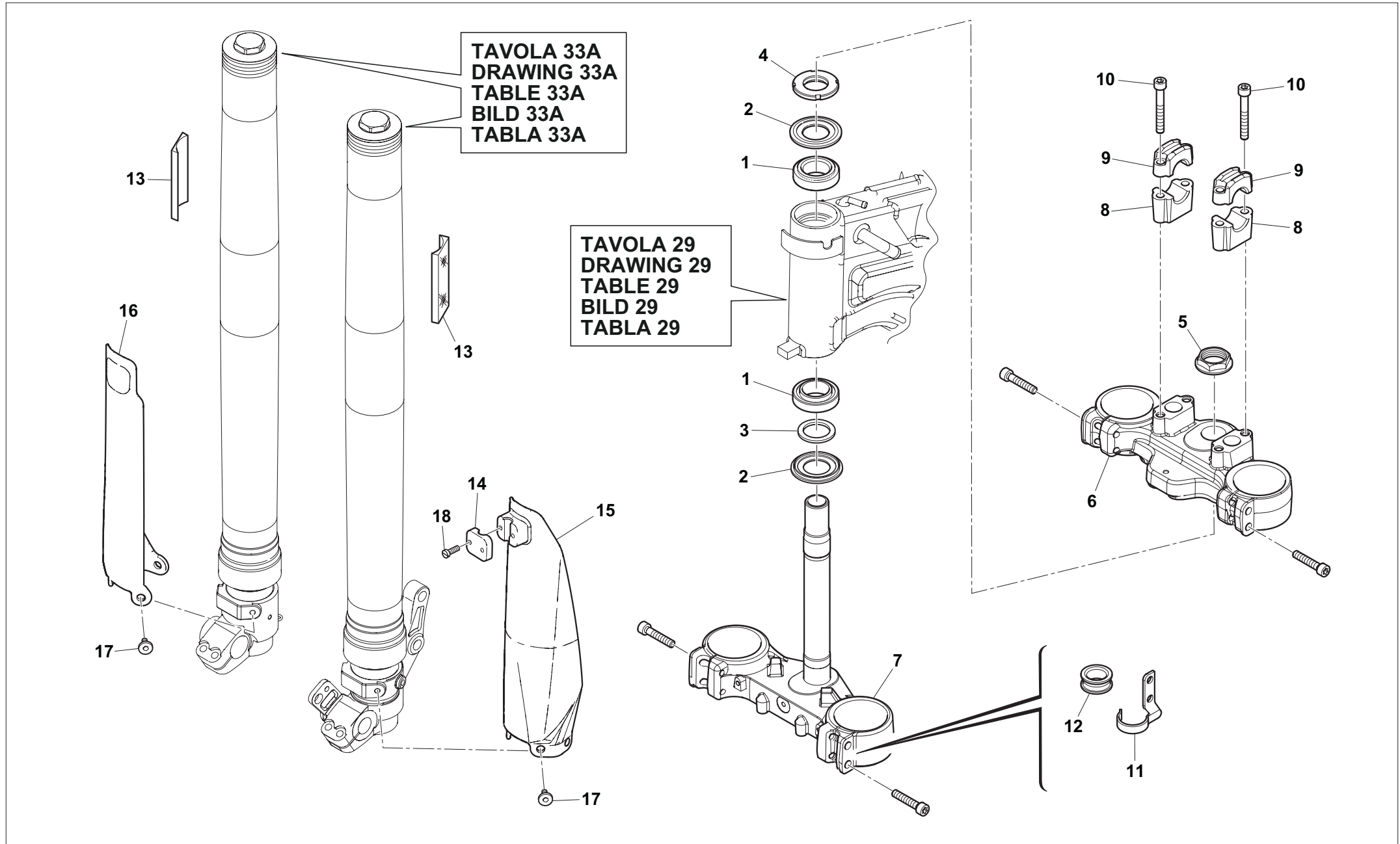

TR 650 Terra/2013
TR 650 Strada/2013

TAVOLA - DRAWING
TABLE - BILD - TABLA

33

FORCELLA - FORK
FOURCHE - GABEL
HORQUILLA



Note Notes Notes Marke Notas	Pos. No. N. Index Pos.	N. Cod. Code No. Nr. Code Code Nr N. Cod.	Q.tà Q.ty Q.te M.ge C.ad	DENOMINAZIONE	NAME	DESIGNATION	BESHREIBUNG	DENOMINACION
	1	800087243	2	Cuscinetto	Bearing	Roulement	Lager	Cojinete
	2	800087745	2	Guarnizione di tenuta	Gasket ring	Joint d'étanchéité	Dichtung	Junta de estanqueidad
	3	Z00087736	1	Rosetta	Washer	Rondelle	Unterlegscheibe	Arandela
	4	8A0087717	1	Ghiera	Ring nut	Bague	Gewindingring	Tuerca anular
M26x1	5	8A0069315	1	Dado	Nut	Écrou	Mutter	Tuerca
	6	8A00H7776	1	Testa di sterzo	Steering head	Tête de direction	Lenkkopf	Cabezal de dirección
	7	8A00H7784	1	Base di sterzo con perno	Bottom yoke with pin	Base de direction avec axe	Lenklager mit Bolzen	Base de dirección con eje
	8	8539133	2	Distanziale	Spacer	Entretoise	Abstandhalter	Distanciador
	9	8000H7873	2	Cavallotto	Clamp	Boulon	Bügelschraube	Caballote
M8x60	10	9904502	4	Vite	Screw	Vis	Schraube	Tornillo
	11	8538787	1	Piastrina	Plate	Plaquette	Plättchen	Placa
	12	800071806	1	Anello	Ring	Bague	Ring	Anillo
USA	13	800073842	2	Catadiottro ambra	Amber reflector	Catadiopre ambre	Rückstrahler bernstein	Catadióptrico ámbar
	14	80A0A0633	1	Passacavo	Cable retainer	Passe-câble	Kabeldurchführung	Pasacable
Terra	15	80A0A8481	1	Protezione stelo Sx	LH leg protection	Protection tiges G	Schutz Schäfte li	Protección vástagos izq.
Terra	16	80A0A8481	1	Protezione stelo Dx	RH leg protection	Protection tiges D	Schutz Schäfte re	Protección vástagos dch.
Terra	17	8539335	6	Vite	Screw	Vis	Schraube	Tornillo
Terra	18	ZA0084658	2	Vite	Screw	Vis	Schraube	Tornillo

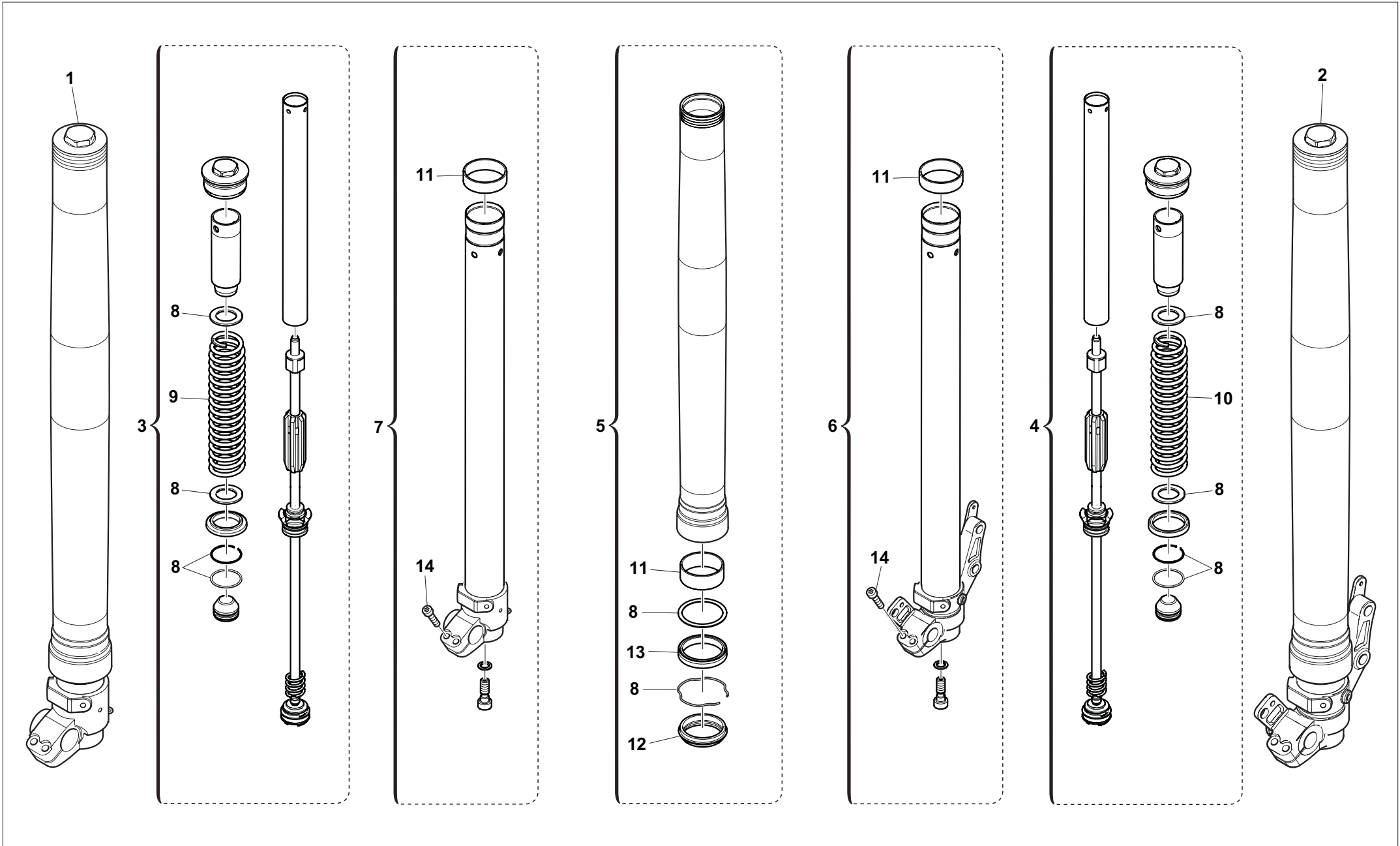

TR 650 Terra/2013
TR 650 Strada/2013

TAVOLA - DRAWING
TABLE - BILD - TABLA

33A

SOSPENSIONE ANTERIORE - FRONT FORK ASSEMBLY
SUSPENSION AVANT - VORDERTELESKOPGABEL
SUSPENSION DELANTERA



Note Notes Notes Marke Notas	Pos. No. Index Pos.	N. Cod. Code No. Nr. Code Code Nr N. Cod.	Q.tà Q.ty Q.te M.ge C.ad	DENOMINAZIONE	NAME	DESIGNATION	BESHREIBUNG	DENOMINACION
Strada	1	8539035	1	Gamba Dx completa	Complete RH leg	Branche D complète	Federbein re komplett	Pata dch. completa
Terra	1	8539041	1	Gamba Dx completa	Complete RH leg	Branche D complète	Federbein re komplett	Pata dch. completa
Strada	2	8539034	1	Gamba Sx completa	Complete LH leg	Branche G complète	Federbein li komplett	Pata izq. completa
Terra	2	8539040	1	Gamba Sx completa	Complete LH leg	Branche G complète	Federbein li komplett	Pata izq. completa
Strada	3	8539722	1	Gruppo pompante Dx	RH pumping member unit	Groupe de pompage D	Gruppe Pumpelement re	Grupo de bombeo dch.
Terra	3	8539711	1	Gruppo pompante Dx	RH pumping member unit	Groupe de pompage D	Gruppe Pumpelement re	Grupo de bombeo dch.
Strada	4	8539721	1	Gruppo pompante Sx	LH pumping member unit	Groupe de pompage G	Gruppe Pumpelement li	Grupo de bombeo izq.
Terra	4	8539710	1	Gruppo pompante Sx	LH pumping member unit	Groupe de pompage G	Gruppe Pumpelement li	Grupo de bombeo izq.
	5	8539712	2	Gruppo fodero	Fork outer tube	Groupe de fourreau	Mantelgruppe	Grupo botella
Strada	6	8539723	1	Stelo Sx completo	LH stem assy	Tige G complète	Schaft li kompl.	Vástago izq. completo
Terra	6	8539713	1	Stelo Sx completo	LH stem assy	Tige G complète	Schaft li kompl.	Vástago izq. completo
Strada	7	8539724	1	Stelo Dx completo	RH stem assy	Tige D complète	Schaft re kompl.	Vástago der. completo
Terra	7	8539714	1	Stelo Dx completo	RH stem assy	Tige D complète	Schaft re kompl.	Vástago der. completo
	8	8539715	1	Gruppo anelli OR	O-ring set	Grupe bagues OR	Dichtringgruppe	Grupo anillos OR
	9	8539716	1	Molla di compressione	Compression spring	Ressort de compression	Sfeder	Muelle de compresión
	10	8539720	1	Molla di estensione	Extention spring	Ressort de extension	Sfeder	Muelle de extención
	11	8539717	1	Gruppo boccole	Bushing set	Groupe douille	Buchse gruppe	Grupo buje
	12	8539718	1	Raschiapolvere	Dust seal	Cache-poussière	Staubabstreifer	Anillo quitapolvo
	13	8539719	1	Paraolio	Oil seal	Joint pare-huile	Öldichtring	Retén de aceite
M6x1 L=25 mm	14	9903807	4	Vite TE flangiata	Hex. flanged screw	Vis de bride TE	SK-Bundschraube	Perno de reborde TE

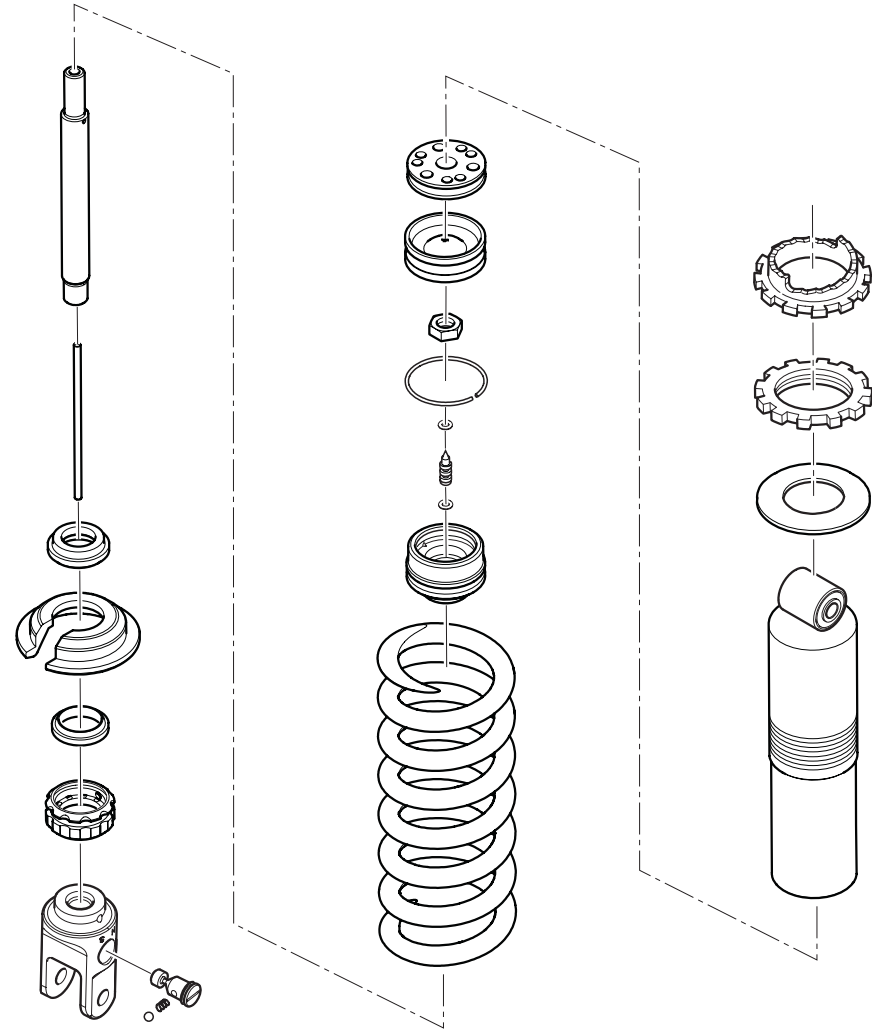
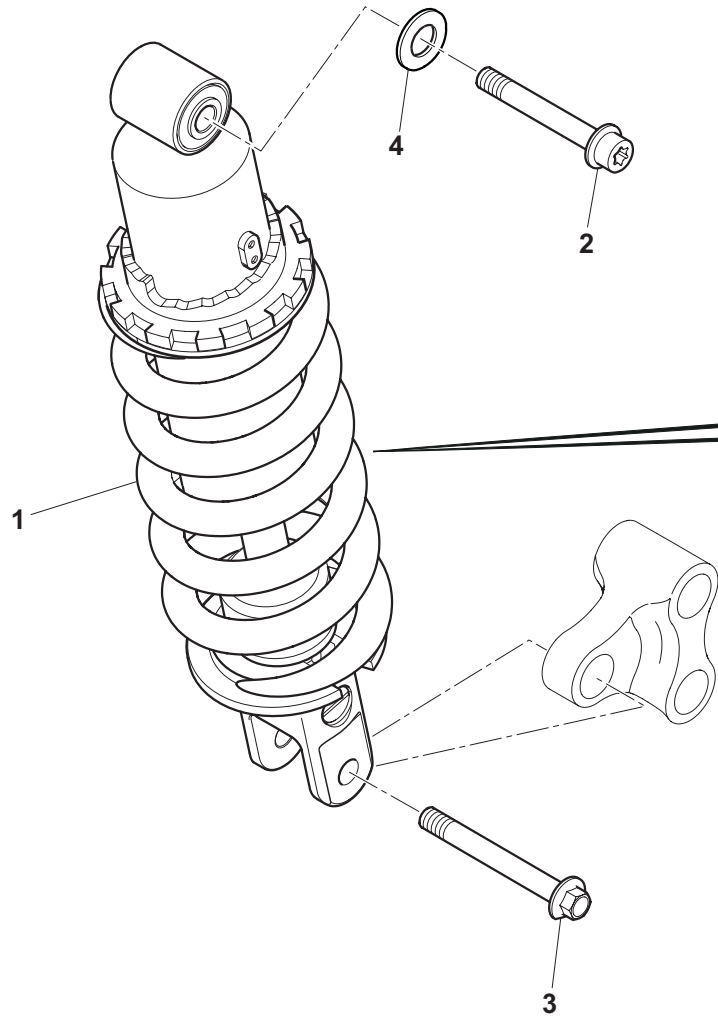

TR 650 Terra/2013
TR 650 Strada/2013

TAVOLA - DRAWING
 TABLE - BILD - TABLA

34

AMMORTIZZATORE POSTERIORE - REAR SUSPENSION
SUSPENSION ARRIERE - HINTERHAUFHANGUNG
SUSPENSION TRASERA



Note Notes Marke Notas	Pos. No. Index Pos.	N. Cod. Code No. Nr. Code Code Nr N. Cod.	Q.tà Q.ty Q.te M.ge C.ad	DENOMINAZIONE	NAME	DESIGNATION	BESHREIBUNG	DENOMINACION
Strada	1	8000H5198	1	Ammortizzatore completo	Complete shock absorber	Amortisseur complet	Stoßdämpfer komplett	Amortiguador completo
Terra	1	8538890	1	Ammortizzatore completo	Complete shock absorber	Amortisseur complet	Stoßdämpfer komplett	Amortiguador completo
M10x55	2	8538789	1	Vite	Screw	Vis	Schraube	Tornillo
M10x43	3	8538790	1	Vite TE	Hexalobular screw	Vis TE	SK Schraube	Tornillo TE
	4	9904607	1	Rosetta	Washer	Rondelle	Unterlegscheibe	Arandela

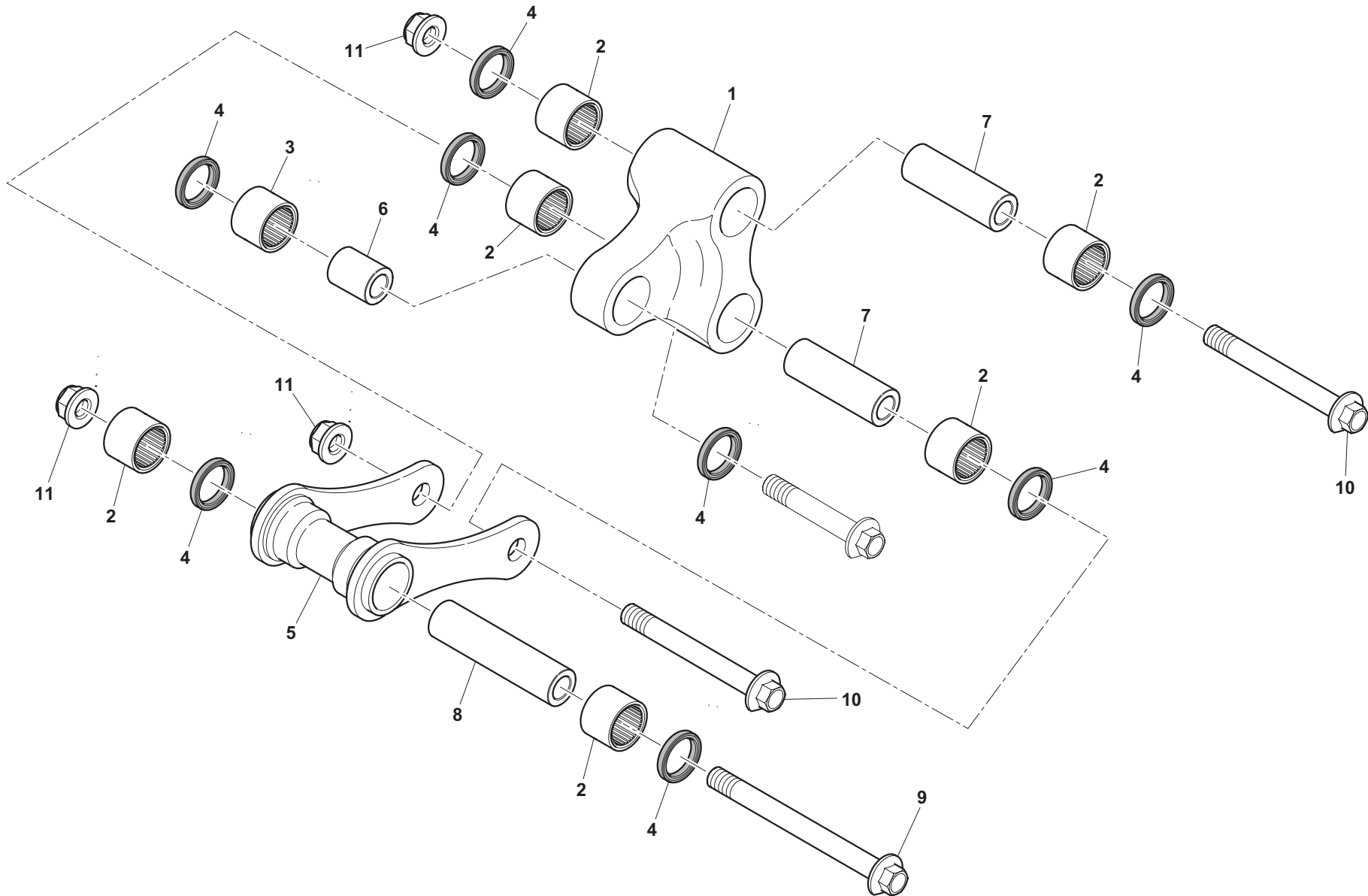

LEVERAGGI SOSPENSIONE POSTERIORE - REAR SUSPENSION LINKAGE
LEVIER SUSPENSION ARRIERE - HEBELWERK HINTERHAUFHANGUNG
PALANCA SUSPENSION TRASERA

Note Notes Notes Marke Notas	Pos. No. N. Index Pos.	N. Cod. Code No. Nr. Code Code Nr N. Cod.	Q.tà Q.ty Q.te M.ge C.ad	DENOMINAZIONE	NAME	DESIGNATION	BESHREIBUNG	DENOMINACION
	1	8000H6100	1	Bilanciere	Rocker arm	Culbuteur	Umlenk-Hebel	Balancín
Ø26xØ20x20	2	800042781	6	Astuccio a rullini	Axial roller and cage	Cage axiale à rouleaux	Axial-Rollenkäfig	Jaula axial de rodillos
	3	800032064	1	Gabbia a rulli	Ball bearing cage	Cage à rouleaux	Rollenkäfig	Jaula de rodillos
Ø26xØ20x4	4	800032065	8	Anello di tenuta	Sealing ring	Bague d'étanchéité	Dichtungsring	Anillo de estanqueidad
	5	8000H5200	1	Biella	Connecting rod	Bielle	Pleuel	Biela
Ø20xØ10x25,2	6	8000A4431	1	Spinotto	Piston pin	Goujon	Kolbenbolzen	Eje de pistón
60 mm	7	8A00H6132	2	Spinotto	Piston pin	Goujon	Kolbenbolzen	Eje de pistón
82 mm	8	8B00H6132	1	Spinotto	Piston pin	Goujon	Kolbenbolzen	Eje de pistón
M12x112	9	8E00H2753	1	Vite TE	Hexalobular screw	Vis TE	SK Schraube	Tornillo TE
M12x86	10	8F00H2753	2	Vite TE	Hexalobular screw	Vis TE	SK Schraube	Tornillo TE
M12x1,25	11	Z00042023	3	Dado	Nut	Écrou	Mutter	Tuerca

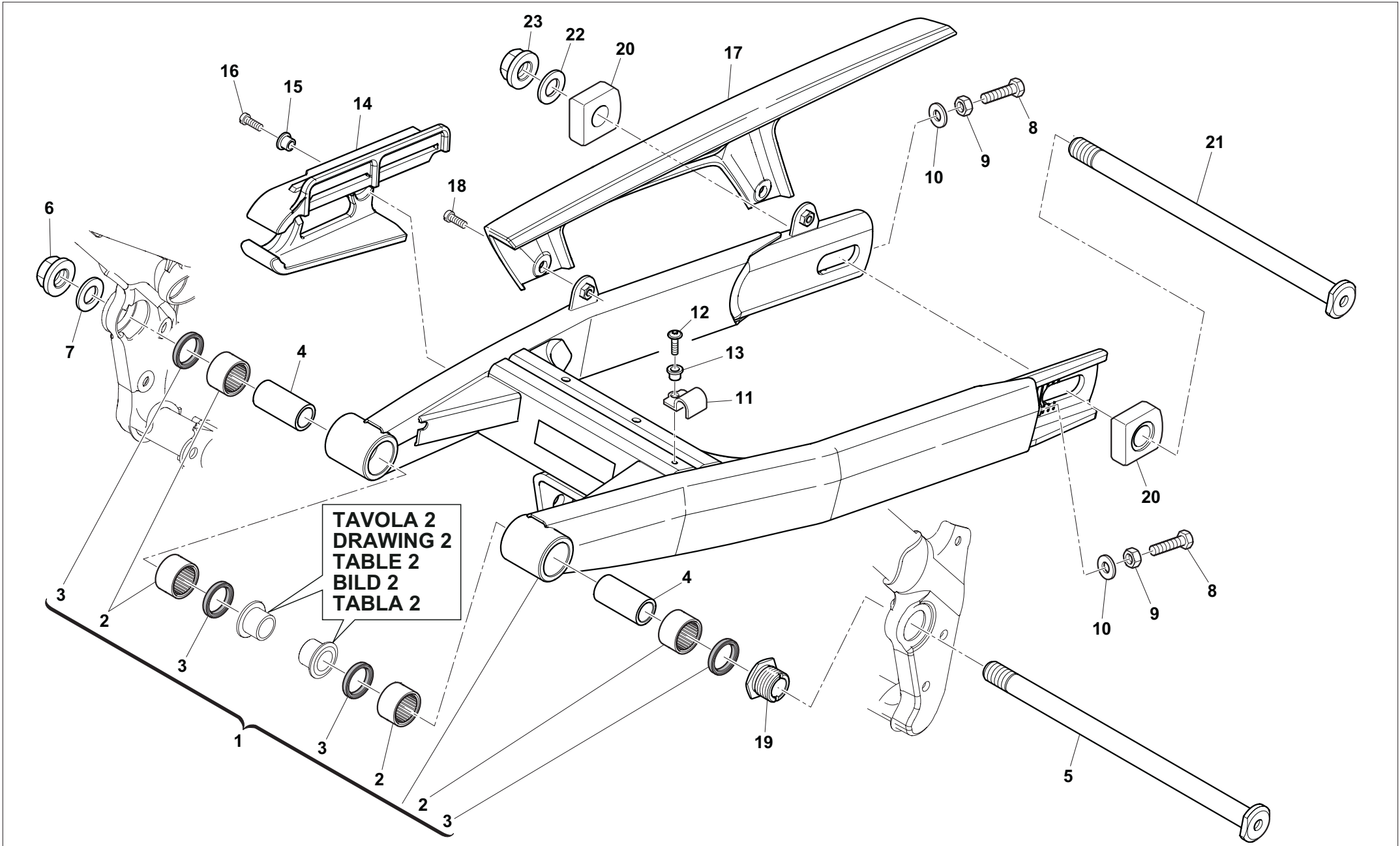

TR 650 Terra/2013
TR 650 Strada/2013

TAVOLA - DRAWING
TABLE - BILD - TABLA

36

FORCELLONE POSTERIORE - REAR SWING ARM
FOURCHE ARRIERE - HINTERGABEL
HORQUILLA TRASERA



Note Notes Notes Marke Notas	Pos. No. Index Pos.	N. Cod. Code No. Nr. Code Code Nr N. Cod.	Q.tà Q.ty Q.te M.ge C.ad	DENOMINAZIONE	NAME	DESIGNATION	BESHREIBUNG	DENOMINACION
	1	8539261	1	Forcellone completo	Complete swinging arm	Bras oscillant complet	Schwinge komplett	Basculante completo
Ø28xØ22x16	2	800086136	4	Astuccio a rullini	Ball bearing cage	Cage à rouleaux	Rollenkäfig	Jaula de rodillos
Ø28xØ22x4	3	800038521	4	Anello di tenuta	Sealing ring	Bague d'étanchéité	Dichtungsring	Anillo de estanqueidad
	4	8000H6182	2	Spinotto	Piston pin	Goujon	Kolbenbolzen	Eje de pistón
	5	8000H5186	1	Perno forcellone	Swinging arm pin	Axe bras oscillant	Bolzen Schwinge	Eje basculante
M16x1,5	6	Z00071623	1	Dado	Nut	Écrou	Mutter	Tuerca
	7	800032388	1	Rosetta	Washer	Rondelle	Unterlegscheibe	Arandela
M8x1,25	8	ZC0061121	2	Vite TE	Hexalobular screw	Vis TE	SK Schraube	Tornillo TE
M8	9	Z00017810	2	Dado	Nut	Écrou	Mutter	Tuerca
	10	9905733	2	Rosetta	Washer	Rondelle	Unterlegscheibe	Arandela
	11	800073456	1	Passatubo	Hose ring	Passe-tube	Leitungsdurchführung	Pasatubo
	12	9905798	1	Vite autofilettante	Self-tapping screw	Vis autotaraudeuse	Blechschrabe	Tornillo autorroscante
	13	800069282	1	Bussola	Bushing	Douille	Buchse	Casquillo
	14	8000H5191	1	Pattino catena	Chain slider	Patin chaîne	Kettenspannerauflage	Patín cadena
	15	8BA0H3017	1	Bussola con colletto	Bushing	Douille	Buchse	Casquillo
M6X16	16	8539444	1	Vite	Screw	Vis	Schraube	Tornillo
	17	7727156	1	Copricatena	Chain guard	Carter de chaîne	Kettenkasten	Cubrecadena
M6X14	18	7694305	2	Vite	Screw	Vis	Schraube	Tornillo
M24	19	8000H5951	1	Boccola	Bushing	Douille	Buchse	Casquillo
	20	8000H6605	2	Pattino tendicatena	Chain tensioner	Tendeur de chaîne	Kettenspanner	Tensor de cadena
	21	8000H6604	1	Perno ruota	Wheel axle	Pivot de roue	Radasche	Eje rueda
	22	800032388	1	Rosetta	Washer	Rondelle	Unterlegscheibe	Arandela
M16x1,5	23	9906784	1	Dado	Nut	Écrou	Mutter	Tuerca

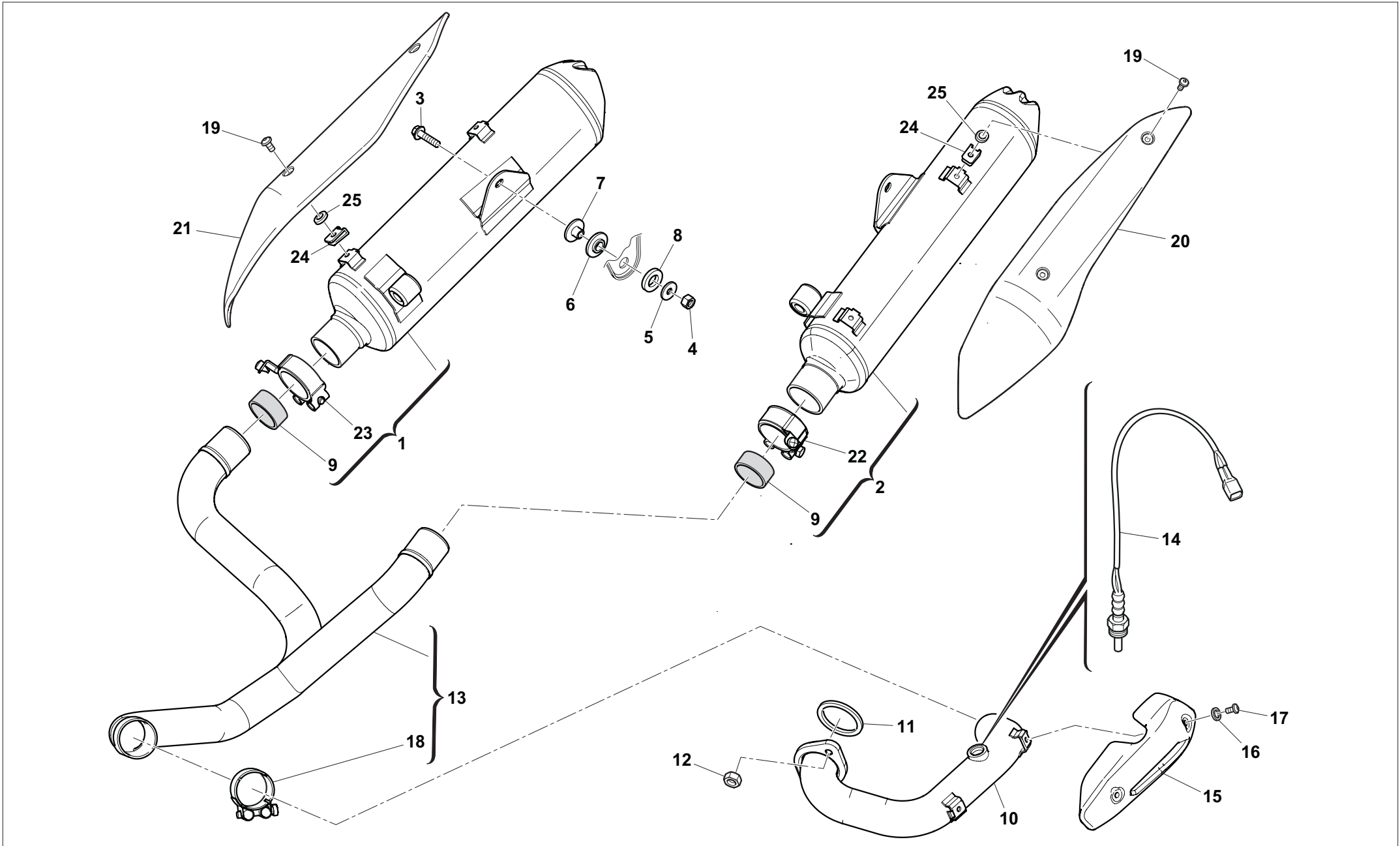

TR 650 Terra/2013
TR 650 Strada/2013

TAVOLA - DRAWING
TABLE - BILD - TABLA

37

SCARICO - EXHAUST SYSTEM
TUYAU D'ÉCHAPPEMENT - AUSPUFFROHR
TUBO DE ESCAPE



Note Notes Notes Marke Notas	Pos. No. N. Index Pos.	N. Cod. Code No. Nr. Code Code Nr N. Cod.	Q.tà Q.ty Q.te M.ge C.ad	DENOMINAZIONE	NAME	DESIGNATION	BESHREIBUNG	DENOMINACION
	1	8000H5214	1	Silenziatore Dx	RH silencer	Silencieux D	Schalldämpfer re	Silenciador dch.
Terra - USA	1	8538992	1	Silenziatore Dx	RH silencer	Silencieux D	Schalldämpfer re	Silenciador dch.
	2	8000H6093	1	Silenziatore Sx	LH silencer	Silencieux G	Schalldämpfer li	Silenciador izq.
Terra - USA	2	8538993	1	Silenziatore Sx	LH silencer	Silencieux G	Schalldämpfer li	Silenciador izq.
M8x30	3	ZC0069056	2	Vite TE	Hexalobular screw	Vis TE	SK Schraube	Tornillo TE
M8	4	9905977	2	Dado	Nut	Écrou	Mutter	Tuerca
	5	9904164	2	Rosetta	Washer	Rondelle	Unterlegscheibe	Arandela
	6	8000H4200	2	Passacavo	Cable ring	Passe-câble	Kabeldurchführung	Pasacable
	7	8000H7742	2	Bussola	Bushing	Douille	Buchse	Casquillo
	8	800061362	2	Gommino	Rubber ring	Joint en caoutchouc	Gummischeibe	Goma
	9	8539661	2	Guarnizione	Gasket	Joint	Dichtung	Junta
	10	8000H5216	1	Collettore	Manifold	Collecteur	Krümmer	Colector
	11	2343587	1	Guarnizione	Gasket	Joint	Dichtung	Junta
	12	9905977	2	Dado	Nut	Écrou	Mutter	Tuerca
	13	8000H6094	1	Collettore	Manifold	Collecteur	Krümmer	Colector
	14	7674452	1	Sonda Lambda	Lambda sensor	Sonde Lambda	Lambdasonde	Sonda Lambda
	15	8538470	1	Protezione	Protection	Protection	Schutz	Protección
	16	62ND15778	6	Rosetta	Washer	Rondelle	Unterlegscheibe	Arandela
M6x14	17	7694305	2	Vite	Screw	Vis	Schraube	Tornillo
	18	8539682	1	Fascetta	Clamp	Collier	Schelle	Abrazadera
M6x14	19	7694305	4	Vite	Screw	Vis	Schraube	Tornillo
	20	8000H6811	1	Protezione Sx	LH protection	Protection G	Schutz li	Protección izq.
	21	8000H6812	1	Protezione Dx	RH protection	Protection D	Schutz re	Protección dch.
	22	8539681	1	Fascetta Sx	LH Clamp	Collier G	Schelle li	Abrazadera izq.
	23	8539680	1	Fascetta Dx	RH Clamp	Collier D	Schelle re	Abrazadera dch.
	24	U00046893	4	Dado a graffetta	Clip nut	Ecrou à agrafe	Sicherungsmutter	Tuerca de clip
	25	800035112	4	Rosetta anticalore	Heat-protecting washer	Rondelle anti-chaleur	Unterlegscheibe	Arandela anticalor

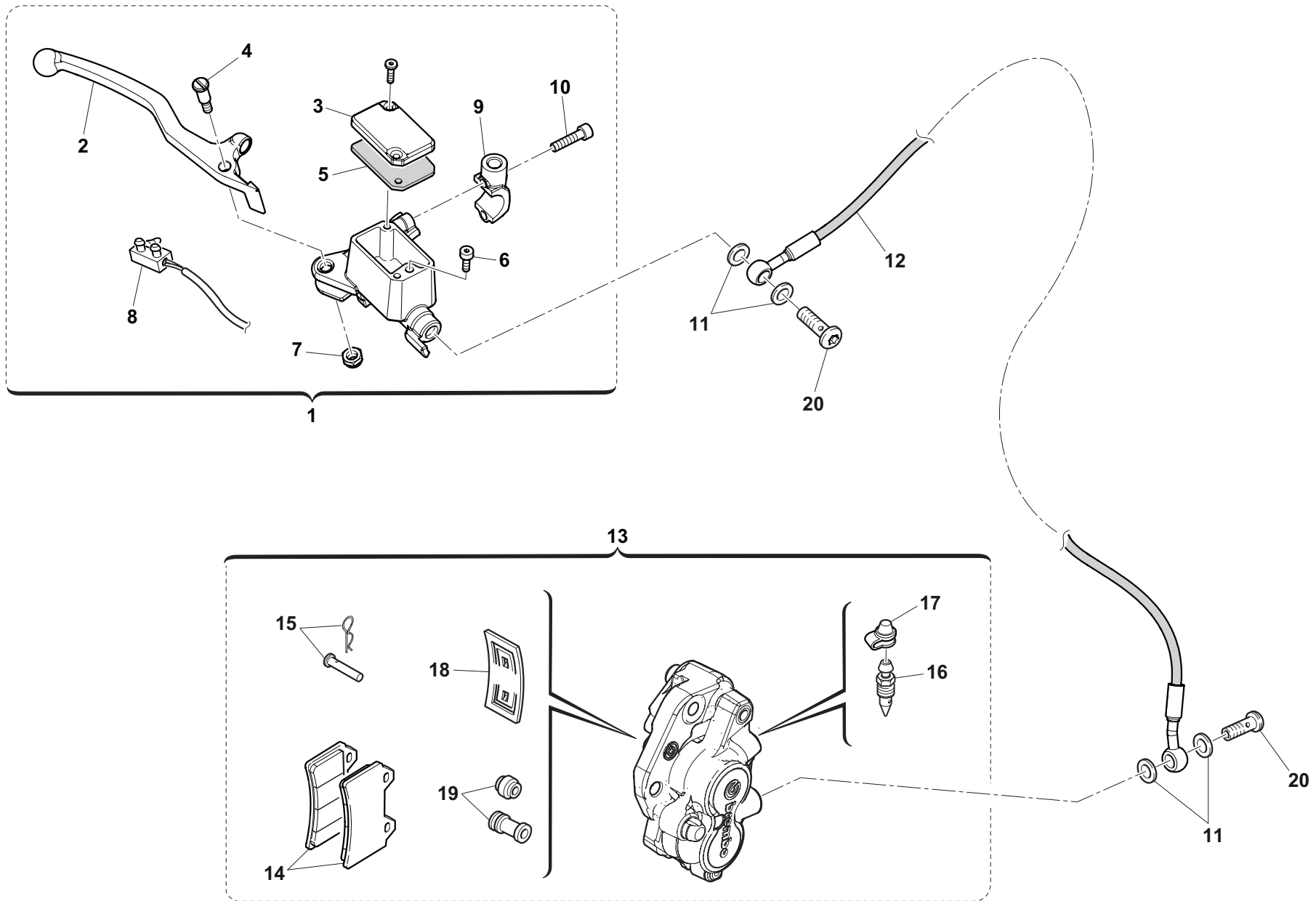

TR 650 Terra/2013
TR 650 Strada/2013

TAVOLA - DRAWING
TABLE - BILD - TABLA

38

FRENO IDRAULICO ANTERIORE - FRONT HYDRAULIC BRAKE
FREIN HYDRAULIQUE AVANT - VORDERBREMSE
FRENO HIDRAULICO DELANTERO



Note Notes Notes Marke Notas	Pos. No. Index Pos.	N. Cod. Code No. Nr. Code Code Nr N. Cod.	Q.tà Q.ty Q.te M.ge C.ad.	DENOMINAZIONE	NAME	DESIGNATION	BESHREIBUNG	DENOMINACION
	1	8538791	1	Pompa freno anteriore	Front master cylinder	Maître-cylindre de frein avant	Hauptbremszylinder vorne	Bomba freno delantero
	2	8539272	1	Leva	Lever	Levier	Hebel	Palanca
	3	8539273	1	Tappo	Plug	Bouchon	Stopfen	Tapón
	4	8539274	1	Perno	Pin	Axe	Bolzen	Eje
	5	800079099	1	Antiemulsione	Antiemulsion	Anti-émulsion	Demulgierendes Additiv	Antiemulsión
	6	8539275	1	Vite di spurgo	Bleed screw	Vis de purge	Entlüftungsschraube	Tornillo de purga
	7	8539276	1	Dado	Nut	Écrou	Mutter	Tuerca
	8	8539277	1	Microinterruttore freno anteriore	Front brake microswitch	Microinterrupteur frein avant	Mikroschalter Vorderradbremse	Microinterruptor freno delantero
	9	8539278	1	Cavallotto	Clamp	Boulon	Bügelschraube	Caballete
M6x25	10	9903807	2	Vite TE	Hexalobular screw	Vis TE	SK Schraube	Tornillo TE
no ABS	11	8539140	4	Rosetta	Washer	Rondelle	Unterlegscheibe	Arandela
	12	8000H6832	1	Tubo	Pipe	Tube	Rohr	Tubo
	13	8538956	1	Pinza freno anteriore	Front brake calliper	Etrier de frein	Bremssattel	Pinza freno
	14	8539279	1	Pastiglia	Pad	Plaquette	Bremsbelag	Pastilla
	15	8000A0936	1	Perno copiglia	Split pin	Axe goupille	Bolzen Splint	Eje pasador
	16	8539280	1	Vite di spurgo	Bleed screw	Vis de purge	Entlüftungsschraube	Tornillo de purga
	17	8000A2042	1	Parapolvere	Dust seal	Cache-poussières	Staubschutz	Guardapolvo
	18	8539281	1	Molla-lamierino	Spring-plate	Ressort-plaquette	Feder-Blech	Muelle-chapa
	19	800079066	1	Cuffia	Cap	Coiffe	Haube	Carcasa
M10x1	20	7667316	2	Vite forata	Screw	Vis	Schraube	Boca

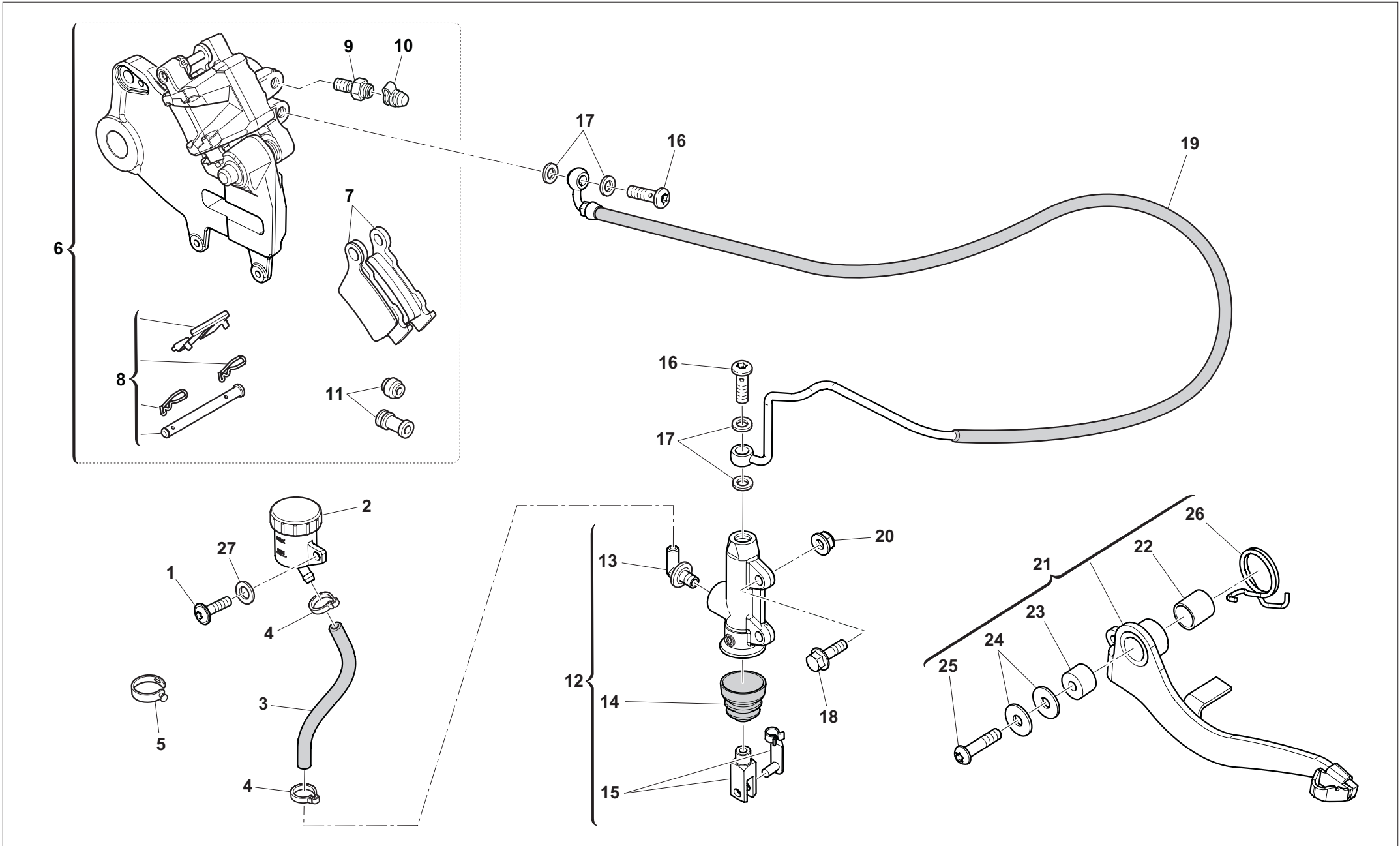

TR 650 Terra/2013
TR 650 Strada/2013

TAVOLA - DRAWING
TABLE - BILD - TABLA

39

FRENO IDRAULICO POSTERIORE - REAR HYDRAULIC BRAKE
FREIN HYDRAULIQUE ARRIERE - HINTERBREMSE
FRENO HIDRAULICO TRASERO



Note Notes Marke Notas	Pos. No. N. Index Pos.	N. Cod. Code No. Nr. Code Code Nr N. Cod.	Q.tà Q.ty Q.te M.ge C.ad	DENOMINAZIONE	NAME	DESIGNATION	BESHREIBUNG	DENOMINACION
M6x14	1	7694305	1	Vite	Screw	Vis	Schraube	Tornillo
	2	800061078	1	Serbatoio	Tank	Réservoir	Tank	Depósito
0,1 m	3	8000H7754	1	Tubo	Pipe	Tube	Rohr	Tubo
	4	8537279	2	Fascetta	Clamp	Collier	Schelle	Abrazadera
	5	800092668	1	Fascetta in gomma	Rubber clamp	Collier en caoutchouc	Gummischelle	Abrazadera de goma
	6	8538957	1	Pinza freno posteriore	Rear brake calliper	Etrier de frein ar.	Bremssattel hint.	Pinza freno tras.
	7	8539283	2	Coppia pastiglie	Pair of brake pads	Paire plaquettes	Paar Bremsbeläge	Pareja pastillas
	8	8539284	1	Perno	Pin	Axe	Bolzen	Eje
	9	2330310	1	Vite di spurgo	Bleed screw	Vis de purge	Entlüftungsschraube	Tornillo de purga
	10	8000A2042	1	Parapolvere	Dust seal	Cache-poussières	Staubschutz	Guardapolvo
	11	800079066	1	Cuffia parapolvere	Dust seal	Cache-poussières	Staubschutz	Guardapolvo
	12	2345748	1	Pompa comando freno	Brake control pump	Pompe de commande frein	Hauptbremszylinder	Bomba mando freno
	13	800042345	1	Raccordo	Union	Raccord	Anschluss	Racor
	14	2314289	1	Parapolvere	Dust seal	Cache-poussières	Staubschutz	Guardapolvo
	15	8539282	1	Puntalino	Push rod	Embout	Stift	Punta
M10x1	16	7667316	2	Vite forata	Screw	Vis	Schraube	Boca
	17	8539140	4	Rosetta	Washer	Rondelle	Unterlegscheibe	Arandela
M6x25	18	9907146	2	Vite TE	Hexalobular screw	Vis TE	SK Schraube	Tornillo TE
no ABS	19	8000H6772	1	Tubo freno posteriore	Rear brake tube	Tuyau de frein arrière	Rohr Hinterradbremse	Tubo freno trasero
M6	20	Z00044240	2	Dado	Nut	Écrou	Mutter	Tuerca
	21	8000H6270	1	Leva	Lever	Levier	Hebel	Palanca
	22	1450231	1	Boccola	Bushing	Douille	Buchse	Casquillo
	23	2338162	1	Bussola	Bushing	Douille	Buchse	Casquillo
	24	9904164	2	Rosetta	Washer	Rondelle	Unterlegscheibe	Arandela
	25	7672808	1	Vite	Screw	Vis	Schraube	Tornillo
	26	7705366	1	Molla	Spring	Ressort	Feder	Muelle
	27	8538799	1	Rondella	Washer	Rondelle	Unterlegscheibe	Arandela

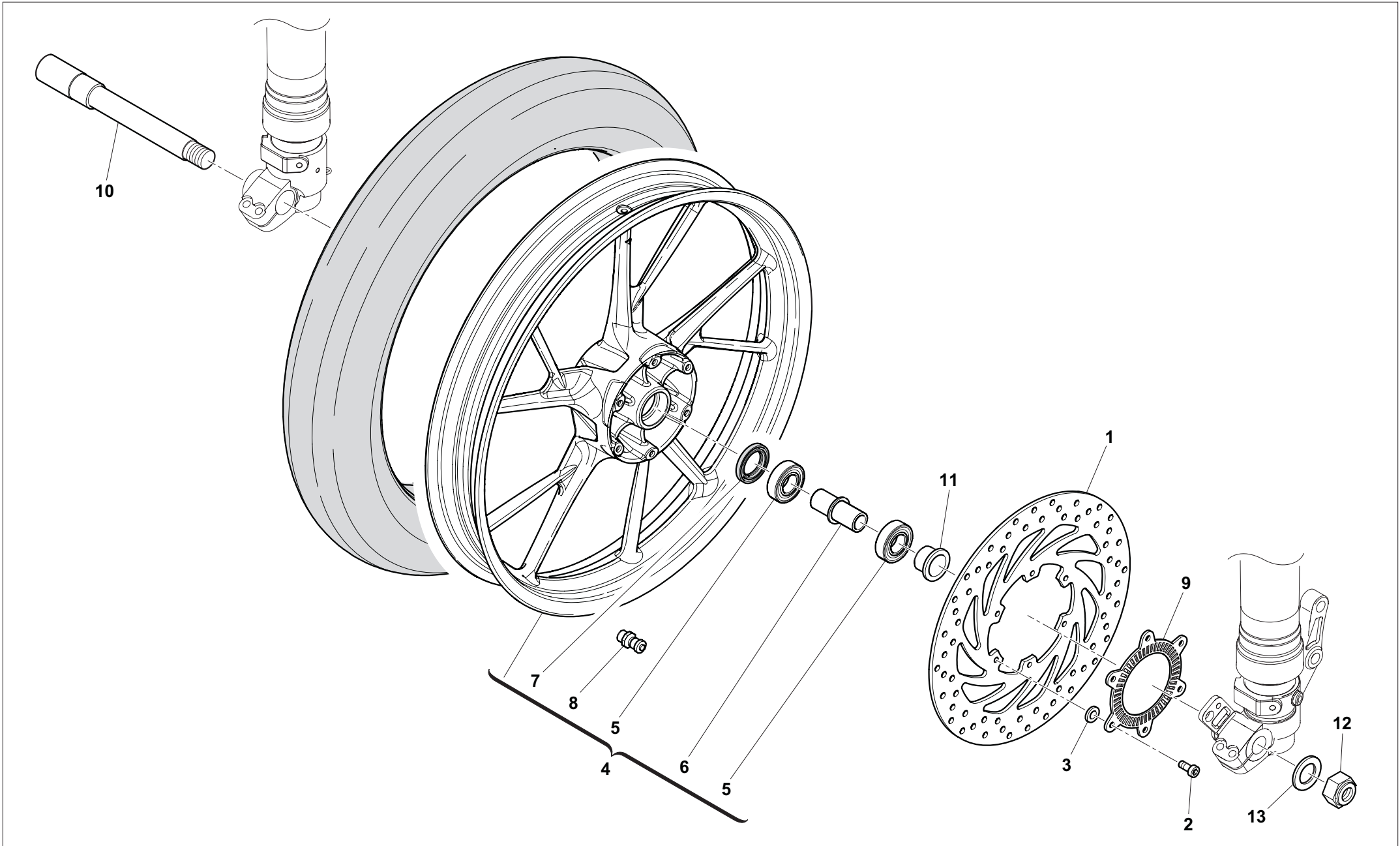

RUOTA ANTERIORE - FRONT WHEEL
ROUE AVANT - VORTERRAD
RUEDA DELANTERA



TAVOLA - DRAWING
TABLE - BILD - TABLA

40

Note Notes Notes Marke Notas	Pos. No. Index Pos.	N. Cod. Code No. Nr. Code Code Nr N. Cod.	Q.tà Q.ty Q.te M.ge C.ad	DENOMINAZIONE	NAME	DESIGNATION	BESHREIBUNG	DENOMINACION
	1	2345824	1	Disco freno	Brake disc	Disque de frein	Bremsscheibe	Disco freno
M6x20	2	7671267	6	Vite TCEI	Allen screw	Vis TCEI	Zyl. Schraube	Tornillo TCEI
	3	7661879	6	Rosetta	Washer	Rondelle	Unterlegscheibe	Arandela
Ø19" x 2,5"	4	7728605	1	Cerchio	Rim	Jante	Felge	Llanta
	5	2314724	2	Cuscinetto a sfere	Ball bearing	Roulement à billes	Kugellager	Cojinete de bolas
	6	2345821	1	Distanziale interno	Internal spacer	Entretoise intérieur	Abstandhalter	Distanciator interno
Ø25xØ40x7	7	9902384	1	Anello di tenuta	Sealing ring	Bague d'étanchéité	Dichtungsring	Anillo de estanqueidad
	8	7693061	1	Valvola	Valve	Soupape	Ventil	Válvula
	9	2345822	1	Ruota fonica	Tone wheel	Roue phonique	Impulsrad	Rueda fónica
	10	8000H6603	1	Perno ruota	Wheel axle	Pivot de roue	Radasche	Eje rueda
	11	8000H6136	1	Distanziale	Spacer	Entretoise	Abstandhalter	Distanciator
M16x1,5	12	9906784	1	Dado	Nut	Écrou	Mutter	Tuerca
	13	800032388	1	Rosetta	Washer	Rondelle	Unterlegscheibe	Arandela

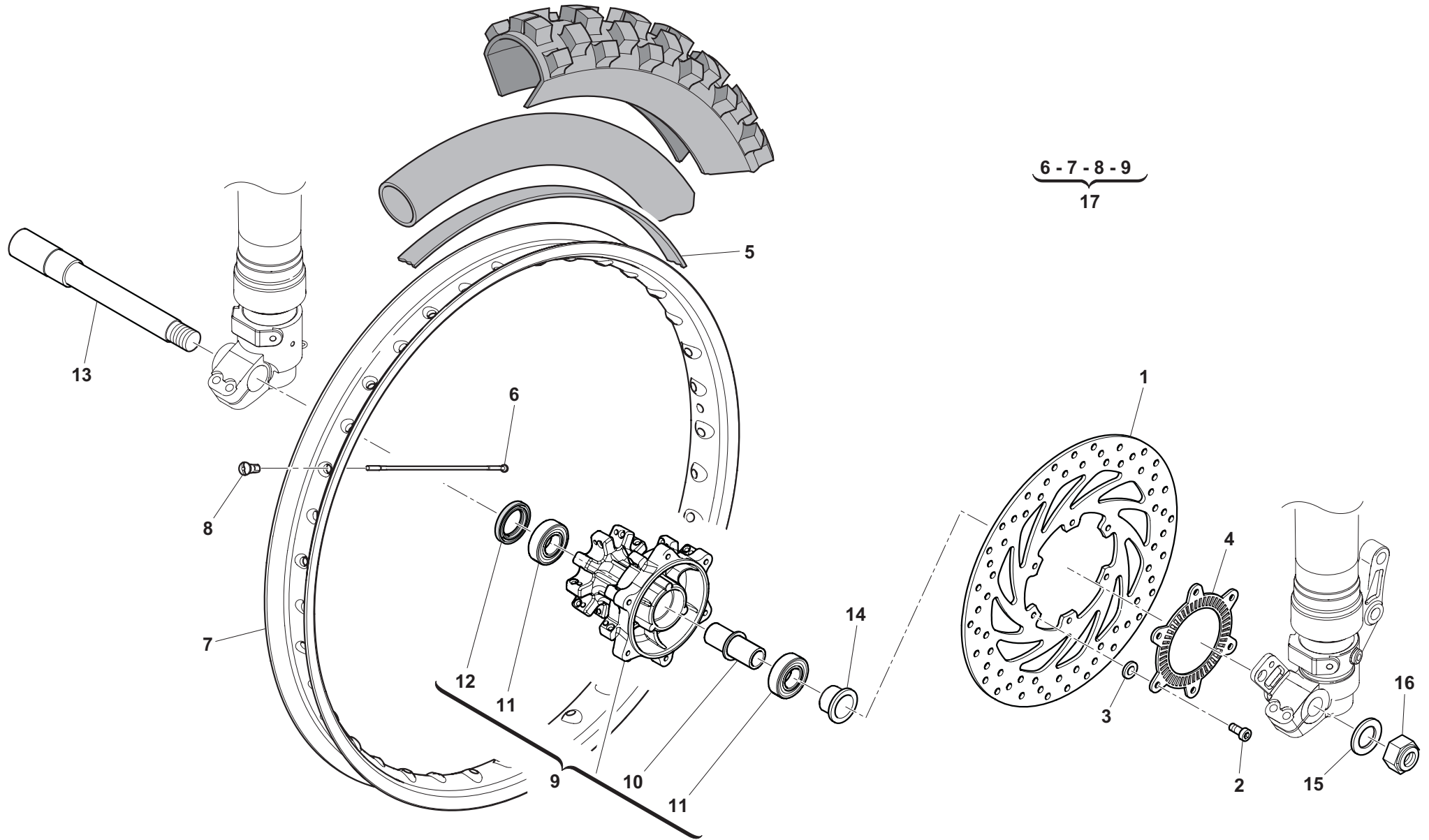

Note Notes Notes Marke Notas	Pos. No. Index Pos.	N. Cod. Code No. Nr. Code Code Nr N. Cod.	Q.tà Q.ty Q.te M.ge C.ad	DENOMINAZIONE	NAME	DESIGNATION	BESHREIBUNG	DENOMINACION
	1	2345824	1	Disco freno	Brake disc	Disque de frein	Bremsscheibe	Disco freno
M6x20	2	7671267	6	Vite TCEI	Allen screw	Vis TCEI	Zyl. Schraube	Tornillo TCEI
	3	7661879	6	Rosetta	Washer	Rondelle	Unterlegscheibe	Arandela
ABS	4	2345822	1	Ruota fonica	Tone wheel	Roue phonique	Impulsrad	Rueda fónica
	5	800013346	1	Guarnizione	Gasket	Joint	Dichtung	Junta
250 mm	6	7654449	18	Raggio	Spoke	Bras	Speiche	Radio
253 mm	6	7654450	18	Raggio	Spoke	Bras	Speiche	Radio
Ø21"x 1,85	7	8000H6830	1	Cerchio	Rim	Jante	Felge	Llanta
	8	8539837	36	Nipplo	Nipple	Nipple	Nippel	Niple
	9	7650053	1	Mozzo	Hub	Moyeu	Nabe	Cubo
	10	2345821	1	Bussola	Bushing	Douille	Buchse	Casquillo
Ø17xØ40x12	11	2314724	2	Cuscinetto a sfere	Ball bearing	Roulement à billes	Kugellager	Cojinete de bolas
Ø25xØ40x7	12	9902384	1	Anello di tenuta	Sealing ring	Bague d'étanchéité	Dichtungsring	Anillo de estanqueidad
	13	8000H6603	1	Perno ruota	Wheel axle	Pivot de roue	Radasche	Eje rueda
	14	8000H6136	1	Distanziale esterno	Spacer	Entretoise	Abstandhalter	Distanciador
	15	800032388	1	Rosetta	Washer	Rondelle	Unterlegscheibe	Arandela
M16x1,5	16	9906784	1	Dado	Nut	Écrou	Mutter	Tuerca
	17	8539144	1	Ruota anteriore nuda	Front wheel assy	Roue avant complète	Vorderrad komplett	Rueda delantera completa



TAVOLA 36
DRAWING 36
TABLE 36
BILD 36
TABLA 36

RUOTA POSTERIORE - REAR WHEEL
ROUE ARRIERE - HINTERRAD
RUEDA TRASERA
TAVOLA - DRAWING
TABLE - BILD - TABLA**42**

Note Notes Notes Marke Notas	Pos. No. Index Pos.	N. Cod. Code No. Nr. Code Code Nr N. Cod.	Q.tà Q.ty Q.te M.ge C.ad	DENOMINAZIONE	NAME	DESIGNATION	BESHREIBUNG	DENOMINACION
	1	2345314	1	Disco freno	Brake disc	Disque de frein	Bremsscheibe	Disco freno
M6x20	2	7671267	6	Vite TCEI	Allen screw	Vis TCEI	Zyl. Schraube	Tornillo TCEI
	3	2345813	1	Distanziale lato corona	Spacer	Entretoise	Abstandhalter	Distanciadador
Ø17"x3"	4	7728610	1	Cerchio	Rim	Jante	Felge	Llanta
	5	2345809	1	Distanziale interno	Internal spacer	Entretoise intérieur	Abstandhalter	Distanciadador interno
Ø17xØ40x12	6	2314724	3	Cuscinetto a sfere	Ball bearing	Roulement à billes	Kugellager	Cojinete de bolas
	7	9906782	1	Anello ritegno	Retaining circlip	Bague de retenue	Rückhaltering	Anillo de retención
	8	9965056	1	Anello di tenuta	Sealing ring	Bague d'étanchéité	Dichtungsring	Anillo de estanqueidad
	9	7693061	1	Valvola	Valve	Soupape	Ventil	Válvula
	10	2345810	1	Ruota fonica	Tone wheel	Roue phonique	Impulsrad	Rueda fónica
M5x10	11	9904491	3	Vite	Screw	Vis	Schraube	Tornillo
Z=47	12	8539202	1	Corona dentata	Chain sprocket	Couronne dentée	Zahnkranz	Corona dentada
M8x40	13	9905549	6	Vite	Screw	Vis	Schraube	Tornillo
	14	9905733	6	Rosetta	Washer	Rondelle	Unterlegscheibe	Arandela
	15	9905977	6	Dado	Nut	Écrou	Mutter	Tuerca
	16	8539664	1	Portacorona	Sprocket carrier	Support couronne	Zahnkranzhalterung	Portacorona
	17	2345812	1	Distanziale	Spacer	Entretoise	Abstandhalter	Distanciadador
	18	9981221	2	Cuscinetto a sfere	Ball bearing	Roulement à billes	Kugellager	Cojinete de bolas
	19	9903155	1	Anello ritegno	Retaining circlip	Bague de retenue	Rückhaltering	Anillo de retención
	20	7655483	1	Distanziale	Spacer	Entretoise	Abstandhalter	Distanciadador
Ø30xØ40x7	21	9965056	1	Anello di tenuta	Sealing ring	Bague d'étanchéité	Dichtungsring	Anillo de estanqueidad
	22	2345813	1	Distanziale esterno	Spacer	Entretoise	Abstandhalter	Distanciadador
	23	2345789	3	Gommino parastrappi	Anti-vibration buffer rubber ring	Joint amortisseur de couple	Gummischeibe Reißschutz	Goma acoplamiento elástico
	24	8000H5248	1	Catena	Chain	Chaîne	Kette	Cadena
	25	2345814	1	Distanziale lato disco	Spacer	Entretoise	Abstandhalter	Distanciadador

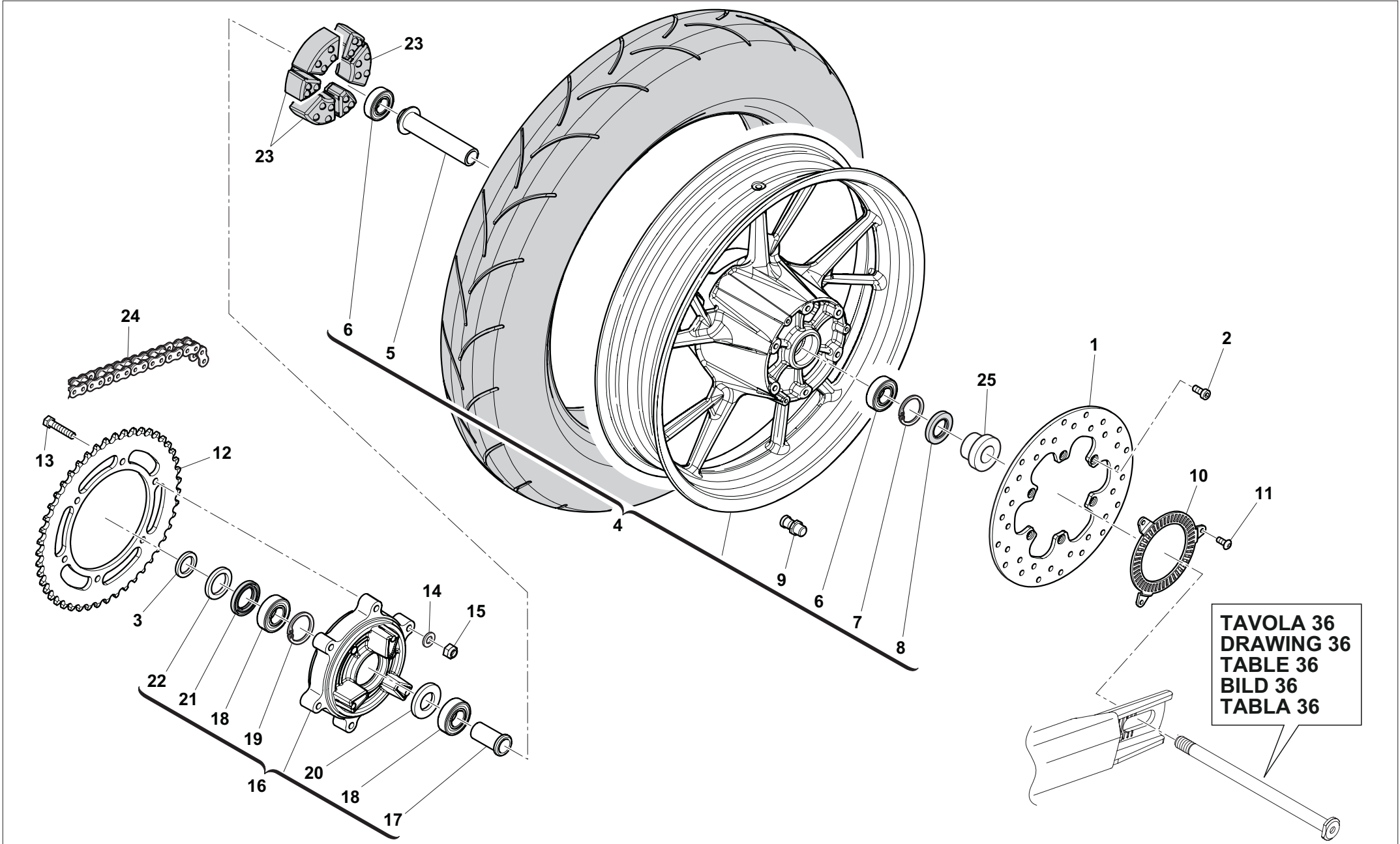
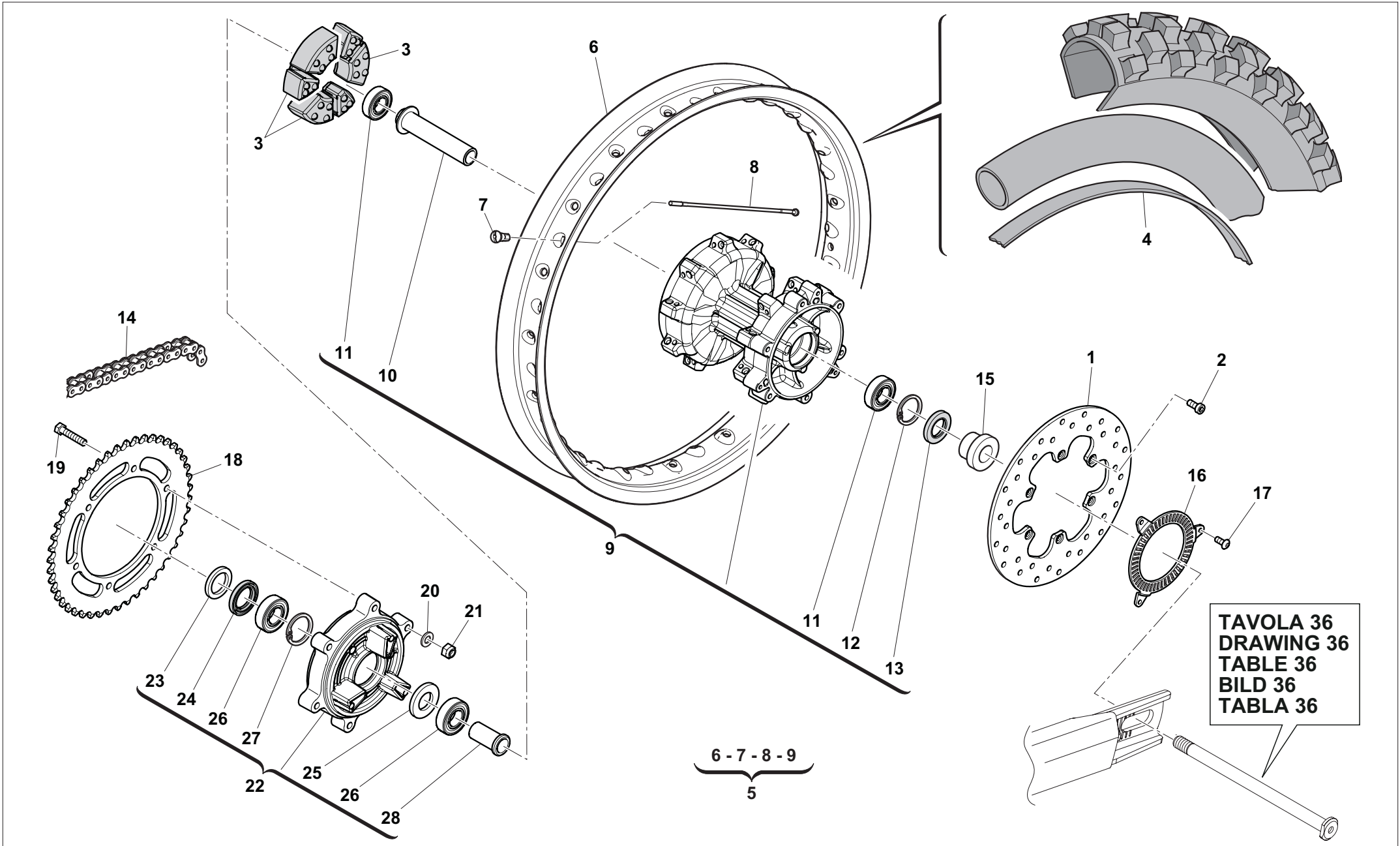

RUOTA POSTERIORE - REAR WHEEL
ROUE ARRIERE - HINTERRAD
RUEDA TRASERA
TAVOLA - DRAWING
TABLE - BILD - TABLA

43

Note Notes Notes Marke Notas	Pos. No. N. Index Pos.	N. Cod. Code No. Nr. Code Code Nr N. Cod.	Q.tà Q.ty M.ge C.ad	DENOMINAZIONE	NAME	DESIGNATION	BESHREIBUNG	DENOMINACION
	1	2345314	1	Disco freno	Brake disc	Disque de frein	Bremsscheibe	Disco freno
M6x20	2	7671267	6	Vite TCEI	Allen screw	Vis TCEI	Zyl. Schraube	Tornillo TCEI
	3	2345789	3	Gommino parastrappi	Anti-vibration buffer rubber ring	Joint amortisseur de couple	Gummischeibe Reißschutz	Goma acoplamiento elástico
ABS - Ø17"x3"	4	8B0082879	1	Guarnizione	Gasket	Joint	Dichtung	Junta
no ABS - Ø18"x3"	4	800001688	1	Guarnizione	Gasket	Joint	Dichtung	Junta
ABS - Ø17"x3"	5	8539145	1	Ruota posteriore nuda	Rear wheel assy	Roue arrière complète	Hinterrad komplett	Rueda trasera completa
no ABS - Ø18"x3"	5	8539190	1	Ruota posteriore nuda	Rear wheel assy	Roue arrière complète	Hinterrad komplett	Rueda trasera completa
ABS - Ø17"x3"	6	8538469	1	Cerchio	Rim	Jante	Felge	Llanta
no ABS - Ø18"x3"	6	8000H6825	1	Cerchio	Rim	Jante	Felge	Llanta
	7	8539837	36	Nipplo	Nipple	Nipple	Nippel	Niple
ABS - Ø17"x3"	8	2345807	36	Raggio	Spoke	Bras	Speiche	Radio
no ABS - Ø18"x3"	8	8000H6826	36	Raggio	Spoke	Bras	Speiche	Radio
	9	7650054	1	Mozzo	Hub	Moyeu	Nabe	Cubo
	10	2345809	1	Distanziale interno	Spacer	Entretoise	Abstandhalter	Distanciadore
Ø17xØ40x12	11	2314724	2	Cuscinetto a sfere	Ball bearing	Roulement à billes	Kugellager	Cojinete de bolas
	12	9906782	1	Anello ritegno	Retaining circlip	Bague de retenue	Rückhaltering	Anillo de retención
Ø30xØ40x7	13	9965056	1	Anello di tenuta	Sealing ring	Bague d'étanchéité	Dichtungsring	Anillo de estanqueidad
	14	8000H5248	1	Catena	Chain	Chaîne	Kette	Cadena
	15	2345814	1	Distanziale lato disco	Spacer	Entretoise	Abstandhalter	Distanciadore
	16	2345810	1	Ruota fonica	Tone wheel	Roue phonique	Impulsrad	Rueda fónica
M5x10	17	9904491	3	Vite	Screw	Vis	Schraube	Tornillo
Z=47	18	8539202	1	Corona dentata	Chain sprocket	Couronne dentée	Zahnkranz	Corona dentada
M8x40	19	9905549	6	Vite	Screw	Vis	Schraube	Tornillo
	20	9905733	6	Rosetta	Washer	Rondelle	Unterlegscheibe	Arandela
	21	9905977	6	Dado	Nut	Écrou	Mutter	Tuerca
	22	8539664	1	Portacorona	Sprocket carrier	Support couronne	Zahnkranzhalterung	Portacorona
	23	2345813	1	Distanziale esterno	Spacer	Entretoise	Abstandhalter	Distanciadore
Ø30xØ40x7	24	9965056	1	Anello di tenuta	Sealing ring	Bague d'étanchéité	Dichtungsring	Anillo de estanqueidad
	25	7655483	1	Distanziale	Spacer	Entretoise	Abstandhalter	Distanciadore
	26	9981221	2	Cuscinetto a sfere	Ball bearing	Roulement à billes	Kugellager	Cojinete de bolas
	27	9903155	1	Anello ritegno	Retaining circlip	Bague de retenue	Rückhaltering	Anillo de retención
	28	2345812	1	Distanziale interno	Spacer	Entretoise	Abstandhalter	Distanciadore



TAVOLA 28
DRAWING 28
TABLE 28
BILD 28
TABLA 28

TR 650 Terra/2013
TR 650 Strada/2013

TAVOLA - DRAWING
TABLE - BILD - TABLA

44

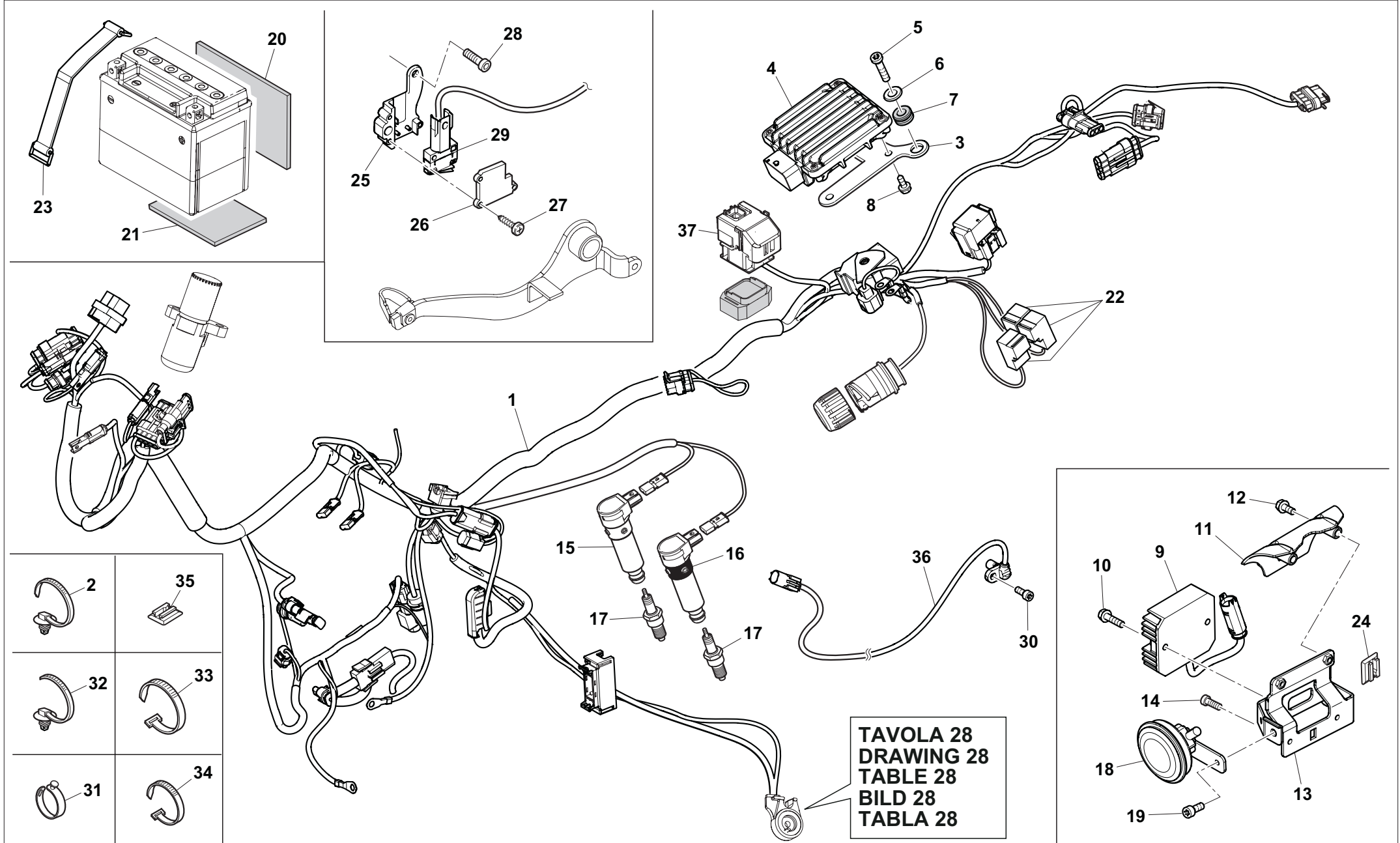
GRUPPO CAVI, PARTI ELETTRICHE - MAIN WIRING HARNESS, ELECTRICAL PARTS
CABLES PRINCIPAL, PARTIES ELECTRIQUES - KABEL, ELEKTRISCHE KOMPONENTE
GRUPO PRINCIPAL CABLES, PARTES ELECTRICAS



Note Notes Notes Marke Notas	Pos. No. N. Index Pos.	N. Cod. Code No. Nr. Code Code Nr N. Cod.	Q.tà Q.ty Q.te M.ge C.ad	DENOMINAZIONE	NAME	DESIGNATION	BESHREIBUNG	DENOMINACION
ABS	1	8538805	1	Cablaggio principale	Main cable harness	Câblage principal	Hauptverkabelung	Cableado principal
no ABS	1	8000H5283	1	Cablaggio principale	Main cable harness	Câblage principal	Hauptverkabelung	Cableado principal
	2	6915974	1	Fascetta	Clamp	Collier	Schelle	Abrazadera
	3	8000H7686	1	Supporto centralina	ECU support	Support centrale	Halterung Steuergerät	Soporte centralita
	4	CODED PART	1	Centralina elettronica	Electronic control unit	Boîtier électronique	Steuerelektronik	Centralita electrónica
	5	9904424	2	Vite autofilettante	Self-tapping screw	Vis autotaraudeuse	Blechschrabe	Tornillo autorroscante
	6	9904427	2	Rosetta	Washer	Rondelle	Unterlegscheibe	Arandela
	7	1233200	2	Antivibrante	Silent-block	Antivibration	Dämpfer	Anti-vibrador
	8	6777838	4	Vite autofilettante TBEI	Self-tapping screw	Vis autotaraudeuse	Blechschrabe	Tornillo autorroscante
	9	2346550	1	Regolatore di tensione	Voltage regulator	Régulateur de tension	Spannungsregler	Regulador de tensión
M6x25	10	8539442	2	Vite TE	Hexalobular screw	Vis TE	SK Schraube	Tornillo TE
	11	7728042	1	Protezione	Protection	Protection	Schutz	Protección
M5x20	12	9904792	2	Vite TCEI	Allen screw	Vis TCEI	Zyl. Schraube	Tornillo TCEI
	13	8000H6818	1	Piastra	Plate	Plaque	Platte	Placa
M5x14	14	8539448	2	Vite	Screw	Vis	Schraube	Tornillo
	15	7715848	1	Bobina candela secondaria	Secondary spark coil	Bobine bougie secondaire	Sekundär Zündspule	Bobina bujía secundario
	16	7715849	1	Bobina candela principale	Main spark coil	Bougie	Zündspule	Bujía
	17	8523867	2	Candela	Spark plug	Bougie	Zündkerze	Bujía
	18	7718054	1	Avvisatore acustico	Horn	Avertisseur sonore	Hupe	Avisador acústico
M6x12	19	7651203	1	Vite	Screw	Vis	Schraube	Tornillo
	20	8B0057673	1	Spessore elastico	Elastic spacer	Epaisseur élastique	Federdistanzstück	Distanciador elástico
	21	8C0057673	1	Spessore elastico	Elastic spacer	Epaisseur élastique	Federdistanzstück	Distanciador elástico
	22	8000A6749	3	Relè	Relay	Relais	Relais	Relé
	23	800077612	1	Cinghia	Belt	Courroie	Riemen	Correa
	24	1378997	2	Supporto	Support	Support	Halterung	Soporte
	25	8539191	1	Supporto	Support	Support	Halterung	Soporte
	26	8000H7830	1	Coperchio	Cover	Couvercle	Deckel	Tapa
	27	8537278	2	Vite autofilettante	Self-tapping screw	Vis autotaraudeuse	Blechschrabe	Tornillo autorroscante
M5x10	28	9904491	1	Vite	Screw	Vis	Schraube	Tornillo
	29	7727073	1	Interruttore stop posteriore	Rear stop switch	Interrupteur stop arrière	Bremslichtschalter	Interruptor freno trasero
	30	9905536	1	Vite	Screw	Vis	Schraube	Tornillo
	31	800092668	1	Fascetta in gomma	Rubber clamp	Collier en caoutchouc	Gummischelle	Abrazadera de goma
	32	6915974	4	Fascetta	Clamp	Collier	Schelle	Abrazadera



TAVOLA 28
DRAWING 28
TABLE 28
BILD 28
TABLA 28

TR 650 Terra/2013
TR 650 Strada/2013

TAVOLA - DRAWING
TABLE - BILD - TABLA

44

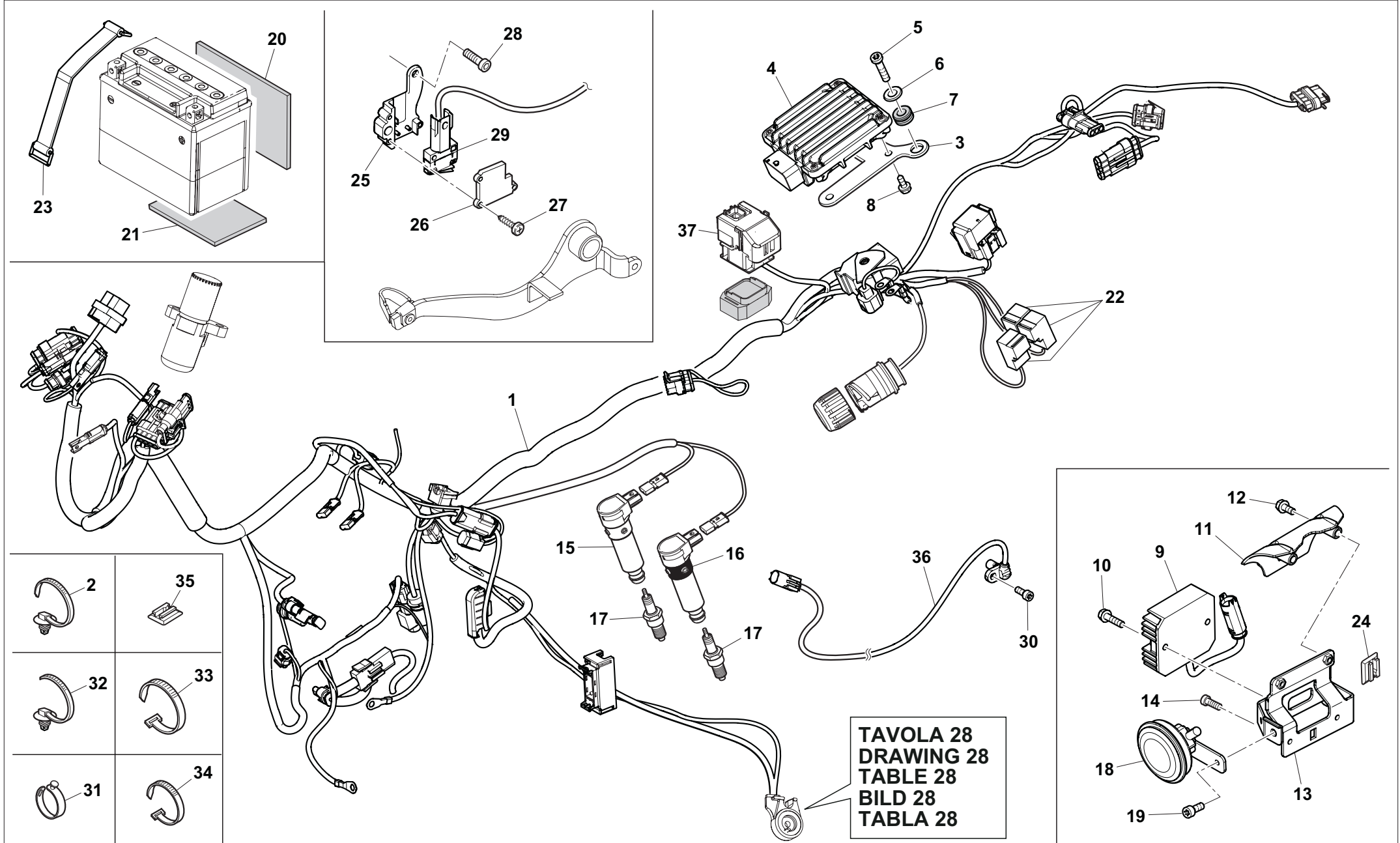
GRUPPO CAVI, PARTI ELETTRICHE - MAIN WIRING HARNESS, ELECTRICAL PARTS
CABLES PRINCIPAL, PARTIES ELECTRIQUES - KABEL, ELEKTRISCHE KOMPONENTE
GRUPO PRINCIPAL CABLES, PARTES ELECTRICAS



Note Notes Marke Notas	Pos. No. Index Pos.	N. Cod. Code No. Nr. Code Code Nr N. Cod.	Q.tà Q.ty Q.te M.ge C.ad	DENOMINAZIONE	NAME	DESIGNATION	BESHREIBUNG	DENOMINACION
	33	800056444	2	Fascetta	Clamp	Collier	Schelle	Abrazadera
	34	8539155	4	Fascetta	Clamp	Collier	Schelle	Abrazadera
	35	8539262	1	Clip fissaggio connettori	Connector fastening clip	Clip de fixation connecteurs	Befestigungsclip Kabelstecker	Clip fijación conectores
	36	7715117	2	Sensore velocità	Speed sensor	Capteur de vitesse	Geschwindigkeitssensor	Sensor velocidad
	37	7711474	1	Relè avviamento	Starter relay	Relais démarrage	Relais	Relé arranque

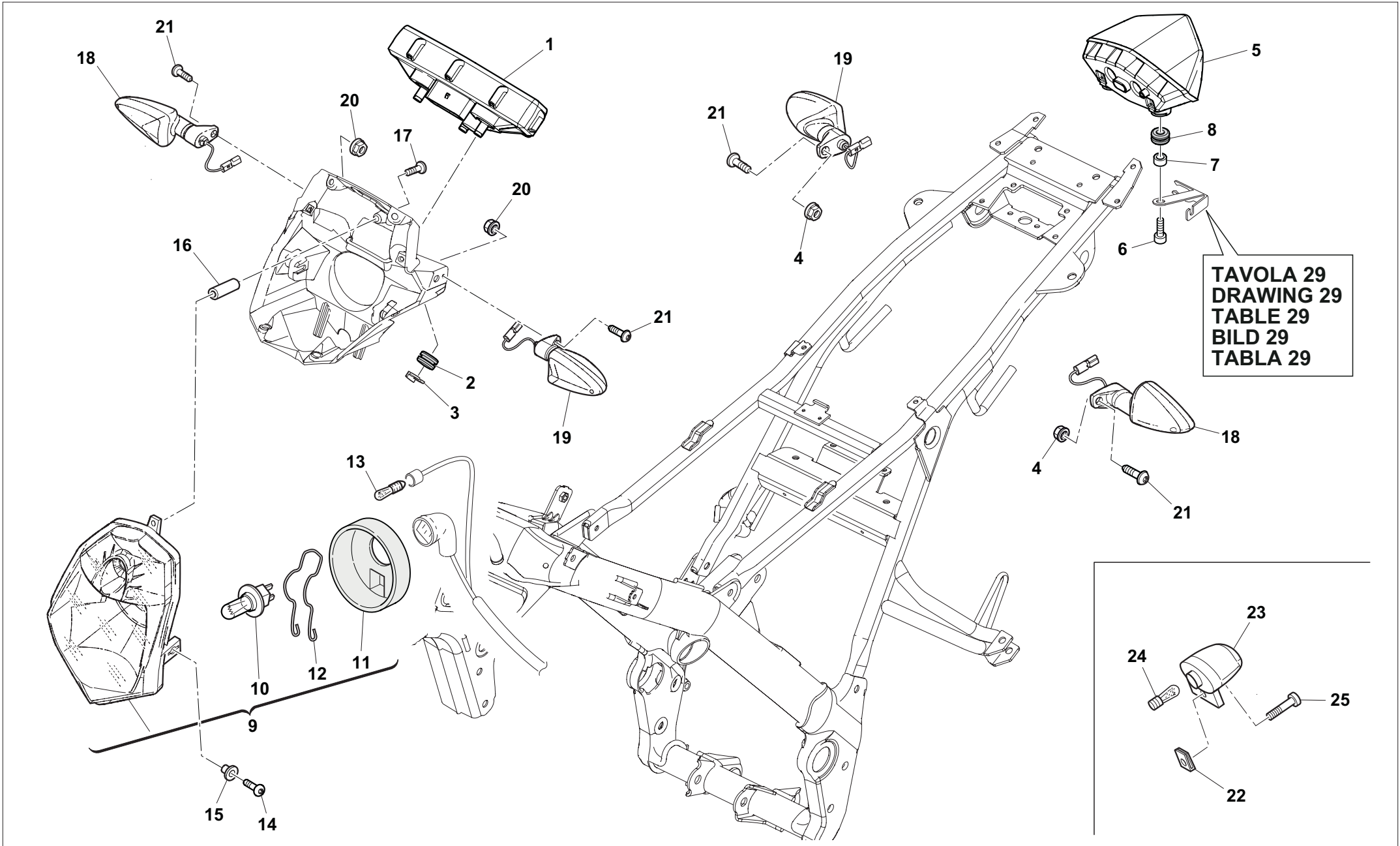

TR 650 Terra/2013
TR 650 Strada/2013

TAVOLA - DRAWING
TABLE - BILD - TABLA

45

**IMPIANTO ELETTRICO, STRUMENTO, FANALERIA - ELECTRIC SYSTEM LIGHT, DIGITAL INSTRUMENT
PARTES ELECTRIQUE, ECLAIRAGE, INSTRUMENT DIGITAL - ELEKTRISCHE KOMPONENTE, DIGITAL TACHOMETER
PARTES ELECTRICAS, ILUMINACION, INSTRUMENTO DIGITAL**



Note Notes Notes Marke Notas	Pos. No. Index Pos.	N. Cod. Code No. Nr. Code Code Nr N. Cod.	Q.tà Q.ty Q.te M.ge C.ad	DENOMINAZIONE	NAME	DESIGNATION	BESHREIBUNG	DENOMINACION
	1	CODED PART	1	Strumento digitale	Digital instrument	Instrument numérique	Digitalinstrument	Instrumento digital
	2	1233200	3	Gommino	Rubber ring	Joint en caoutchouc	Gummischeibe	Goma
	3	9906498	3	Molletta	Clip	Agrafe	Klammer	Pinza
	4	Z00044240	2	Dado	Nut	Écrou	Mutter	Tuerca
	5	8538462	1	Fanale posteriore	Tail light	Feu arrière	Heckscheinwerfer	Piloto trasero
	6	9905536	2	Vite	Screw	Vis	Schraube	Tornillo
	7	8000B2799	2	Distanziale	Spacer	Entretoise	Abstandhalter	Distanciadador
	8	800095128	2	Gommino	Rubber ring	Joint en caoutchouc	Gummischeibe	Goma
	9	8539053	1	Gruppo ottico anteriore	Headlight assembly	Groupe optique	Scheinwerfergruppe	Grupo óptico
12V-55/60W	10	8538867	1	Lampada	Bulb	Lampe	Lampe	Lámpara
	11	8000H1874	1	Cuffia	Cap	Coiffe	Haube	Carcasa
	12	8000H1873	1	Molletta	Clip	Agrafe	Klammer	Pinza
12V-5W	13	800036230	1	Lampada	Bulb	Lampe	Lampe	Lámpara
M6x14	14	8539468	2	Vite TC/Torx	Allen/Torx screw	Vis TC/Torx	Zyl./Torx Schraube	Tornillo TC/Torx
	15	8000H3017	2	Bussola	Bushing	Douille	Buchse	Casquillo
0,05 m	16	947200043	1	Tubo	Pipe	Tube	Rohr	Tubo
M5x70	17	8539445	1	Vite TCEI	Allen screw	Vis TCEI	Zyl. Schraube	Tornillo TCEI
	18	8534356	2	Indicatore direzione ant. Dx - post. Sx	Turn indicator front RH - rear LH	Clignotant av. D - ar. G	Richtungsanzeiger vorne re - hinten li	Intermitente del. dch. - tras. izq.
	19	8534357	2	Indicatore direzione ant. Sx - post. Dx	Turn indicator front LH - rear RH	Clignotant av. G - ar. D	Richtungsanzeiger vorne li - hinten re	Intermitente del. izq. - tras. dch.
M6	20	800048245	2	Dado	Nut	Écrou	Mutter	Tuerca
M6x16	21	8000H7760	4	Vite	Screw	Vis	Schraube	Tornillo
M5	22	9902745	1	Dado	Nut	Écrou	Mutter	Tuerca
	23	8000H6456	1	Luce targa	Licence plate light	Feu de plaque	Kennzeichenbeleuchtung	Luz matrícula
12V-5W	24	800036230	1	Lampada	Bulb	Lampe	Lampe	Lámpara
M5x16	25	60ND07330	1	Vite TCEI	Allen screw	Vis TCEI	Zyl. Schraube	Tornillo TCEI

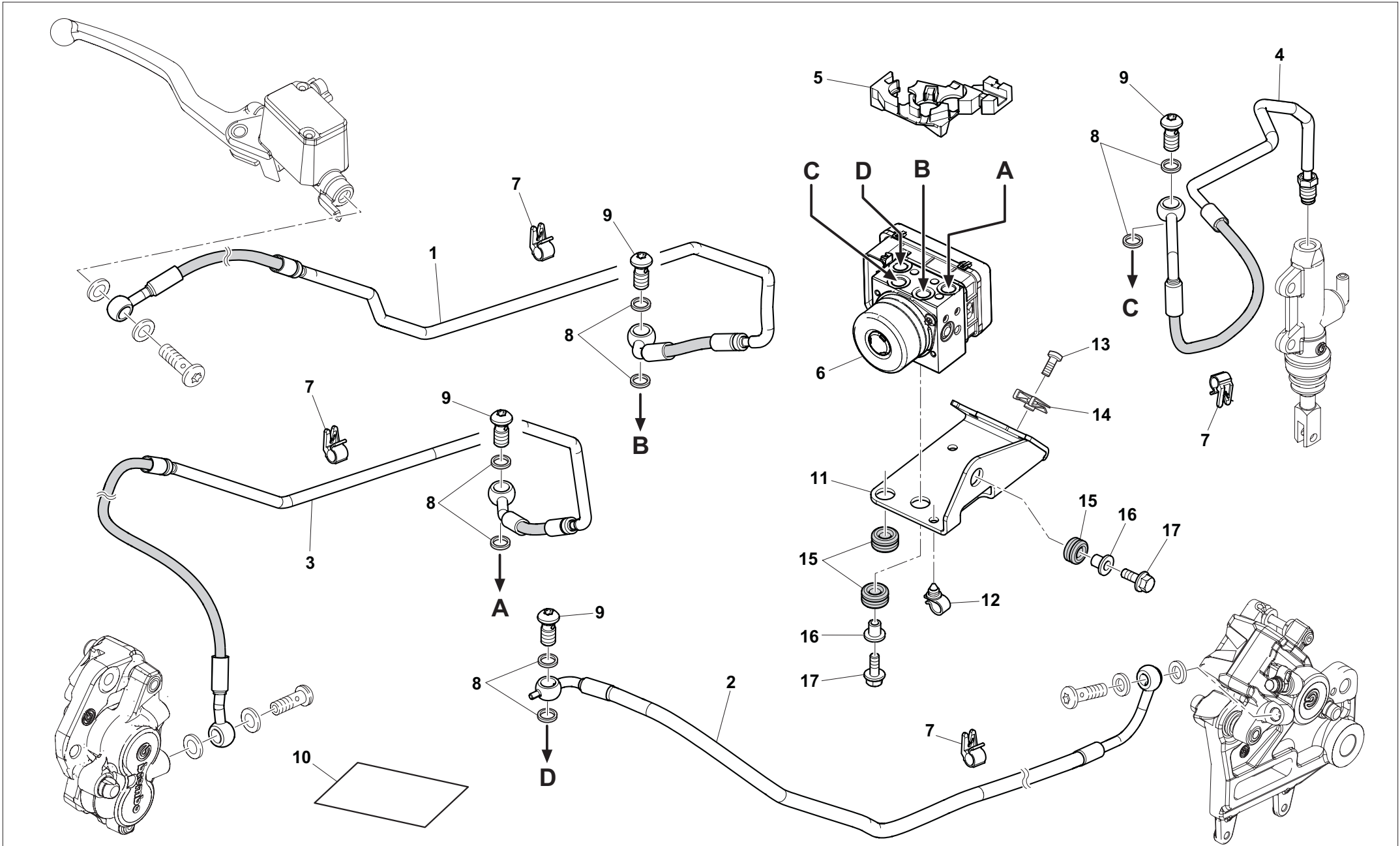

TR 650 Terra/2013
TR 650 Strada/2013

TAVOLA - DRAWING
TABLE - BILD - TABLA

46

IMPIANTO ABS - ABS SYSTEM
INSTALLATION ABS - SYSTEM ABS
EQUIPO ABS



Note Notes Notes Marke Notas	Pos. No. N. Index Pos.	N. Cod. Code No. Nr. Code Code Nr N. Cod.	Q.tà Q.ty Q.te M.ge C.ad	DENOMINAZIONE	NAME	DESIGNATION	BESHREIBUNG	DENOMINACION
	1	8538783	1	Tubo freno anteriore pompa-HCU	Front brake tube pump-HCU	Tuyau de frein avant pompe-HCU	Rohr Vorderradbremse pumpe-HCU	Tubo freno delantero bomba-HCU
	2	8538784	1	Tubo freno posteriore pinza-HCU	Rear brake tube calliper-HCU	Tuyau de frein arrière etrier-HCU	Rohr Hinterradbremse Bremssattel-HCU	Tubo freno trasero pinza-HCU
Strada	3	8539417	1	Tubo freno anteriore pinza-HCU	Front brake tube calliper-HCU	Tuyau de frein avant etrier-HCU	Rohr Vorderradbremse Bremssattel-HCU	Tubo freno delantero pinza-HCU
Terra	3	8538782	1	Tubo freno anteriore pinza-HCU	Front brake tube calliper-HCU	Tuyau de frein avant etrier-HCU	Rohr Vorderradbremse Bremssattel-HCU	Tubo freno delantero pinza-HCU
	4	8538785	1	Tubo freno posteriore pompa-HCU	Rear brake tube pump-HCU	Tuyau de frein arrière pompe-HCU	Rohr Hinterradbremse pumpe-HCU	Tubo freno trasero bomba-HCU
	5	8538786	1	Piastra	Plate	Plaque	Platte	Placa
	6	8533721	1	Centralina elettronica	Electronic control unit	Boîtier électronique	Steuerelektronik	Centralita electrónica
	7	1362825	8	Morsetto	Clamp	Etrier	Klemme	Borne
	8	8539140	8	Rosetta	Washer	Rondelle	Unterlegscheibe	Arandela
M10x1	9	7667316	4	Vite forata	Screw	Vis	Schraube	Boca
	10	800087072	1	Adesivo	Sticker	Adhésif	Aufkleber	Adhesivo
	11	8538817	1	Supporto centralina	ECU support	Support centrale	Halterung Steuergerät	Soporte centralita
	12	8539161	1	Clip di fissaggio	Fastening clip	Clip de fixation	Clip	Clip fijación
M6x45	13	6973219	2	Vite	Screw	Vis	Schraube	Tornillo
	14	U00046893	2	Dado a graffetta	Clip nut	Ecrou à agrafe	Sicherungsmutter	Tuerca de clip
	15	1233200	3	Antivibrante	Silent-block	Antivibration	Dämpfer	Anti-vibrador
	16	8000H1735	2	Bussola	Bushing	Douille	Buchse	Casquillo
	17	7653180	2	Vite	Screw	Vis	Schraube	Tornillo

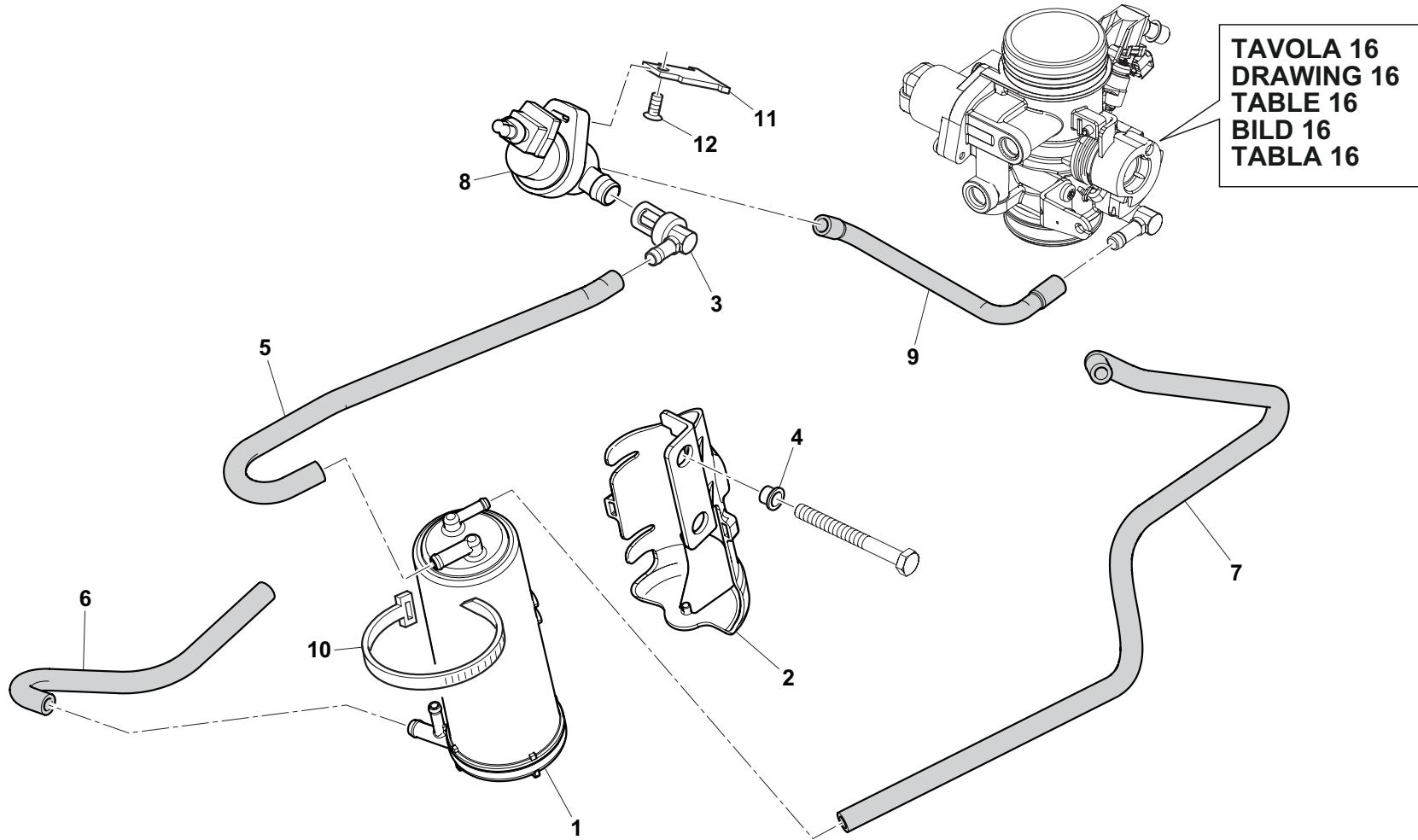

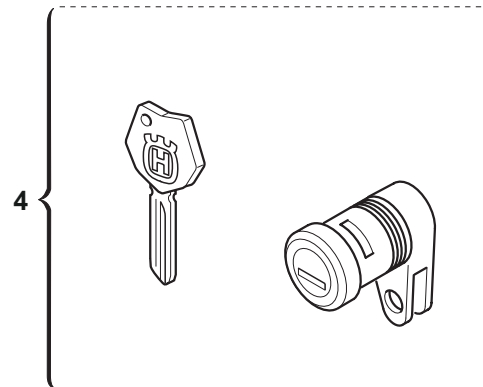
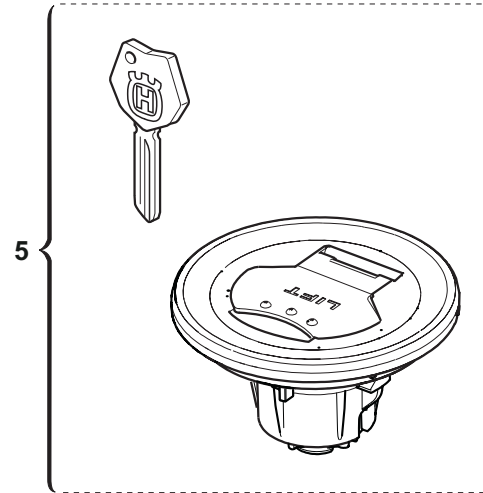
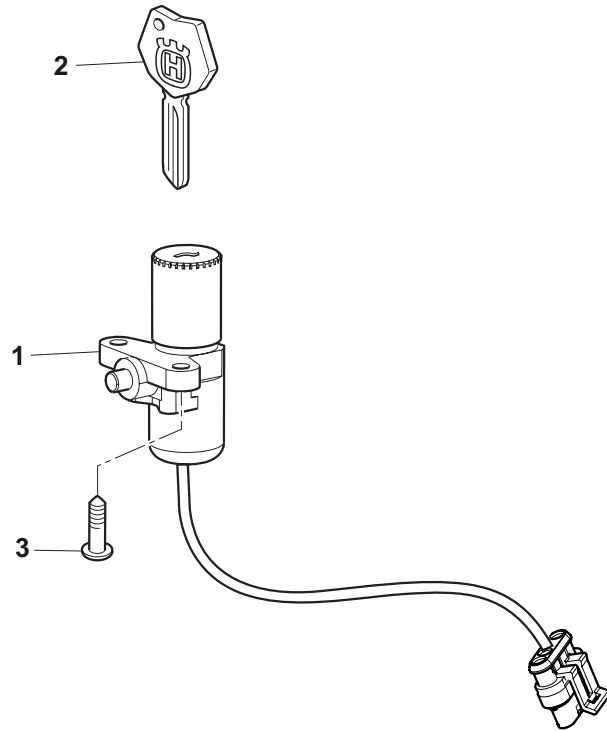

TR 650 Terra/2013
TR 650 Strada/2013

TAVOLA - DRAWING
 TABLE - BILD - TABLA

48

KIT SERRATURE - LOCK KIT
KIT SERRURE - SATZ SCHLOSSER
KIT CERRADURAS



Note Notes Notes Marke Notas	Pos. No. N. Index Pos.	N. Cod. Code No. Nr. Code Code Nr N. Cod.	Q.tà Q.ty Q.te M.ge C.ad	DENOMINAZIONE	NAME	DESIGNATION	BESHREIBUNG	DENOMINACION
	1	CODED PART	1	Commutatore compl.	Complete switch	Commutateur compl.	Umschalter kompl.	Conmutador compl.
	2	CODED PART	1	Chiave con transponder	Key with transponder	Clé avec transpondeur	Schlüssel mit Transponder	Llave con transpondedor
M8x20	3	8539477	2	Vite	Screw	Vis	Schraube	Tornillo
	4	8539231	1	Serratura sella con chiave	Saddle lock with key	Serrure selle avec clé	Sitzbankschloss mit Schlüssel	Cerradura asiento con llave
	5	8000H7045	1	Tappo con chiave	Plug with key	Bouchon avec clé	Deckel mit Schlüssel	Tapón con llave

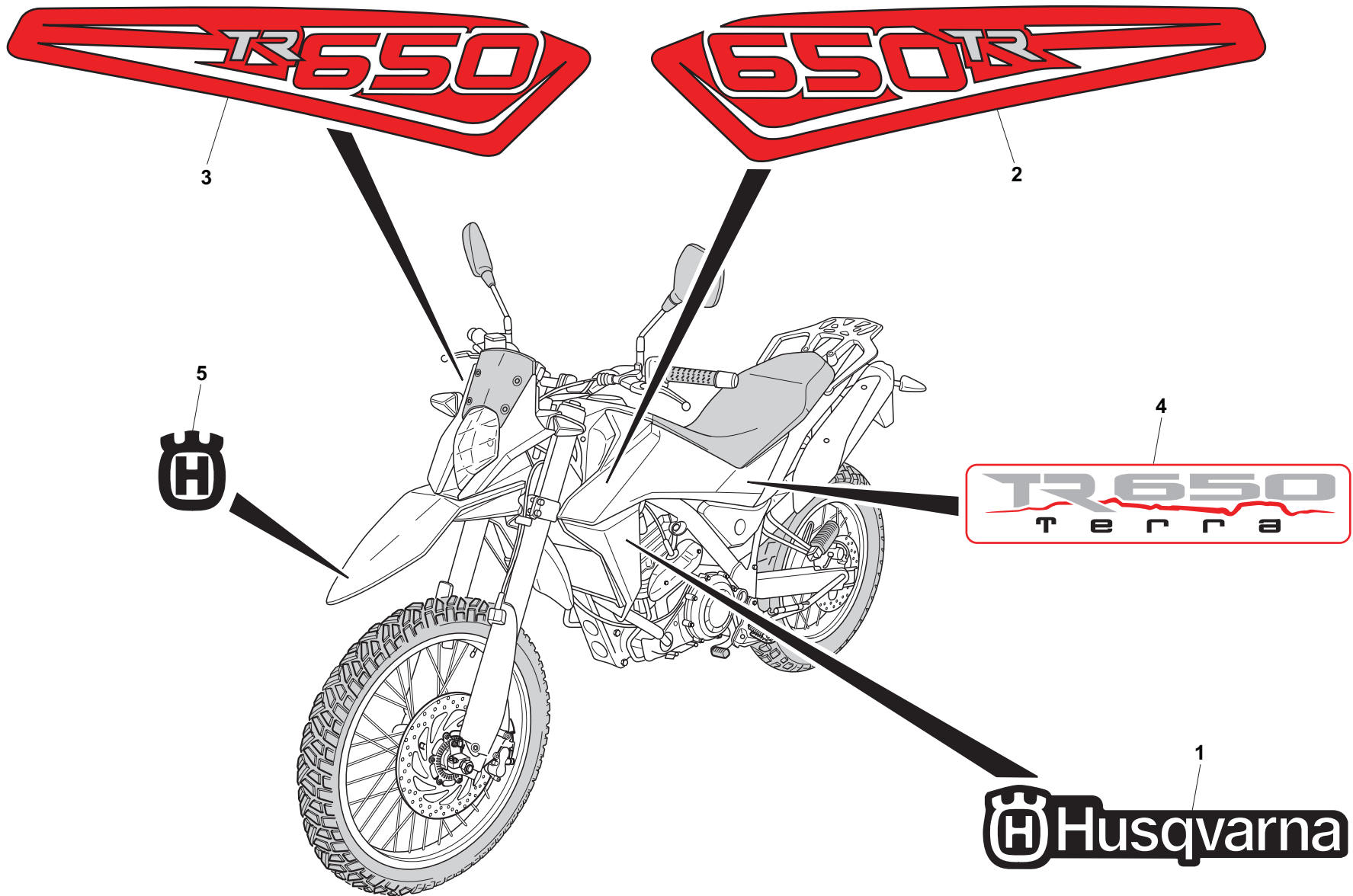

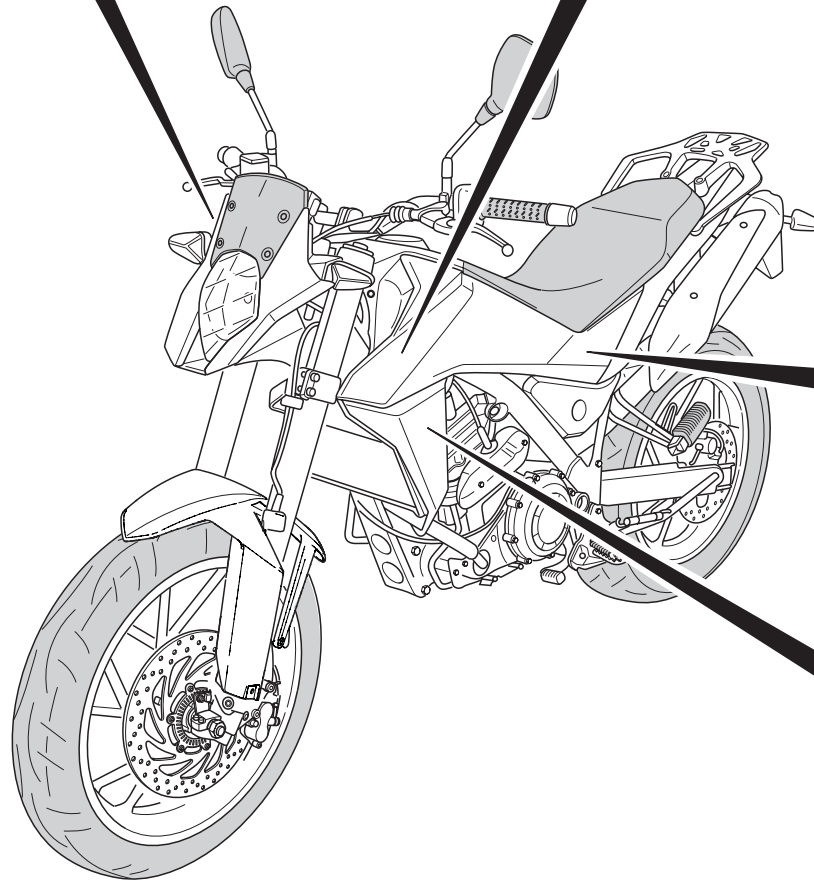

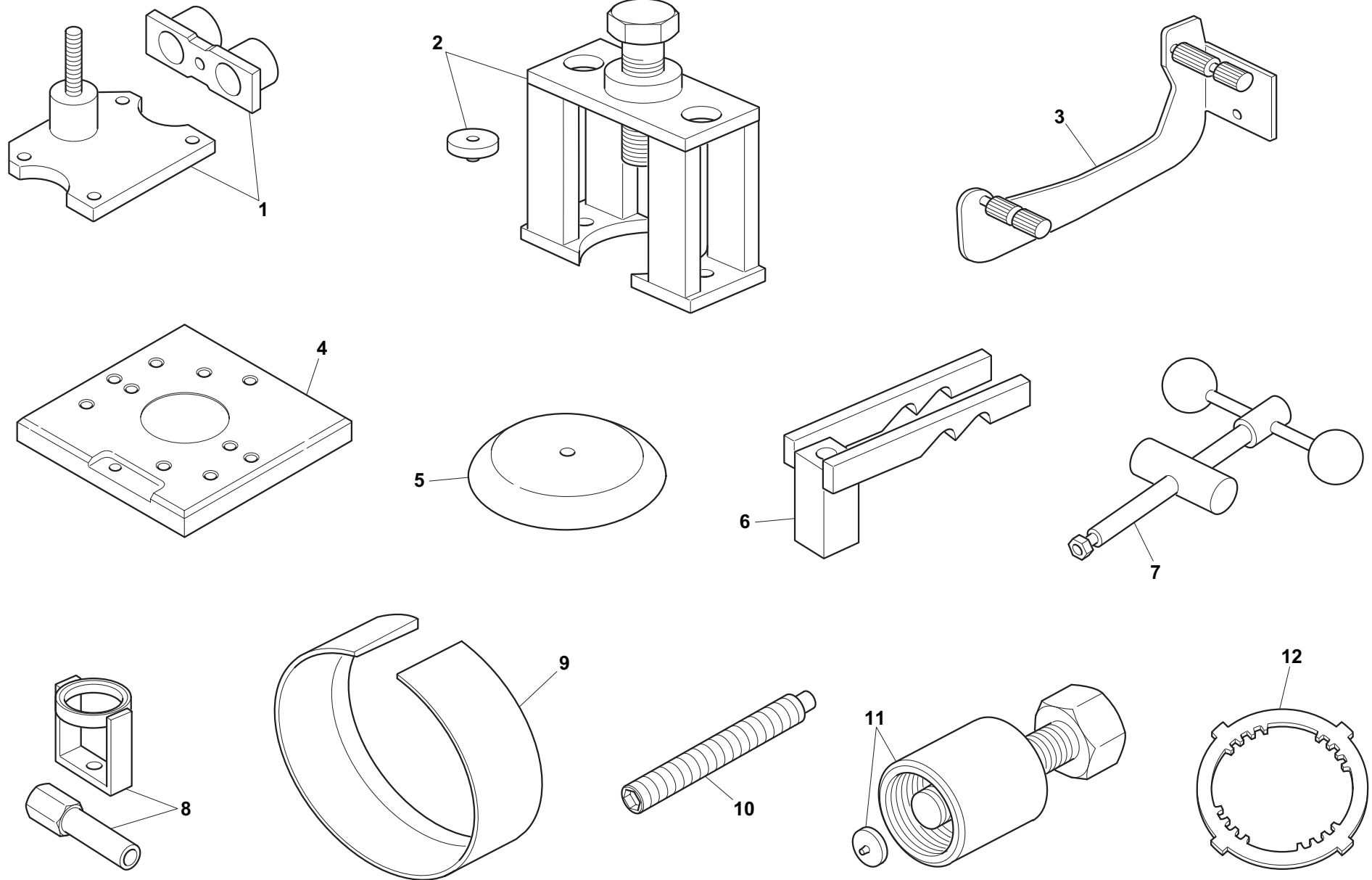

TR 650 Terra/2013
TR 650 Strada/2013

TAVOLA - DRAWING
 TABLE - BILD - TABLA

51

ATTREZZI OFFICINA - WORKSHOP TOOLS
EQUIPEMENT DES ATELIERS - SPEZIALWERKZEUG
HERRAMIENTAS DE TALLER



Note Notes Marke Notas	Pos. No. Index Pos.	N. Cod. Code No. Nr. Code Code Nr N. Cod.	Q.tà Q.ty M.ge C.ad	DENOMINAZIONE	NAME	DESIGNATION	BESHREIBUNG	DENOMINACION
	1	0401411	1	Attrezzo montaggio smontaggio valvole	Valve assembly/removal tool	Outil montage dépose soupapes	Werkzeug f. Einbau / Ausbau Ventile	Herramienta montaje desmontaje válvulas
	2	0401595	1	Estrattore	Puller	Extracteur	Abzieher	Extractor
	3	0401428	1	Sostegno motore	Engine support	Support moteur	Stützrahmen	Sujeción motor
	4	8000H5015	1	Piastra supporto smontaggio valvole	Valve removal support plate	Plaque de support pour dépose soupapes	Halterungsplatte f. Ventilausbau	Placa soporte para desmontaje válvulas
	5	8000H5042	1	Inserto smontaggio valvole	Valve removal insert	Insert pour dépose soupapes	Halterungs f. Ventilausbau	Insert desmontaje válvulas
	6	0401578	1	Supporto smontaggio valvole	Valve removal support	Support dépose soupapes	Ausbaunterlage Ventile	Soporte desmontaje válvulas
	7	8000H5016	1	Spingimolle	Pressure plate	Presse-ressorts	Federdruckscheibe	Plato de presión muelles
	8	0401580	1	Attrezzo alloggiamento piattello	Plate driving tool	Outil fixation plateau	Eintreibwerkzeug Federteller	Herramienta instalación plato
	9	0401599	1	Bussola montaggio pistone	Piston installing bushing	Douille	Buchse	Casquillo
	10	8000H5009	1	Vite bloccaggio albero motore al PMS	Crankshaft locking screw at TDC	Vis de blocage vilebrequin au P.M.H.	Befestigungsschraube Kurbelwelle am OT	Tornillo bloqueo cigüeñal en el PMS
M38x1,5	11	0401710	1	Estrattore	Puller	Extracteur	Abzieher	Extractor
	12	0435798	1	Disco bloccaggio campana frizione	Clutch housing locking disc	Disque de blocage cage embrayage	Kupplungskorb Scheibe	Disco bloqueo campana embrague